

WATER

DOWNTOWN LITTLE ROCK MASTER PLAN

June 2024



TABLE OF CONTENTS

EXECUTIVE
SUMMARY

INTRODUCTION

DISCOVERY

VISION

IMPLEMENTATION

APPENDIX

MASTER PLAN Recognition

Thank you to all who contributed their time, energy, and passion to creating this vision for the future of Downtown Little Rock. This master plan could not have been created without the input of the community and the following groups and individuals. This project was supported in whole or in part by federal award number SLT-0888 awarded to the City of Little Rock by the U.S. Department of Treasury.

Project Lead

Sasaki: Joshua Brooks, Fred Merrill, Susannah Drake, Daniel Church, Emilie Forbes, Alex Hill, Caroline Lindquist, Shih-Hao Liao, Alice Calmon, Armin Akhavan, Sydney Bittinger, Taylor Tidwell, Timothy Gale, Surbhi Agrawal, Robert Guertin, Aeshna Prasad, Fan Yang

Subconsultants

LOCAL TEAM:

AMR Architects: Kate East, James Sullivan, Heather Davis, Kyle Heflin
Crystal C. Mercer Watson

Walker Consultants: Jim Corbett, Ben Weber

SB Friedman: Ranadip Bose, Elena Caminer, Emma Bonanno

Master Plan Executive Steering Committee

Mayor Frank Scott	Mayor of Little Rock
Director Antwan Phillips	City Board of Directors At-Large
Director Virgil Miller	City Board of Directors Ward 1
Director Dean Kumpuris	City Board of Directors At-Large
Jamie Collins	City of Little Rock Planning + Development Director
Gabe Holmstrom	Executive Director of Downtown Little Rock Partnership
Justin Avery	CEO of Rock Region Metro
John Honeywell	City of Little Rock Public Works Director
Leland Couch	City of Little Rock Parks and Recreation Director
Kevin Howard	City of Little Rock Housing Director
Carol Worley	Past President of Downtown Little Rock Partnership
Sarah Thomas	President of the Downtown Neighborhood Association
Casey Covington	Director of Metroplan
Gina Gemberling	President & CEO of Little Rock Convention and Visitors Bureau
Jay Chessir	President & CEO of Little Rock Regional Chamber of Commerce
Michael Harry	Arkansas State Capitol -- Secretary of State's Office
David Sargent	President of Downtown Little Rock Partnership

Master Plan Stakeholder Advisory Committee

Patricia Blick, Brian Minyard, Nikki Crane, Jimmy Moses, Hank Kelley, LaTonya Hayes, Chris East, Bobby Matthews, Representative Denise Ennett, Evelyn Shepherd, Gillian Gullett, Mason Ellis, Mike Orndorff, Buckley O'Mell, Quantia Fletcher, Colin Crawford, Jamie Wiggins, Nate Coulter, Jay Barth, Ronnie Jackson, Shawn Govind, Dazmin Murry, Jonathan Nunn, German Jimenez, Sheila Miles, Ruby Jean Jefferies, Stephanie Jackson

Master Plan Focus Groups

CULTURE, INSTITUTIONS, AND URBAN ACTIVATIONS

Gina Gemberling, Brent Birch, David Hutchinson, LaTonya Hayes, Alex Thomas, Quantia Fletcher, Kelley Bass, Jay Chessir, Patrick Ralston, Senator Clarke Tucker, Wena Supernaw, Rev. Ryan D. Davis, Jay Barth, Rev. Shantell Hinton-Hill, Stacey McAdoo, Daniel Bryant, Benito Lubazibwa, Mariah Hatta, Victoria Ramirez, Osiris Bolly, Dan Kovach, Don Dugan, Fidel Samour, Amy Counce, Chris New, Jamie Wiggins, Colin Crawford, Michael Harry, Stephanie Wade, Andy Davis, Dazmin Murry, Wil Trice, Justin Acri

DEVELOPMENT, DENSITY, AND URBAN DESIGN

Jimmy Moses, Hank Kelley, Kevin Howard, Brian Minyard, Patricia Blick, Mike Orndorff, Buckley O'Mell, Merritt Dake, Adam Fogleman, Amber Banks, Carol Worley, Chris East, Dean Kumpuris, Virgil Miller, David Sargent, Representative Denise Ennett, Sarah Thomas, Joshua Price, Kate Askew, Antwan Phillips, William Callahan, Ron Witherspoon, Jeff Hathaway, Bryan Hosto, Jonathan Nunn, Jessica Flake Dearnley, Jill Judy, Warren Simpson, Ronnie Jackson, Bobby Matthews, Evelyn Shepherd, Shelia Miles, Ruby Jean Jefferies, German Jimenez, Shawn Govind, Jim Jackson, Allen Engstrom, Hannah Ratzlaff

TRANSPORTATION, PARKING, AND MOBILITY

Justin Avery, John Honeywell, Gillian Gullett, Casey Covington, Mason Ellis, Rachel Cotner, Ellen Fennell, Jeremy Gosdin, Dave Roberts, Nat Banihatti, Kim Sanders, Mike Sprague, Jordan Mays, Tab Townsell, Colleen Bailey, John Landosky

OPEN SPACE AND PUBLIC REALM

Nikki Crane, Leland Couch, Jordan Thomas, Kevin Pranoto, Aaron Reddin, Heath Helton, Brett Budolfson, Lou Tobian, Nate Coulter, Sam Ellis, Mandy Davis, Terry Jones, Christian Woods, Tig Kalisha, Miguel Lopez, Arlton Lowery, Sharon Priest, Elizabeth Michael, Diana Long, Wesley Prewett, Ed Sergeant, Katie Rutledge

City Board of Directors

Mayor Frank Scott Jr.

Ward 1 Director Virgil Miller Jr.

Ward 2 Director Ken Richardson

Ward 3 Director Vice-Mayor Kathy Webb

Ward 4 Director Capi Peck

Ward 5 Director Lance Hines

Ward 6 Director Andrea Hogan Lewis

Ward 7 Director B.J. (Brenda) Wyrick

Position 8 Director Dr. Dean Kumpuris

Position 9 Director Antwan Phillips

Position 10 Director Joan Adcock

Other Special Thanks

City of Little Rock

Downtown Little Rock Partnership

Mosaic Templars Cultural Center

Little Rock Convention and Visitors Bureau

Little Rock Central High School

Dunbar Public Library

Dunbar Magnet Middle School

Central Arkansas Library System

William J Clinton Presidential Center

AC Hotel Downtown Little Rock

MASTER PLAN

Letters



Dear Little Rock,

Letter from the Mayor of Little Rock in Progress

Frank Scott Jr.

Mayor - City of Little Rock, Arkansas



Dear Little Rock,

I am thrilled to present to you our city's first comprehensive Downtown Little Rock Master Plan, a visionary roadmap that promises to redefine the heart of our city. This plan is not just a document; it's a step-by-step guide to a vibrant, prosperous, and connected future for downtown Little Rock.

Imagine streets pulsing with life day and night, connected by trails and streetscapes designed to make people feel comfortable and safe. Picture a place where families, workers, and visitors come together to enjoy a tapestry of neighborhoods, each with its own unique charm and character. This is the downtown we can create together!

Our plan lays out bold strategies to double our downtown population by 2035, connect our cultural assets, and transform our transportation networks. It calls on us to embrace the Arkansas River, an incredible natural resource our city is not using to its fullest potential. It's about making Downtown Little Rock a destination that is not only safe and welcoming but also dynamic and inclusive.

But to bring this vision to life, we need you. Your energy, your passion, and your voice are crucial to shaping the future of our Downtown. Join us in this exciting journey to make Downtown Little Rock the hub of urban life and outdoor recreation for all of Arkansas.

Let's roll up our sleeves and turn this plan into reality. Together, we can rebuild and reimagine the urban fabric for our city center, one that reflects the vibrant spirit of Little Rock.

With anticipation and excitement,

Gabe Holmstrom

Executive Director - Downtown Little Rock Partnership

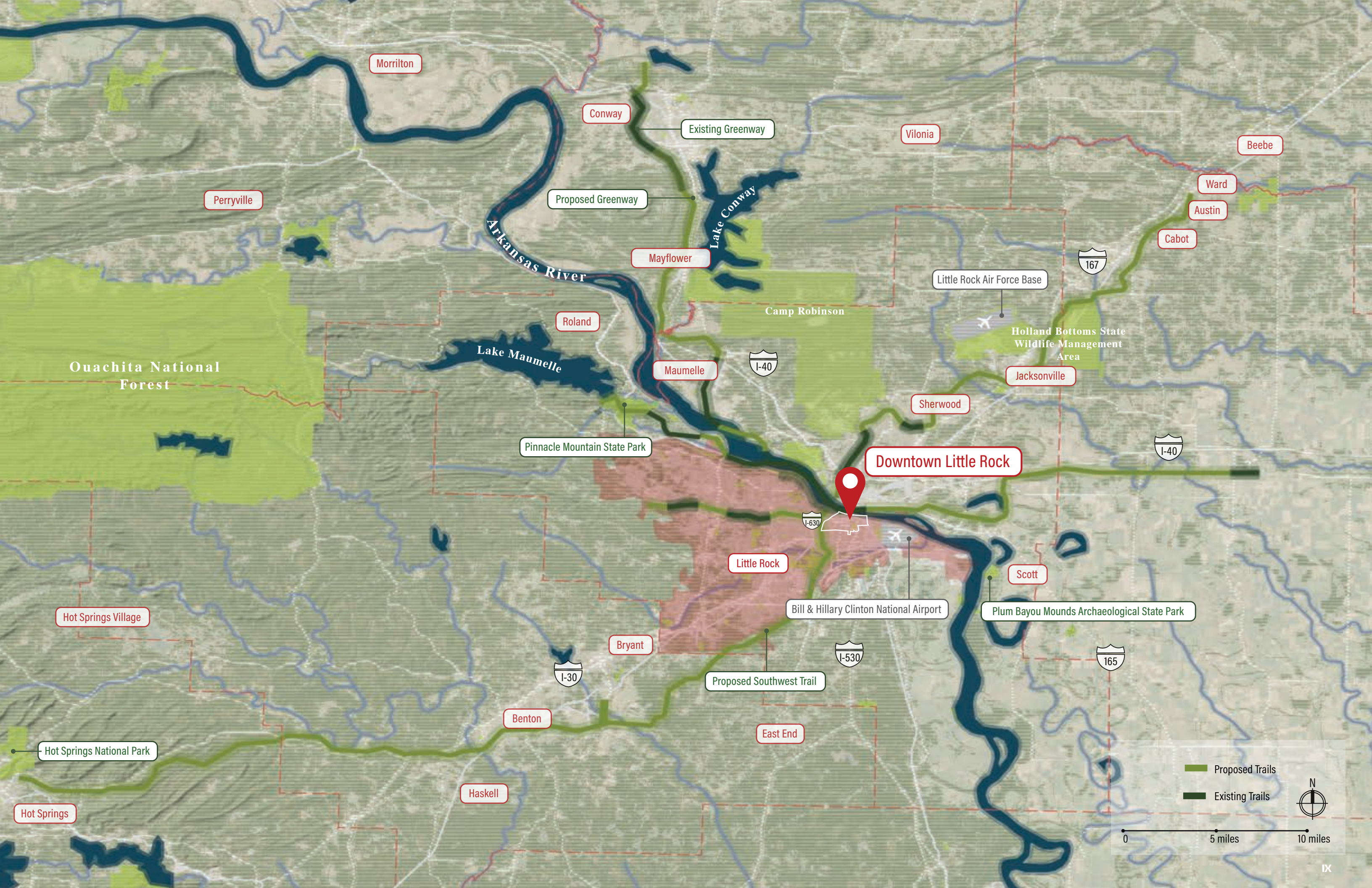

Proposed Trails
Existing Trails

0 5 miles 10 miles



DOWNTOWN LITTLE ROCK



Downtown Little Rock is the historic heart of Little Rock. From its time as Quapaw land, to its founding as a frontier trading settlement, to its establishment as the center of Arkansas' government, it has been defined by its unique position in the State and along the Arkansas River.

Downtown Little Rock is more than the vibrant nightlife of the River Market, the office towers of the Financial Quarter, or the State Capitol. It is a collection of distinct districts and neighborhoods, a mosaic of cultures and

histories, and home to numerous historic monuments and buildings. The destination of Downtown Little Rock is just that, a destination - for all of greater Little Rock, Central Arkansas, and guests and visitors alike.

The Downtown Little Rock Master Plan defined "Downtown" as the 2.5-square mile area bounded by the Arkansas River to the north, Bond Street to the east, E 9th Street and 14th Street to the south, and the Union Pacific Railroad to the west.

THE HEART Of Central Arkansas

Downtown Little Rock has a robust history that is important to both Arkansas and the nation as a whole. Prior to White settlement, the area now known as Little Rock was largely Quapaw land, although the Caddo and Osage nations were also present. Downtown Little Rock, founded as a trading post in 1812, is one of the oldest continuously inhabited White settlements in Arkansas and thus contains some of the State's most important historical and cultural sites. Understanding the many histories that have occurred in Downtown Little Rock is critical in shaping a plan that can shape Downtown into the future.



CROSSROADS OF TRANSIT & TRAFFIC

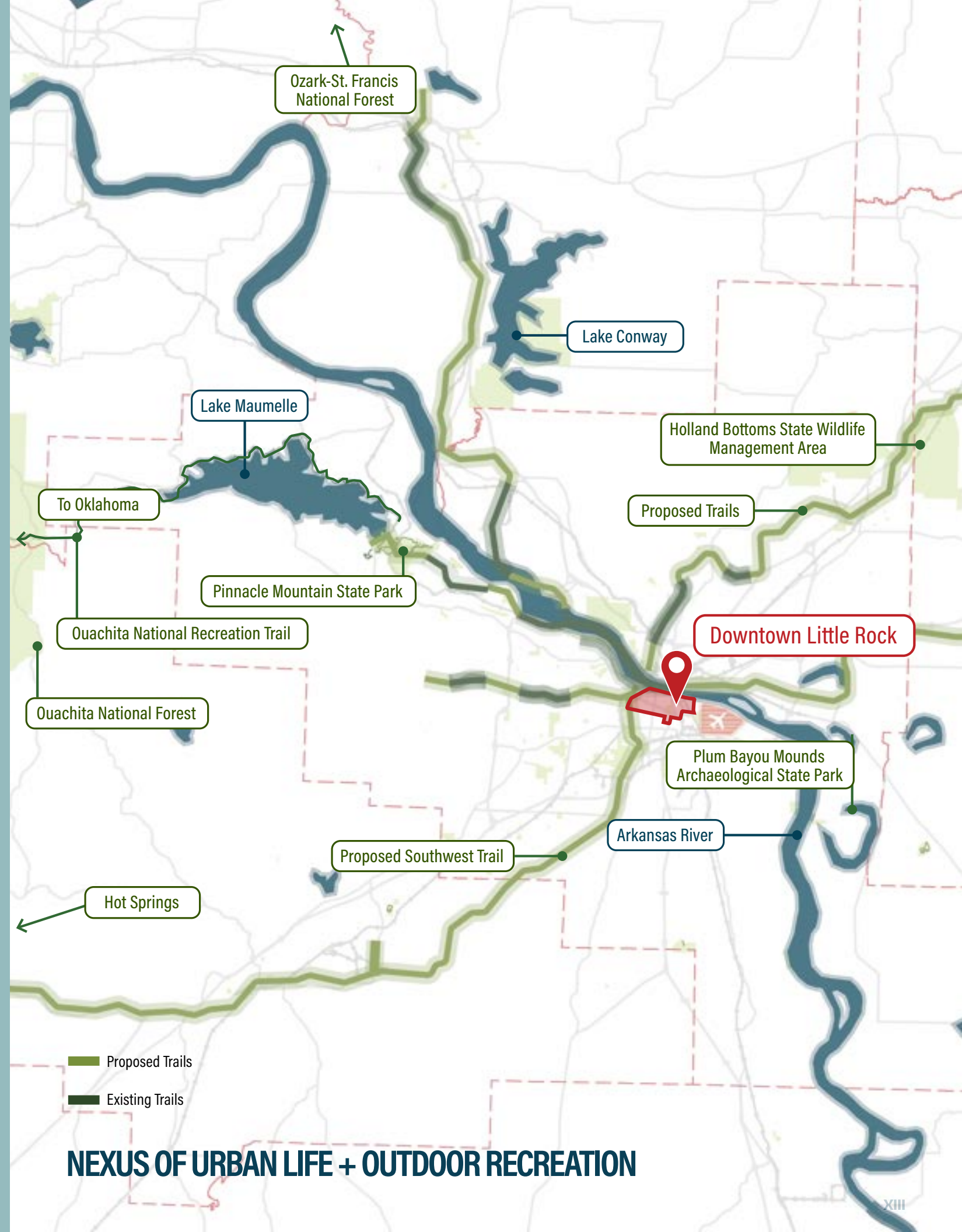
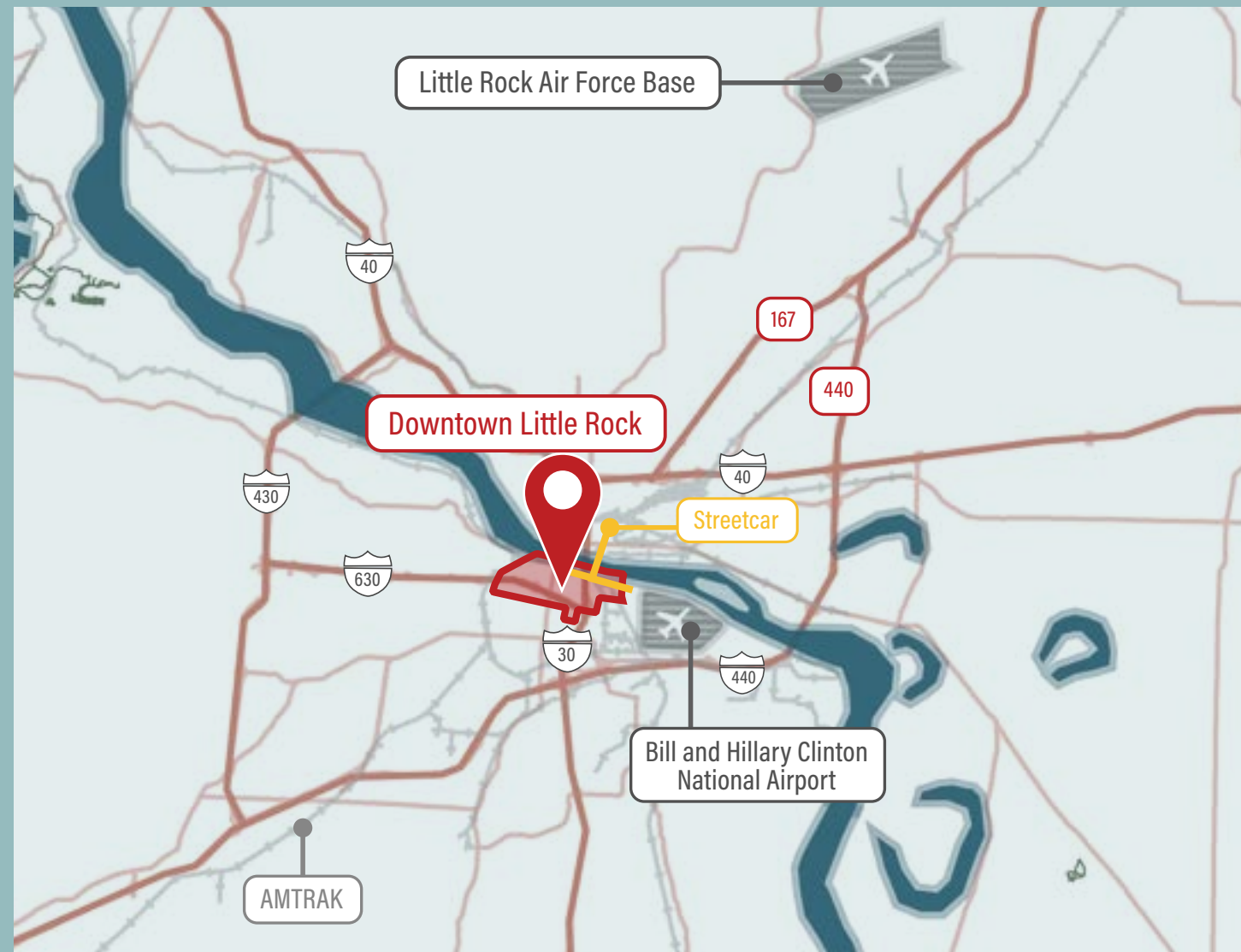

NEXUS OF URBAN LIFE + OUTDOOR RECREATION

BY THE NUMBERS

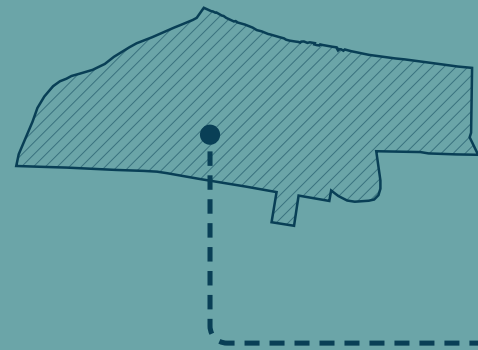

2.5
sq. miles
Size of Study Area



60.4
acres
Area of city-managed public parks in Downtown

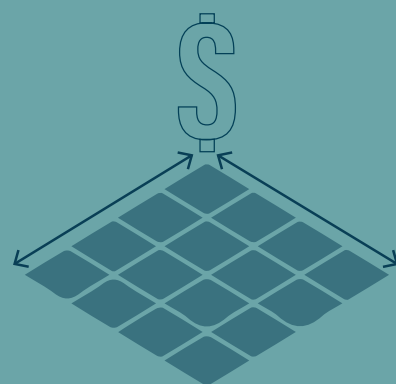

\$529
Million
Assessed Value per square mile

DEMOGRAPHICS

■ Downtown
■ City of Little Rock

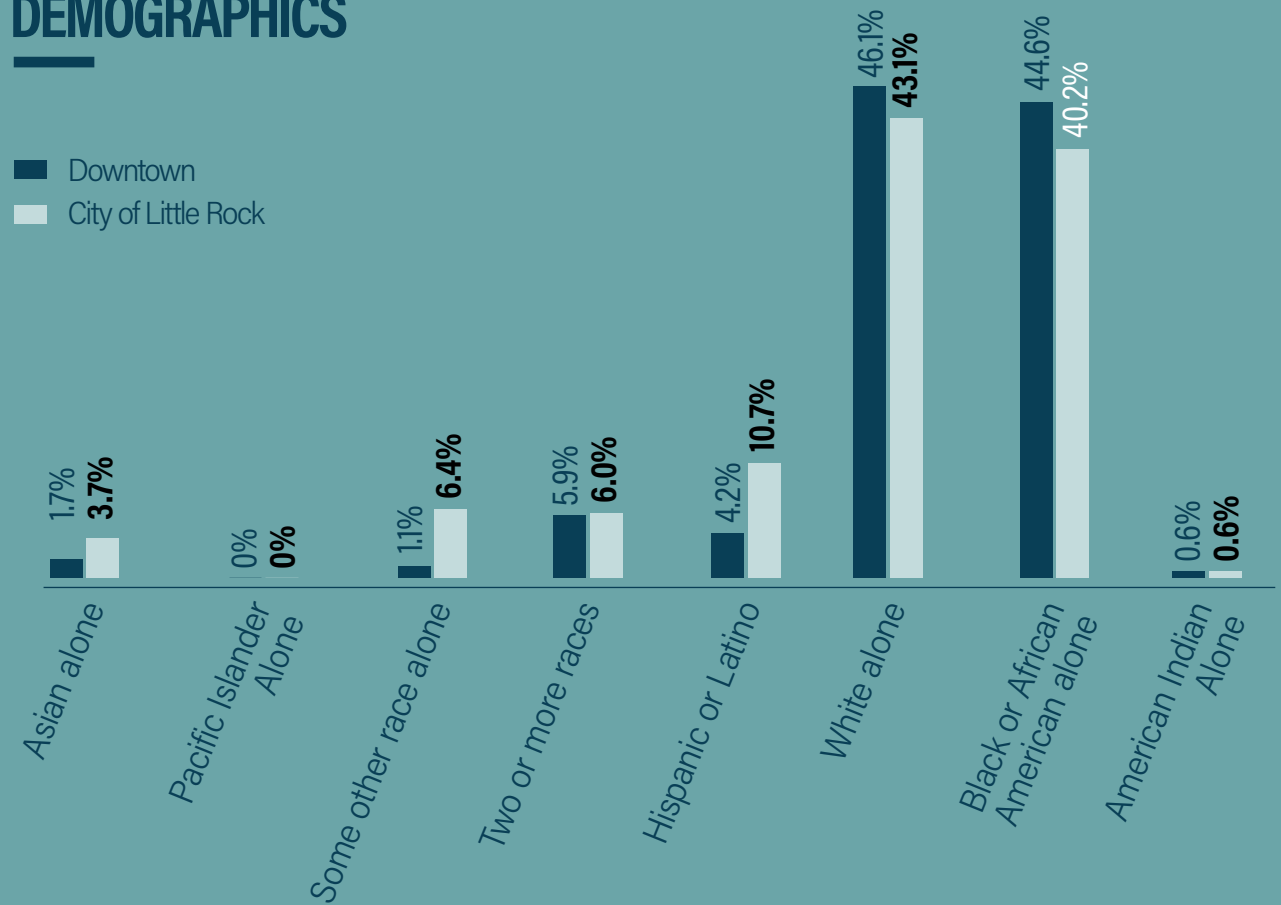

4,395
Number of Residents Living Downtown



54%
BIPOC Residents



+/- 42,900
Number of Employees Working Downtown



-5%
Job Growth in Downtown 2010-2018

Source: SB Friedman Development Advisors, LLC (See Appendix for More Details)

1

**Executive
Summary**

MASTER PLAN

Envisioning a Plan

The Downtown Little Rock Master Plan is the first ever comprehensive master plan for Downtown Little Rock. The goal is to create a strategic vision for growth and development to guide a better future for downtown and its users. The vision laid out in this master plan will serve as a road map for future decision making by the City of Little Rock, other agencies, the development community, neighborhoods, and individuals. This vision includes enhanced multimodal connectivity within the district and to others areas, a safe and vibrant public realm, and improved public open spaces, all with the goal of increasing quality of life for residents, workers and visitors.



MASTER PLAN

The Challenge

Little Rock is at a crossroads. For the past 25 years, its downtown has grown and evolved, bringing new housing, retail, entertainment, and cultural attractions to the district. And while revitalization continued after the 2008 Great Recession, it has done so at a slower pace than its peers. Without a plan for changing that in the future, it is a very real possibility that Little Rock and all of Central Arkansas will slide in a negative direction.

Like many downtowns, Downtown Little Rock aims to redefine itself in a post-COVID world. Over the last decade, Downtown has seen marginal job growth when compared to the rest of Central Arkansas and has seen employers leave for suburban locations. Concerns about safety and homelessness, a lack of quality of life amenities, and a general sense of lifelessness are often cited as to why employers relocated.

Most importantly, changing employment patterns precipitated by COVID have amplified existing perceptions the broader public and region has about the district. This change in perception has had a negative impact on retail and restaurants and has led employers to leave the core. Active districts are less busy, weekends are less vibrant, and concerns about safety and homelessness are magnified by the general lack of people present.

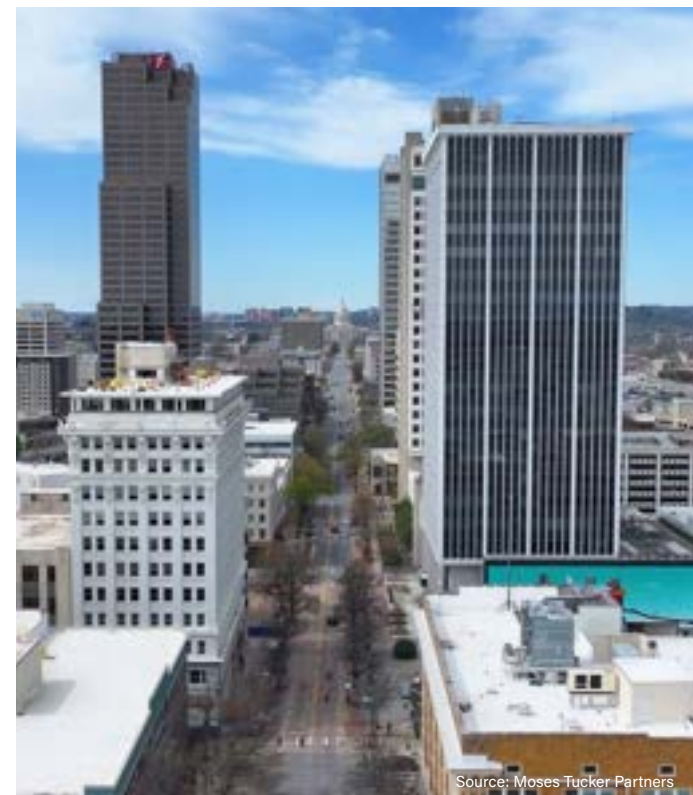

Source: Moses Tucker Partners



The Downtown Little Rock Master Plan is a roadmap to change these perceptions and to provide a strong guide for change. Changing the dynamic in Downtown will have positive ripple effects across all of Central Arkansas. Although the Master Plan lays out 44 strategies across a variety of topics, a few key items are essential for plan guidance:

- 1** Downtown Little Rock has an **amazing geographic setting** along the Arkansas River and is **THE center of culture** for all of Arkansas. These are huge strengths that cannot be replicated.
- 2** Downtown residential density is up to four times less than what it should be. **A key goal in this Master Plan is to double Downtown's residential population by 2035.**
- 3** There are **large amounts of available, underutilized land**, mostly surface parking lots, which are **prime sites for new infill development.**
- 4** The **civic infrastructure in Downtown**, including City Hall, the Downtown Partnership, other agencies, and private development, **needs to coalesce around the Downtown Master Plan.**

Key Takeaways

In order to identify opportunities for enhancements in the future, it was first important to evaluate existing conditions. Through geospatial analysis, conversations with stakeholders, and a robust market scan, key takeaways emerged around economic development, parks and open space, mobility, and culture and institutions. The most critical takeaways are listed below.



There is a lack of institutionalized economic development tools Downtown.



Residential population density is far lower than peer downtowns and needs to increase.



The Downtown Partnership's role is critical and should be enhanced and reimagined.



The Arkansas River is a tremendous open space asset that is underutilized.

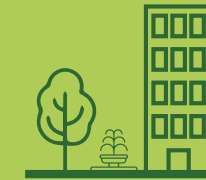

The removal of the I-30 off-ramps in the River Market area are a once-in-a-lifetime opportunity.



The proposed network of trails will make Downtown an epicenter for multi-mobility and outdoor recreation.



Infrastructure improvements are needed on Downtown streets.



Downtown is an epicenter of history and culture that has huge potential for placemaking and tourism.



Events and programming are popular and should be better promoted and expanded.

THE VISION

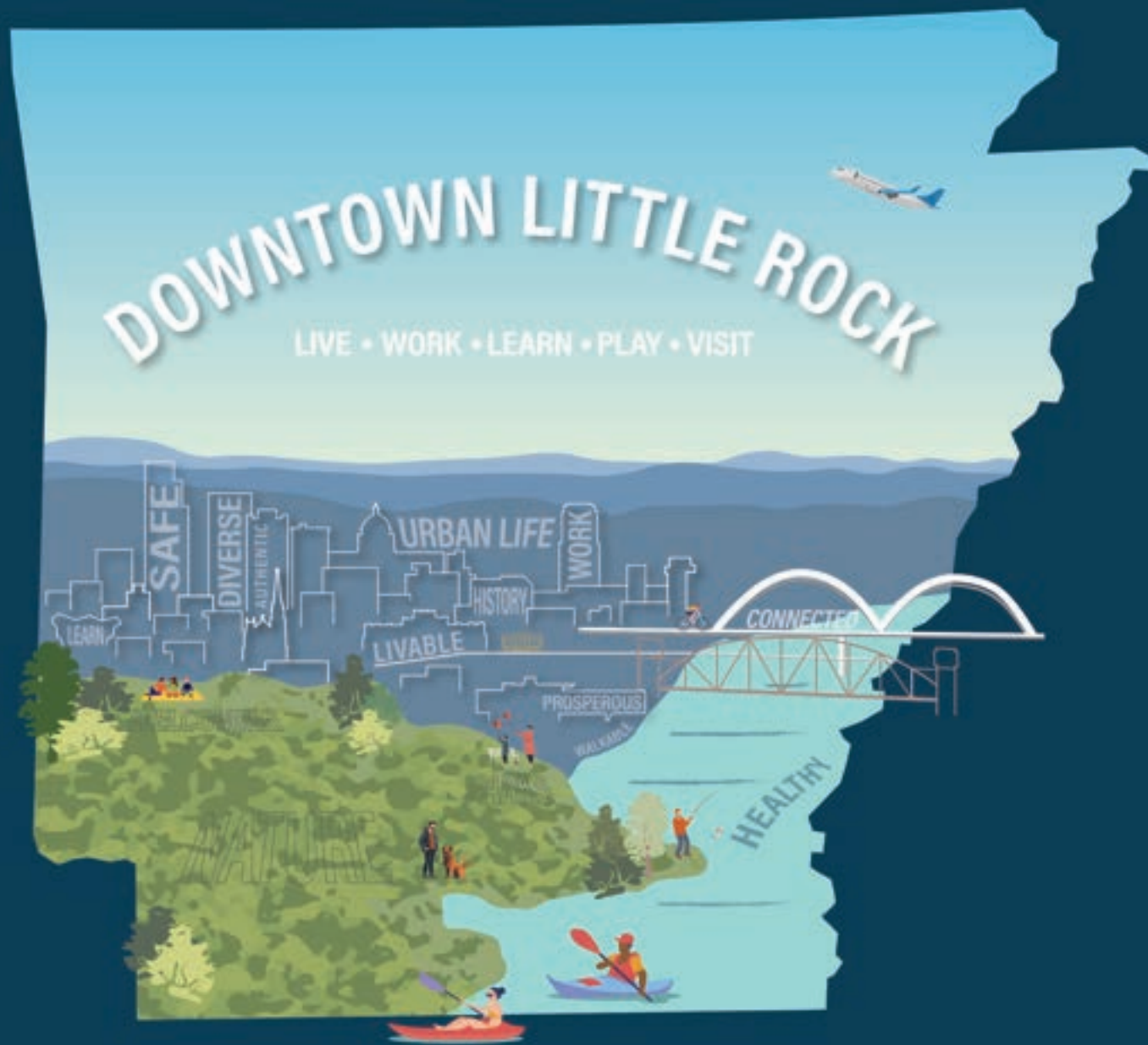

Downtown Little Rock is the heart of urban life available for all of Arkansas – a safe and vibrant hub for history, culture, activity, and recreation along the banks of the Arkansas River.

Downtown is a constant pulse of activity - a highly-desired place to raise a family, work, and socialize because it is a diverse and inclusive collection of neighborhoods and people.

THE VALUES

During the Discovery and Goals phase of the planning process, the Executive Steering Committee and Stakeholder Advisory Committee established key values derived from community input. These values were then used as evaluation tools internally and with the public when evaluating the Big Ideas and subsequent strategies. The following are the six key values that emerged from the process.

- Welcoming & Safe**: Icon showing two people standing in front of a building with a location pin.
- Livable & People-Focused**: Icon showing a city street scene with buildings and people.
- Authentic & Diverse**: Icon showing a map of Arkansas with various symbols representing different aspects of the community.
- Sustainable & Resilient**: Icon showing a river, trees, a sun, and a building.
- Vibrant & Prosperous**: Icon showing two people with musical notes and a city skyline.
- Dynamic & Connected**: Icon showing a person on a bicycle, a location pin, and arrows pointing in various directions.

PROCESS

Schedule & Team

The Downtown Master Plan, funded by the City of Little Rock and conducted in collaboration with the Downtown Little Rock Partnership, was a nine-month long planning effort that established strategic goals and actions around topics such as development, urban design, streets, mobility, and parks and open space. The Downtown Master Plan was achieved through a process of co-creation with the community. The planning team, the City, and the Downtown Partnership listened to thousands of stakeholders and

citizens in order to understand their vision and aspirations for their urban heart.

The iterative planning process was composed of four key phases that were each continually fed by community engagement. These phases included Discovery and Goal Setting, District Framework Vision, Implementation Planning, and Draft Plan and Adoption.

WHAT WOULD MAKE YOU WANT TO LIVE DOWNTOWN?
 "The positivity around Downtown Little Rock...and overall how others treat each other."
 - Dunbar Middle School Student

Schedule

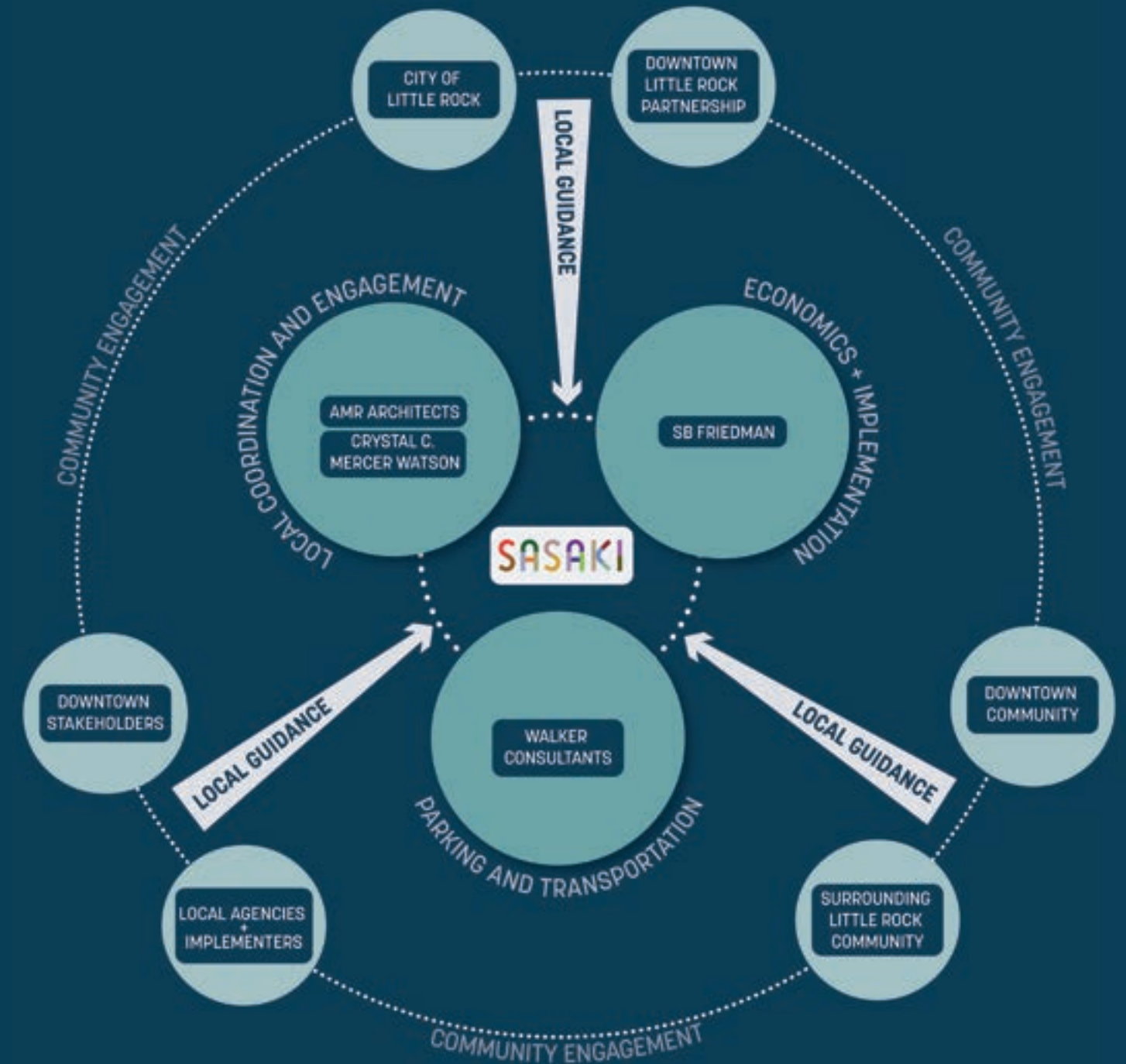
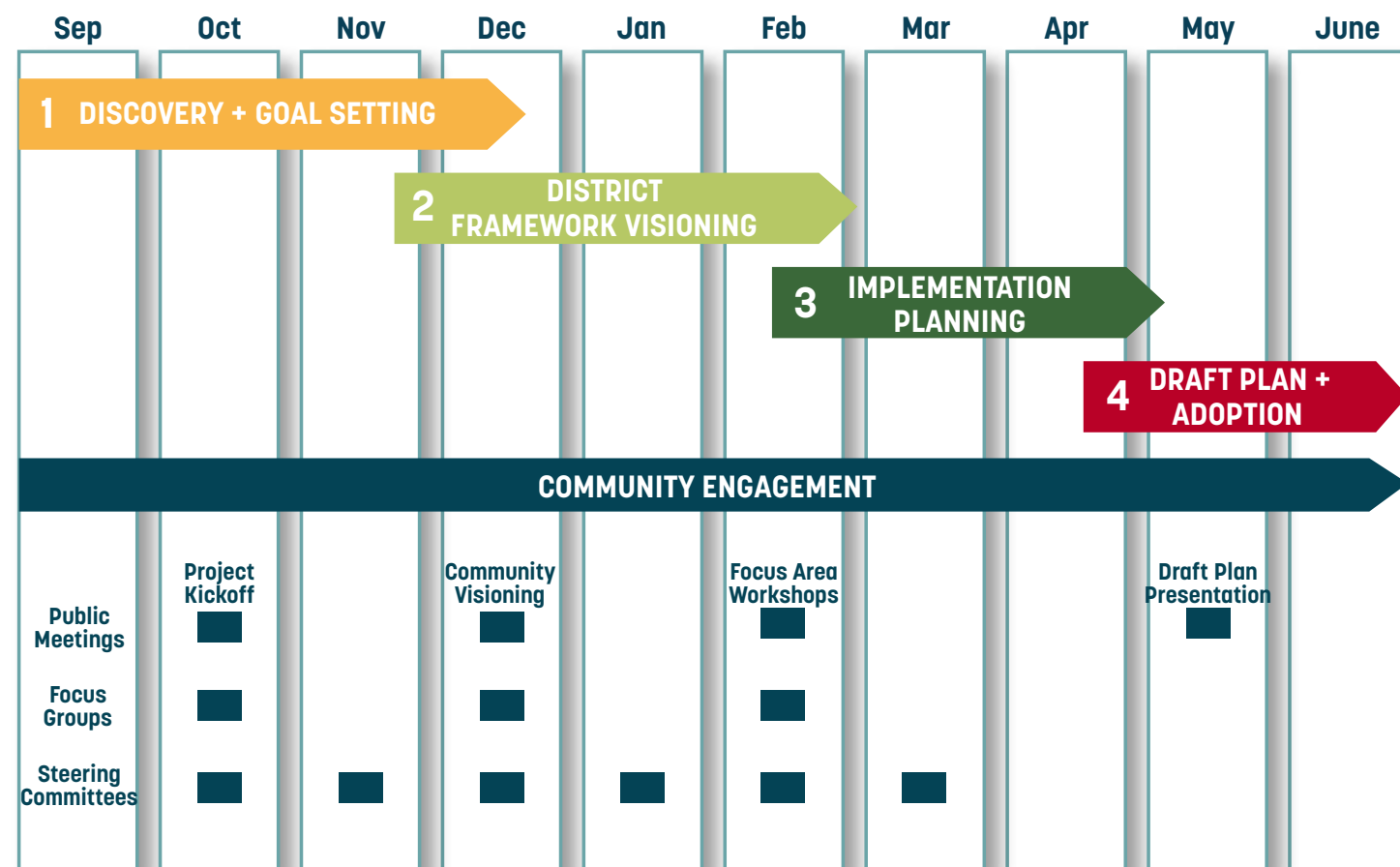

The interdisciplinary planning team, led by Sasaki, consisted of both local and national firms. This combination of firms was able to provide relevant case studies and research from around the country while rooting the visions for Little Rock within the local context.

The City of Little Rock, the Downtown Partnership, local community groups, stakeholders such as business owners and Downtown residents, property owners, local

agencies, and the Little Rock community beyond the downtown boundary all provided feedback that guided the establishment of the vision, values, big ideas, and ultimately implementation strategies for the city's first ever Downtown Master Plan.

ENGAGEMENT

Groups and Outreach

The Master Plan was guided by community feedback which was collected through multiple avenues including public meetings, pop-up events, and online surveys. The planning team also engaged students at local K-12 and higher education institutions to receive ideas and feedback from many generations of the Little Rock community. In addition to hosting these events, the planning team consistently met with the project's committees and focus groups that were composed of local community leaders and advocates.

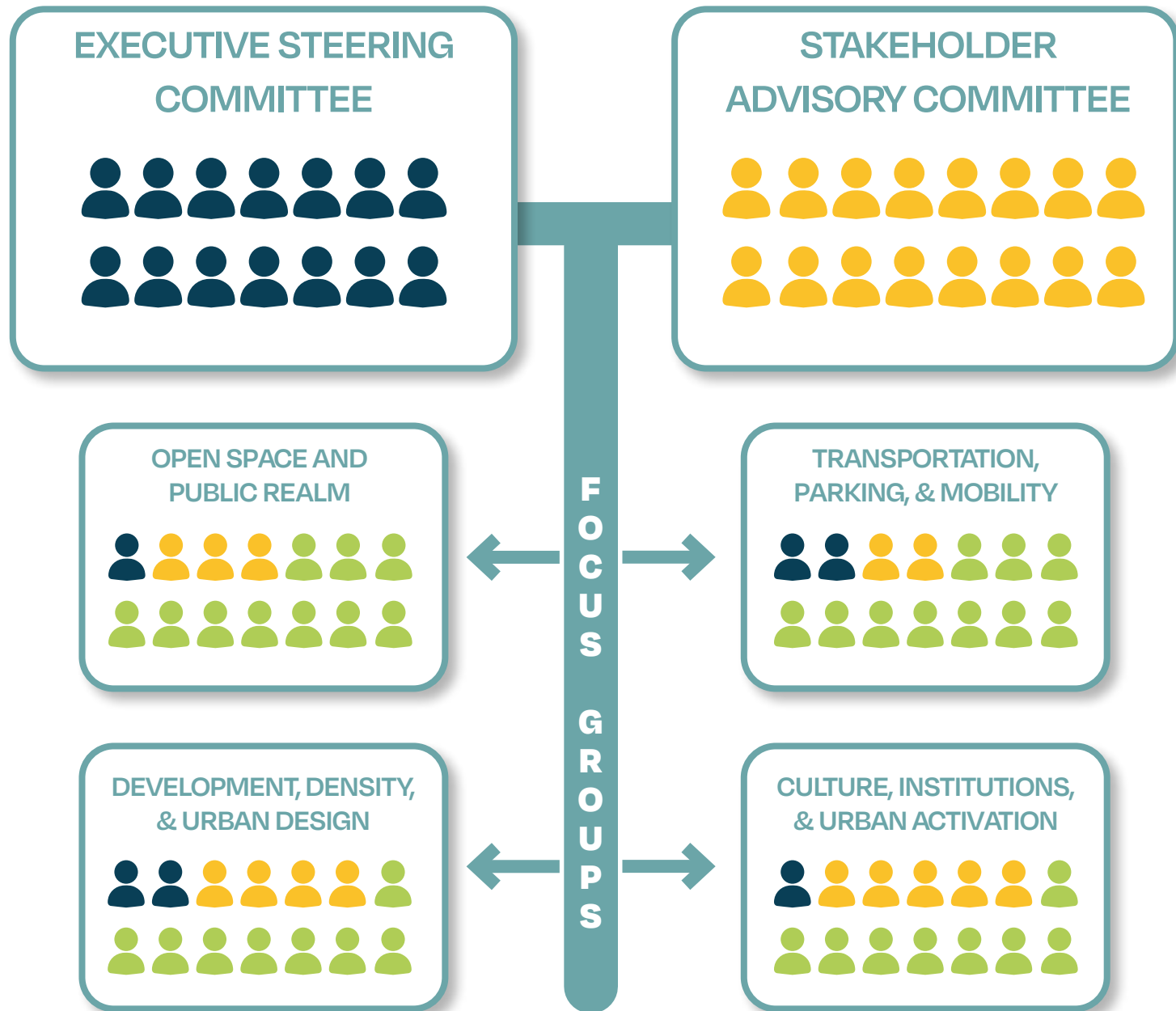
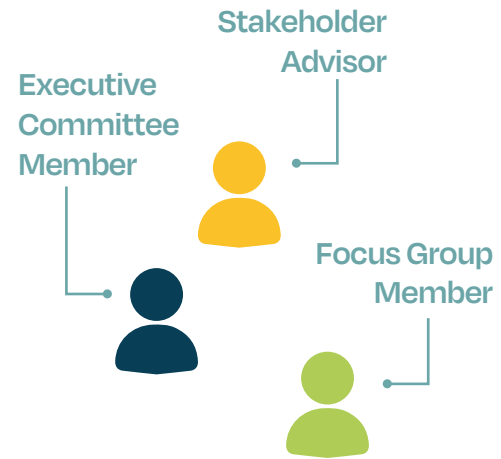

TOUCH POINTS

1,945 Survey Responses	4 Surveys
650 Public Meeting Attendees	7 Public Meetings
18 Focus Group + Committee Meetings	7 Pop-up Events



BIG IDEAS

The Discovery and Goal Setting phase resulted in four Big Ideas that outline visionary and bold strategies for achieving the desired shared vision for Downtown. These ideas create a central guiding framework for the Master Plan.

A Tapestry of Neighborhoods



Build off existing character to establish an identifiable neighborhood pattern and support residential growth.

Loop, Stitch, and Reconnect

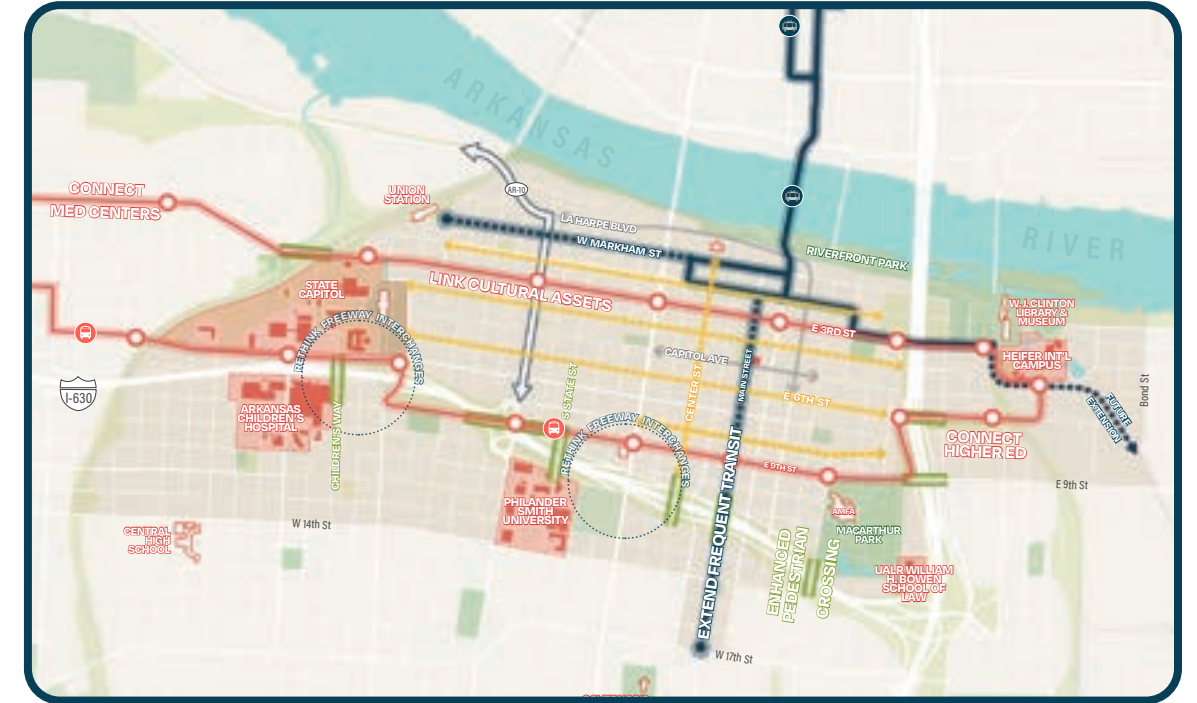

Reposition transit and transportation networks to connect people from where they are to where they need and want to go.

Rambles to the River

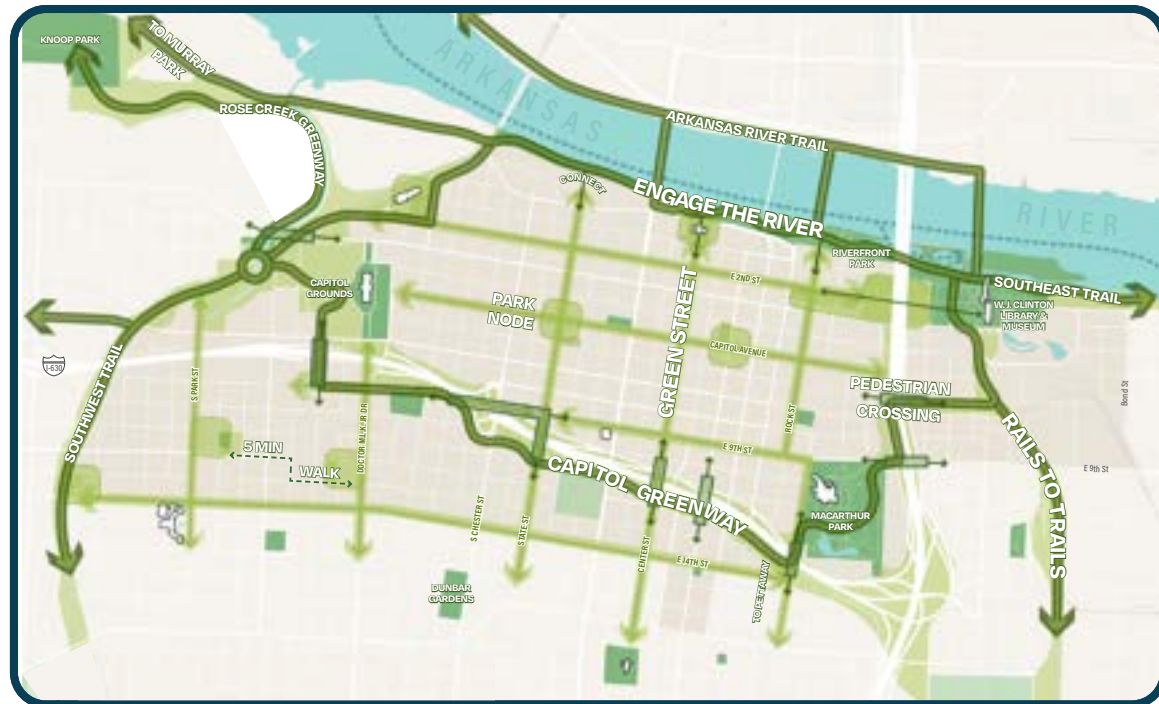

Create an interconnected network of trails, green streets, and park nodes.

Culture as a Catalyst

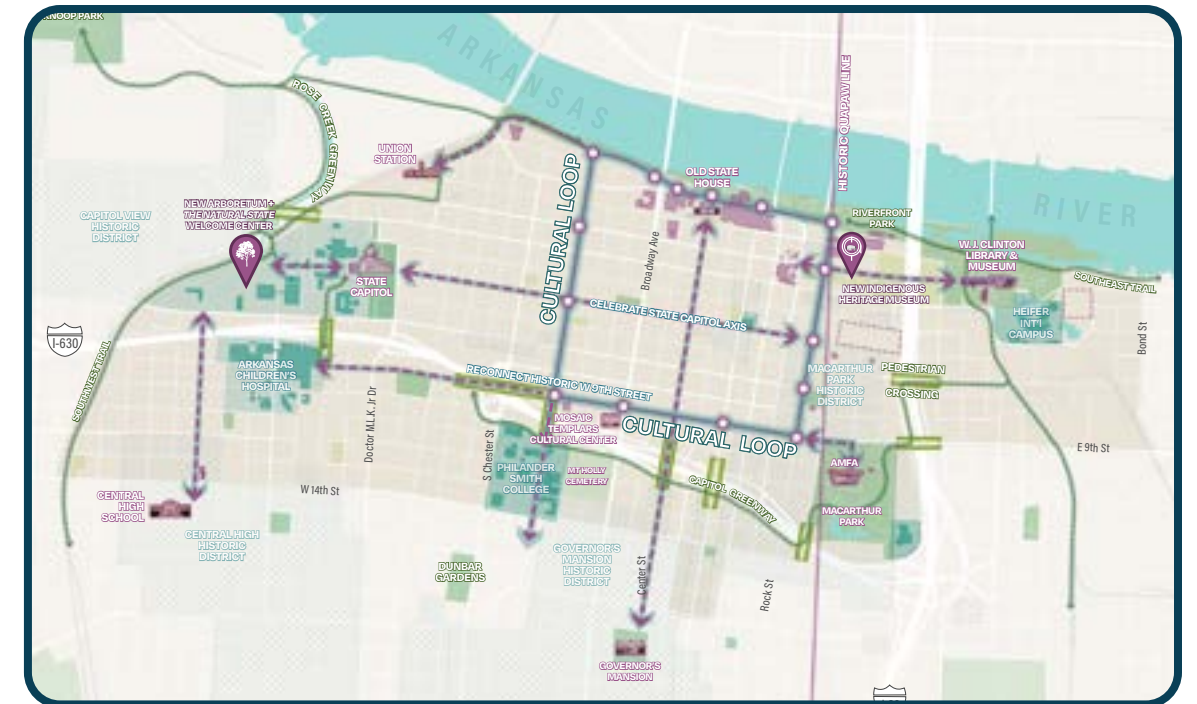

Utilize cultural and historic assets as a catalyst for growth, community identity, and placemaking.

FOCUS AREAS

The four Big Ideas combine to create an overall framework for the Downtown Master Plan. Within that framework, sit four focus areas with tangible implementation strategies to bring the Big Ideas, Six Values, and the Vision Statement to life.

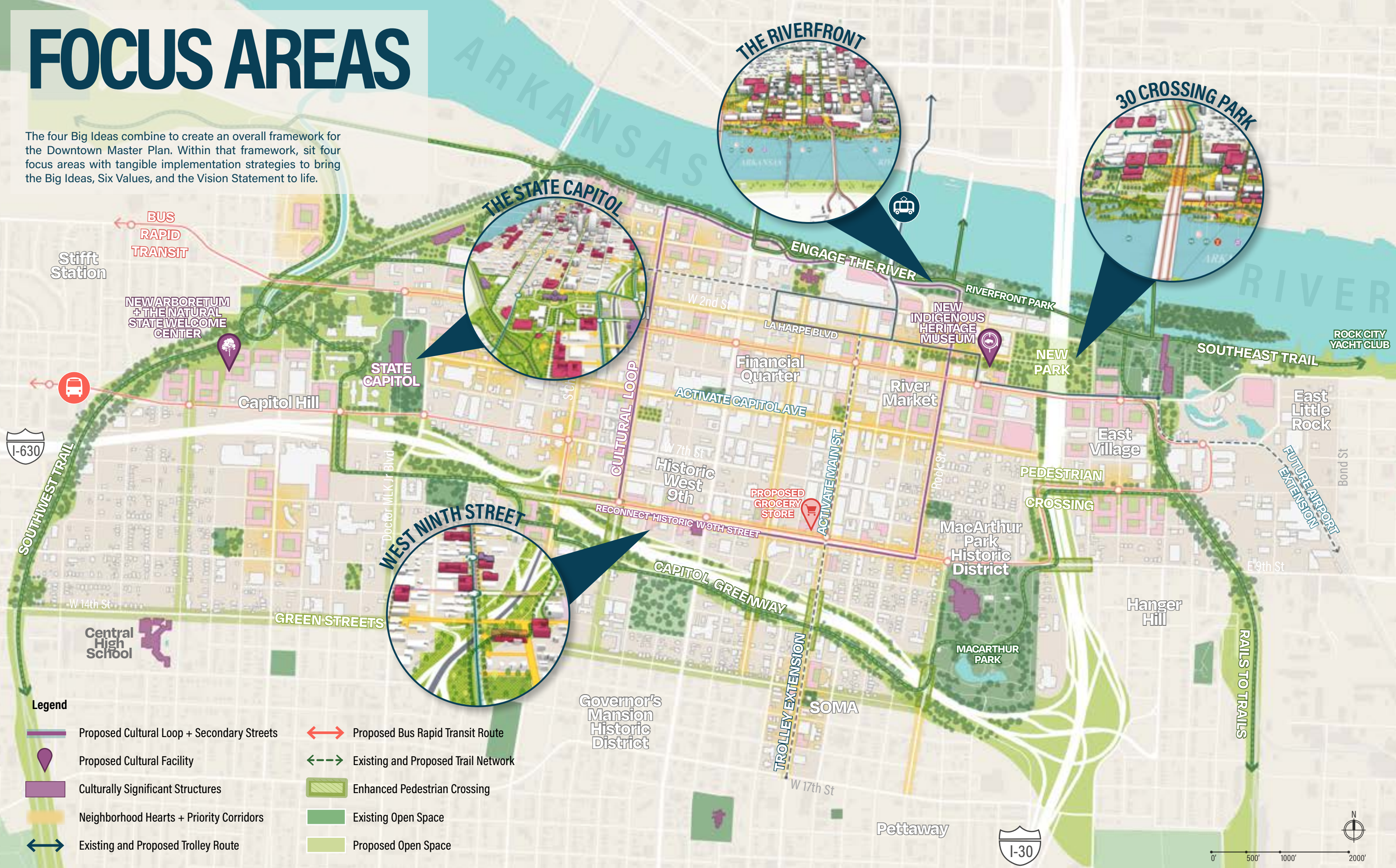

Legend

- Proposed Cultural Loop + Secondary Streets
- Proposed Cultural Facility
- Culturally Significant Structures
- Neighborhood Hearts + Priority Corridors
- Existing and Proposed Trolley Route
- Proposed Bus Rapid Transit Route
- Existing and Proposed Trail Network
- Enhanced Pedestrian Crossing
- Existing Open Space
- Proposed Open Space

THE RIVERFRONT

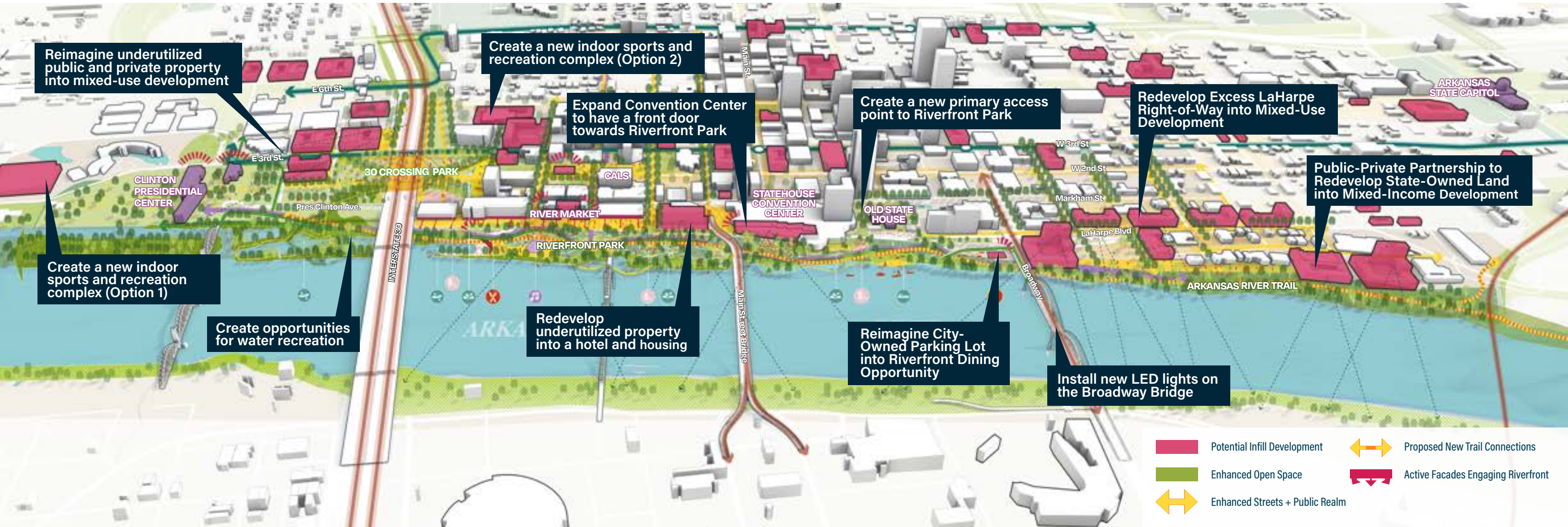

The Arkansas River defines Downtown Little Rock. Although the City has made improvements along the river's edge in Riverfront Park, the urban fabric of the city continues to turn its back towards the water. Reimagining the open spaces and development along the river is essential for unlocking success in the area and in creating high quality of life amenities to make living and working Downtown superior

to other neighborhoods in Central Arkansas. Key goals to achieve this include reimagining LaHarpe Boulevard as a slow, two-lane street, enhancing the facades of existing buildings near the river, and redeveloping publicly-owned land into mixed-use development to drive activity and vibrancy.

30 CROSSING PARK

Reimagine public parking lots into mixed-use development to help fund new park

Consider opportunities for celebrating Arkansas' Indigenous History

Reimagine public parking lots into mixed-use development to help fund new park

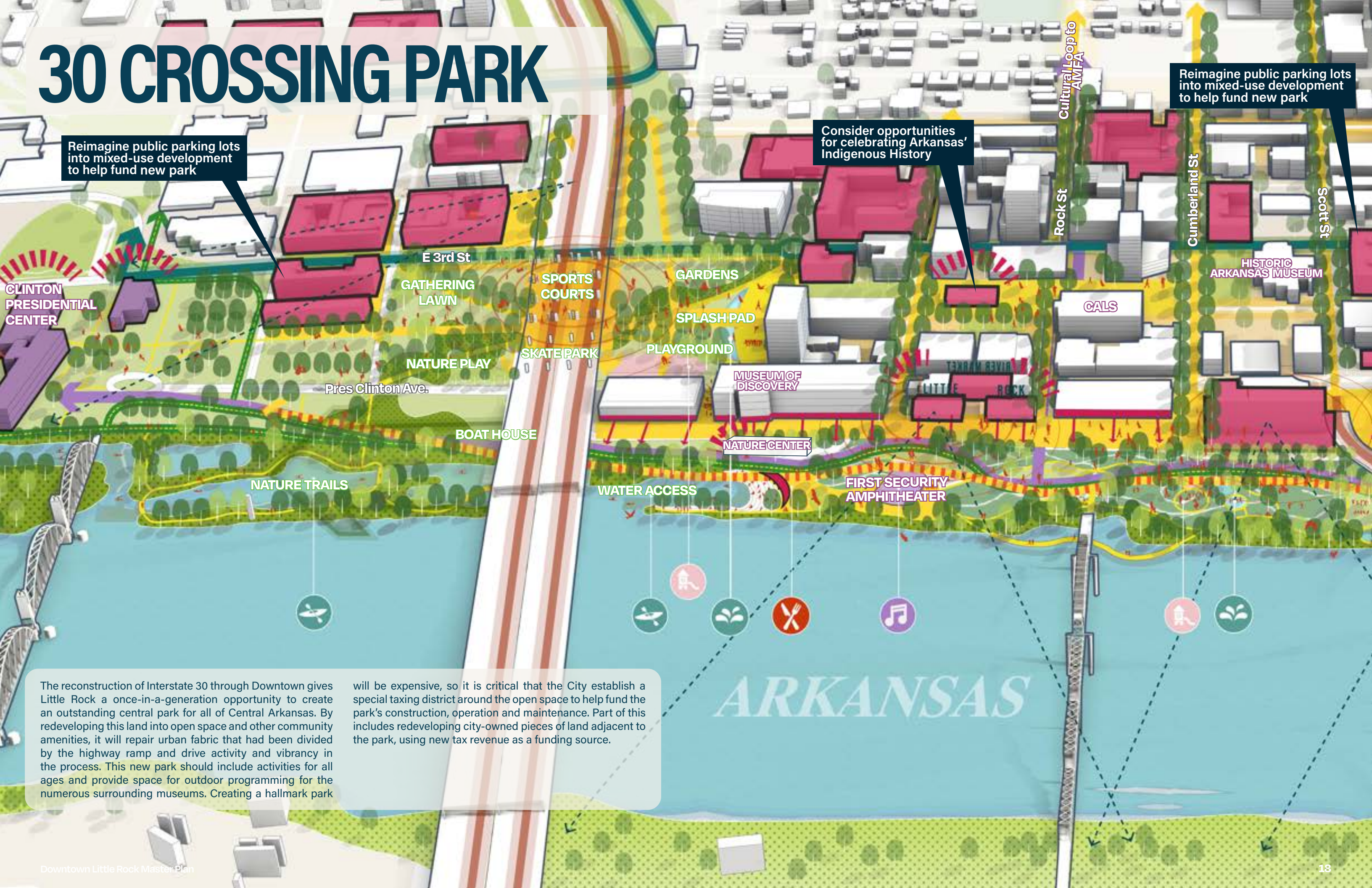

The reconstruction of Interstate 30 through Downtown gives Little Rock a once-in-a-generation opportunity to create an outstanding central park for all of Central Arkansas. By redeveloping this land into open space and other community amenities, it will repair urban fabric that had been divided by the highway ramp and drive activity and vibrancy in the process. This new park should include activities for all ages and provide space for outdoor programming for the numerous surrounding museums. Creating a hallmark park

will be expensive, so it is critical that the City establish a special taxing district around the open space to help fund the park's construction, operation and maintenance. Part of this includes redeveloping city-owned pieces of land adjacent to the park, using new tax revenue as a funding source.

THE STATE CAPITOL

Capitol Avenue is a ceremonial street and mixed-use civic corridor connecting core of Downtown to State Capitol

Public-Private Partnership to Redevelop State-Owned Parking Lots into Mixed-Income Housing

Reimagine Marshall Street bridge with enhanced pedestrian and bike facilities

Connect State Capitol to the Arkansas River via Rose Creek Greenway and Southwest Trail

Public-Private Partnership to Redevelop State-Owned Parking Lots into Mixed-Income Housing

The Arkansas State Capitol anchors the western edge of Downtown and yet the grounds and the surrounding area is a sleepy area of parking lots and underutilized land. Planned and proposed trails have the potential to transform the Arkansas State Capitol grounds into the epicenter of the Central Arkansas regional greenway network. By reimagining excess State-owned property as public open space, outdoor educational space, and private development opportunities,

the State Capitol can reinforce itself as an anchor on the western edge of Downtown. The plan imagines the grounds as a space for recreation, living, working, and playing that connects people to nature and reinforces it as the center of The Natural State.

WEST NINTH STREET

A new Black Entrepreneurship and Incubator Hub could be built on existing surface parking lots

West 7th and Chester has existing assets and should be reimagined as a neighborhood heart

The State Street Bridge should become a pedestrian-only bridge connecting Philander Smith to West Ninth

Excess ARDOT right-of-way should be transformed into a cultural memorial space

Public-Private Partnership to Redevelop Excess ARDOT right-of-way into Affordable Housing

West Ninth Street was historically Little Rock's Black Main Street. Unfortunately, its significance was destroyed by the construction of Interstate 630 many decades ago. Building off key anchors such as the Mosaic Templars Cultural Center and The Hall, West Ninth Street should once again become a cultural spine, anchoring the southern end of Downtown while connecting key assets such as the Arkansas Museum of Fine Arts to Arkansas Children's Hospital. Strategies

for the area should include the creation of a new Black Entrepreneurship and Incubator Hub, the reconstruction of the roadway with robust public realm as a part of the proposed Cultural Loop, new infill development, and enhanced bridge crossings over the interstate. Long-term, a new deck park should better connect the two sides of the interstate, and a new bridge for West Ninth Street should be built to reconnect the divided street.

MOSAIC
TEMPLARS
CULTURAL
CENTER

THE HALL

MOUNT HOLLY
CEMETERY

PHILANDER SMITH
UNIVERSITY

NINTH
STREET
PARK

RECONNECT HISTORIC WEST NINTH STREET

INTERSTATE 630

Broadway

State St

Chester St

Ringo St

Cross St

W 8th St

W 7th St



2

Introduction



Source: Caldwell, Paul



Why Do a Downtown Master Plan?

Downtown Little Rock is at the very center of the State of Arkansas. It is the nexus of government, education, and culture for the entire state. Its historic significance cannot be overstated. From its establishment as the Territorial Capital of Arkansas, to the Trail of Tears, the Civil War, and Civil Rights movements, Downtown Little Rock has always been at the crossroads of history, politics, and importance.

Downtown Little Rock once again finds itself at a crossroads. As downtowns across the nation venture into a post-COVID world, the uncertain future has created a sense of fear regarding the role of downtowns in the modern economy. Downtown Little Rock, like other cities, is experiencing a loss of office employment, increasing vacancy of retail establishments, and perceptions of poor safety. At the same time, Downtown Little Rock has numerous recent and upcoming investments that have the possibility of catalyzing great change, transforming downtown, and reestablishing it as the epicenter of Arkansas in the years to come. Leveraging these investments as the starting point for even greater growth and investment is critical as Downtown Little Rock looks to position itself locally, regionally, and nationally in the years to come. The Downtown Little Rock Master Plan is the road map which provides the vision, recommendations, and tools to do just that.

The Downtown Little Rock Master Plan is the first ever comprehensive master plan for Downtown Little Rock. The goal is to create a strategic vision for growth and development in order to guide a better future for downtown and its users. The vision laid out in this master plan will serve as a road map for future decision making by the City of Little Rock, the development community, other associated agencies, specific neighborhoods, and individuals in order to build the future desired by its stakeholders. This will include enhanced multimodal connectivity both within the district and to other areas, a safe and vibrant public realm, and improved public open spaces, all with the goal of increasing quality of life for residents, workers, and visitors.

The Downtown Master Plan, funded by the City of Little Rock and conducted in collaboration with the Downtown Little Rock Partnership, was a nine-month long planning effort that established strategic goals and actions around topics such as development, urban design, streets, mobility, and parks and open space. The Downtown Master Plan was achieved through a process of co-creation with the community. The planning team, Sasaki, the City, and the Downtown Partnership listened to all stakeholders and citizens in order to understand their vision and aspirations for their urban heart.

DTLR HISTORY

Through the Years

Downtown Little Rock has a rich history that is important to both Arkansas and the entire nation. Prior to White settlement, the area now known as Little Rock was largely Quapaw land, although the Caddo and Osage nations were also present. Downtown Little Rock, founded as a trading post in 1812, is the oldest continuously inhabited White settlement in Arkansas and thus contains some of the State's most important historical and cultural sites. Understanding the many histories that have occurred in Downtown Little Rock is critical in shaping a plan that can mold Downtown into the future.

Indigenous Land

Prior to White settlement, the area now known as Little Rock was largely Quapaw land. The Plum Bayou culture (650-1050 CE) established a ceremonial center several miles east of Little Rock near present-day Scott. The French explorer Jean Baptiste Bénard de La Harpe was the first European to discover Little Rock in 1722, naming the location "la petite roche" after the small outcropping in the Arkansas River. Arkansas was purchased by the United States through the Louisiana Purchase in 1803, and permanent European settlement occurred in Little Rock soon thereafter in 1812, with the establishment of a trading post in present-day Downtown.

Territorial Establishment

As more settlers moved to Little Rock, pressure grew to remove the existing Indigenous nations who called the land home. In 1818, the Quapaw Line was drawn, extending due south from "la petite roche", demarcating lands east of it as for the Quapaw nation and lands to the west as for American settlers. This treaty was ignored just three years later as settlers moved into Quapaw lands east of the line. In the 1830's, the Federal Indian Removal Act forcibly relocated indigenous nations from the Eastern United States to present-day Oklahoma via the Trail of Tears, which passed through Little Rock. In 1831, Little Rock was named Arkansas' territorial capital, and in 1836 the territory was admitted to the Union as a slave state.

Civil War

In 1861, Arkansas seceded from the Union and joined the Confederate State of America. Soon thereafter, Little Rock, along with the rest of the state, was embroiled in the Civil War. In September 1863, the Union successfully recaptured the capital city in the Battle of Little Rock. Union forces would occupy the City until 1868 when Arkansas was readmitted to the Union. In the decade following the Civil War, Reconstruction saw a fight for power amongst various political groups, concluding with the Brooks-Baxter War in 1874, which brought an end to Republican rule of the state.



The 17th century Quapaw village of Osotouy, by Kugee Supernaw.

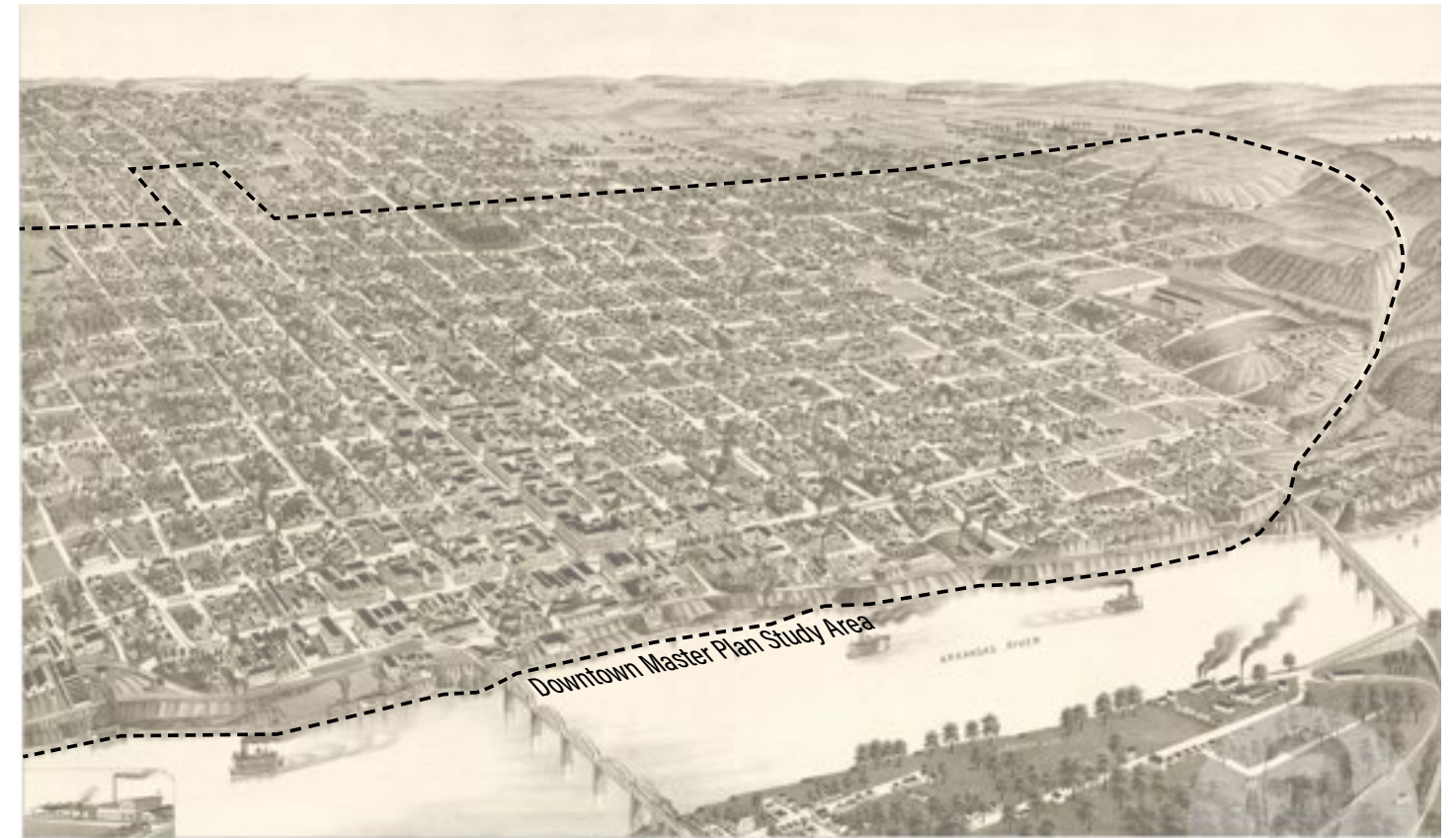

1887 City of Little Rock. Perspective by Henry Wellge & Co.

The Gilded Age and Progressive Era

The years after Reconstruction saw great growth in Little Rock. This growth saw the establishment of many modern facilities, such as the railroad, telephone, and electric streetcar, and institutions which remain to this day, including the Capital Hotel and UAMS. The population of Little Rock grew from 3,700 in 1860 to 88,000 by 1940. Many of Downtown's most notable buildings were constructed during this period, including City Hall (1908), the Boyle Building (1909), the Arkansas State Capitol (1912), the Mosaic Templars Cultural center (1913), and the Donaghey Building (1926).

Post-World War II

After World War II, Western expansion, along with significant urban renewal projects which destroyed numerous buildings in the Downtown core resulted in gradual disinvestment. Retailers flocked away from Main Street to suburban shopping centers, while the proliferation of the automobile and new office tower construction saw the demolition of the historic urban fabric for surface parking lots. Although attempts were made to reimagine Main Street into a more modern shopping district in the 1970's, they were short-lived. Around this same time, I-630 was completed, destroying hundreds of buildings and severing neighborhoods from Downtown in the process. The 1980's did see reinvestment in key assets along the Arkansas River and construction of many of the tallest office buildings in the Financial Quarter.

Recent Reinvestment

Like many downtowns nationally, the end of the 20th Century saw a renewed interest in reinvestment in Downtown Little Rock. The construction of the River Market Pavilions and Ottenheimer Hall in 1996 jump started new reinvestment in the northeast corner of downtown, which included the construction of a new Central Arkansas Library System (CALs) Main Branch (1997), the construction of the William J. Clinton Presidential Library and Museum (2004), the construction of the Metro Streetcar (2004), and new pedestrian bridge enhancements on multiple bridges over the Arkansas River.

Following the slowing of the economy with the Great Recession in 2008, investment in Downtown has slowed. New office and residential developments have largely been adaptive reuse of historic buildings. That said, investments in the East Village neighborhood and South Main (SOMA) have created vibrancy in those areas. Other notable reinvestments include the reconstruction and expansion of the Arkansas Museum of Fine Arts (AMFA), the construction of a new Arkansas Symphony Orchestra headquarters, and planned expansion of Arkansas Children's Hospital.

HISTORIC TIMELINE

12,000 BCE - 1880 CE

1722
French Explorer Jean-Baptiste Bénéard de La Harpe named rocky bluff “la petite roche,” or “the little rock.”



Source: Chandler, Wil

EUROPEAN SETTLEMENT



Source: Little Rock Culture Vulture

1820
Little Rock received first **post office**.
1822
First **steam boat** arrived via Arkansas River (above).
1823
Jesse Brown opened **first school** on Rock Street.

1836
Arkansas admitted to **Union** as a slave state.

1841
The Anthony House, Little Rock’s first real hotel, opened on Markham Street, before burning down in 1875.

1842
Old Statehouse at Markham and Center completed (below).



Source: CALS



Source: William Steele

1860 - 1861
Gas lighting and **telegraph** came to Little Rock.

1861
Civil War began (left). Arkansas seceded from Union.

1863
Battle of Little Rock. Union successfully pushed Confederates out of Little Rock (below).



Source: Library of Congress

CIVIL WAR AND RECONSTRUCTION

1873 - 1874
Railroad reached Little Rock with the building of the **Baring Cross Bridge** and first train station



Source: Library of Congress



Source: Library of Congress

1877
Capitol Hotel opened on the corner of Markham and Louisiana Streets.

1879
Sperindio Hotel on Second Street purchased and renovated into first medical school (UAMS). **First telephone exchange** occurred in Little Rock.

INDIGENOUS AMERICAN SETTLEMENT

12,000 BCE

12,000 BCE -
Indigenous Americans settle the Little Rock area — specifically the Caddo, Osage, and Quapaw peoples.

650 - 1,050 CE
Plum Bayou culture constructed early ceremonial community centers.



Source: Ford, Paige A.

1800

1818
Quapaw Line drawn. The Quapaw people were later forced to give up their land.



Source: Little Rock Convention & Visitors Bureau

1812
First known squatter, **William Lewis**, camped on Quapaw land.

1825

1830's
Federal Indian Removal Act of 1830 incited the **Trail of Tears**, which passed through the Little Rock area.



Source: Arkansas Democrat Gazette

1831
Arkansas territorial capitol moves to Little Rock, which later incorporates and **becomes a city** in 1835.

1828
Hinderliter Grog Shop built (oldest remaining building in Little Rock today).



Source: Historic Arkansas Museum

1850

1853
Free schools for white boys and girls started.

1865
Civil War ended (left). Arkansas readmitted to Union in 1868. Soldiers buried in Oakland & Fraternal Historic Cemetery Park. The **Convention of Colored Citizens** held in Little Rock united African Americans in the state (below).



Source: CALS

1875

1870's Reconstruction Era. The Brooks-Baxter War of 1874 in Little Rock brought a practical end to Republican rule in the state, thus ending the Reconstruction Era.



Source: Arkansas Heritage

HISTORIC TIMELINE

1883-1964



Source: CALS



Source: City of Little Rock

1891
Arkansas Power & Light Co. converted mule-drawn street cars to **electric street cars** (left, above).

1892
African American man, **Henry James**, lynched on Capitol Avenue.

1893
U.S. government deeded **arsenal** at 9th and Ferry to city, which later became **MacArthur Park** in 1942. (Left, below).

1897
“**Free Bridge**,” first non-railroad bridge, built across Arkansas River.

1899
Rock Island Bridge built as railroad bridge. It was later converted to pedestrian bridge in 2011 (below).



Source: CALS

1912
Municipal garbage collection started.

1914
New **Arkansas State Capitol** completed (above).

1927
Little Rock High School (now Central High School) opened and was largest high school in the nation until 1940's (below). **The Flood of 1927** washed away part of Baring Cross Bridge.



Source: Hadley Company



Source: Tichnor Brothers

1937
AMFA opened in MacArthur Park (above).

1940
Department stores like Pfeiffer and Blass and M.M. Cohn pull shoppers from all over Arkansas toward downtown. **Robinson Center** opens.

1950's - 1980's
White people left racially mixed downtown for suburban areas (known as **white flight**). Many suburban shopping centers emerged (below).



Source: Saunders, Earl Jr.



Source: CALS

1960
Winthrop Rockefeller built **Tower Building** as tallest building in state and fuels construction of **Arkansas Arts Center**, **Park Plaza Shopping Center** (and others) opened, pulling shopping and retail out of city core (left).

1961
City receives \$47 Million to fund **Urban renewal program**, demolishing numerous buildings including on W. 9th St.

THE GILDED AGE

SUBURBAN GROWTH AND URBAN DECLINE

1880 1900 1925 1950

1883
Electric service introduced to Little Rock.

1887
First streets paved with **cobblestone** and **first sewer lines** laid in Little Rock.

1889
Pulaski County builds its **first courthouse** on West 2nd Street.



Source: Govt. Printing Office

1903
City decreed **segregation** on city streetcars. **3rd Street viaduct** built. Little Rock's Eighth Ward voted to secede from Little Rock to become **North Little Rock**.



Source: Arkansas State Archives

1907
Marion Hotel and Southern Trust Building (Little Rock's first skyscraper) opened.

1908
City Hall at Markham and Broadway completed (right).



Source: Dunn, Bob

1900 - 1950 West 9th Street (left) became heart of African-American community and experienced terrible violence in 1927 when a white mob lynched **John Carter** and ransacked the neighborhood. **Mosaic Templars (Cultural Center)** reconstructed as museum of African American history.

1926
Donaghey Building completed as tallest building in the state (right). **Velvutex College of Beauty Culture**, then the state's only approved beauty school for people of color, incorporated (below).



Source: CALS



Source: CALS

1957
Against much opposition, “**Little Rock Nine**,” were first African American students to enter Central High School. **Labor Day Bombings** of 1959 occurred in response to these progressive changes.



Source: CALS

1963
I-30 completed through Downtown Little Rock (below). **1964**
Quapaw Quarter Historic District formed to save old homes on east side of downtown.



Source: Saunders, Earl Jr.

HISTORIC TIMELINE

1965- Today

1968
The Little Rock Uprising of 1968 (right) responded to questionable death of young black man, Curtis Ingram, in penal system.
1969
 Little Rock Junior College merged with University of Arkansas as **University of Arkansas at Little Rock**. Little Rock's **modern port**, with 1,500-acre industrial park and shortline railroad, went into operation.



Source: Arkansas History Commission

1972
 Present **terminal** at Little Rock National Airport built.
1974
 Little Rock hosted second **National Black Political Convention**.

1980's
 Downtown renovations include Capital Hotel, Continental Building, and Heritage Center.
1982 - 1987
 RiverFest moved to Downtown in 1982. Julius Breckling Riverfront Park opened in 1983. First Security Amphitheater (below) opened in 1987.



Source: Trip Advisor



Source: Little Rock Culture Vulture

1992 - 2000
 Arkansas Governor **Bill Clinton** accepts the presidency of the United States in 1992 and 1996 on the steps of the Old State House (above).

1997
Main Library opened in renovated Fones Brothers warehouse on Rock Street in River Market District.
1998
Little Rock Central High School designated by the National Park Service.
1999
ALLTEL Arena, an 18,000 seat multi-purpose facility, opened in North Little Rock.

2006
 Pulaski County Pedestrian/Bicycle Bridge, popularly known as **Big Dam Bridge**, opened (second-longest bridge built for pedestrians in North America). **Heifer International** world headquarters opened.
2007
River Rail service extended to the William J. Clinton Presidential Center and Park and the Heifer International world headquarters.

2023
 Clinton Foundation announced plans for **Clinton Presidential Center expansion**. Arkansas Attorney General Tim Griffin announced plans to relocate his office to historic **Boyle Building** in downtown Little Rock in late 2024.

SUBURBAN GROWTH AND DECLINE, CONT'D

NEW CENTURY, NEW FUTURE

1975

1990

2000

2025

1970's
 Downtown's main department stores closed or relocated to suburban locations. **Metrocentre Mall** opened in 1973 to revive Main Street. Improvements removed by late 1980's. Pedestrian-only **Main Street Mall** opened in 1987 (bottom), but permitted vehicular traffic again in 1991.



Source: Durning, Dan



Source: Ardrey, Jess

1980
 Marion and Grady Manning Hotels razed to make way for **Excelsior Hotel and Statehouse Convention Center**.

1985
I-630 completed through downtown, reflecting racial divides in city (below).
1986
Simmons First National Bank Tower at Broadway and Capitol completed as the tallest building in Arkansas (formally known as TCBY Tower and Metropolitan National Bank Building).



Source: Roher, Acadia

1996
 Abandoned warehouse on East Markham Street becomes home to new **River Market and Farmer's Market**. **Doubletree Hotel**, formerly Camelot Hotel, opened.



Source: Little Rock Convention & Visitors Bureau

1999
 Addition to the Statehouse Convention Center expands total size to 220,000 square feet.

2003 - 2004
First Little Rock Marathon. **William J. Clinton Presidential Center** completed. **"River Rail"** streetcar line opened to connect Little Rock's River Market District with North Little Rock's downtown.

2010
Eugene Ellison killed by member of the Little Rock Police Department.
2016
 Major renovation and expansion of Robinson Center completed.

2018
Frank Scott Jr. became first African American elected mayor of Little Rock (Charles Bussey Jr. and Lottie Shackelford had previously served as mayor but were elected by city's board of directors).
2019
Arkansas Flood of 2019.

PAST PLANS

1913-Today

Although the Downtown Little Rock Master Plan is the first-ever master plan for the downtown area, there have been other plans and studies that serve as the foundation for this planning effort. Many of these plans, though many years old, hold long-established visions that still ring true in 2023.

1913 Parks Plan

In 1913, the City of Little Rock hired famed landscape architect John Nolan of Cambridge, Massachusetts to complete a vision study for the entire city, focusing on the parks system and public realm. Although many of the recommendations of this plan were not implemented either in full or at all, the plan contains a great understanding of the natural context and potential of the city to uniquely position itself physically within the Ouachita Mountain foothills in order to define the urban design of the city.

Key recommendations within the plan include embracing the city's relationship with the Arkansas River, including connecting the Old State House and surrounding development better to the waterfront. Another central recommendation is to cement the State Capitol as a significant moment within the urban fabric, while also connecting the State Capitol grounds to Rose Creek and the neighborhoods to the south and west. Additionally, ideas existed to establish a series of greenways and green boulevards along key corridors to connect open spaces and enhance quality of life for neighborhoods around those corridors. All of these considerations could hold water today and are worthy of exploration.

1982 Downtown Plan

The 1982 Downtown Little Rock Development Plan, led by Hodges, Vines, Fox, and Associates, outlined considerations for recreation, tourism, and entertainment in the Downtown core, as well as opportunities to improve existing public assets such as Riverfront Park, the County Courthouse, City Hall, the Old State House, and the Convention Center. The plan reimagined traffic patterns in downtown, including advocating for one-way traffic flow and new parking systems. Most importantly, the plan laid the foundation for the creation of the River Market and the River Market District.

2001 Parks Master Plan

The 2001 master plan set a twenty-year vision to make Little Rock a "city within a park." Goals for executing this vision included creating an interconnected multi-functional open space system that includes parks and trail networks. Within the system, special facilities would serve as anchors of activity which would be supported by smaller neighborhood parks that are no more than eight blocks from any-given resident.

A proposed three-trail loop system surrounding the parks would create a uniting framework. The master plan also set a standard for the number of acres per 1000 people for each park land and facility type.

2012 Main Street Creative Corridor Study

Conducted by the University of Arkansas Community Design Center and Marlon Blackwell Architects, the Main Street Revitalization Creative Corridor Study aimed to create a vision for reimagining Little Rock's Main Street as the hub of commerce and activity that it had been in decades prior. This urban design study, funded by the National Endowment of the Arts, served as the impetus for the Greening America's Capitals EPA grant, which reconstructed a five block stretch of the road with stormwater infrastructure and enhanced public realm.

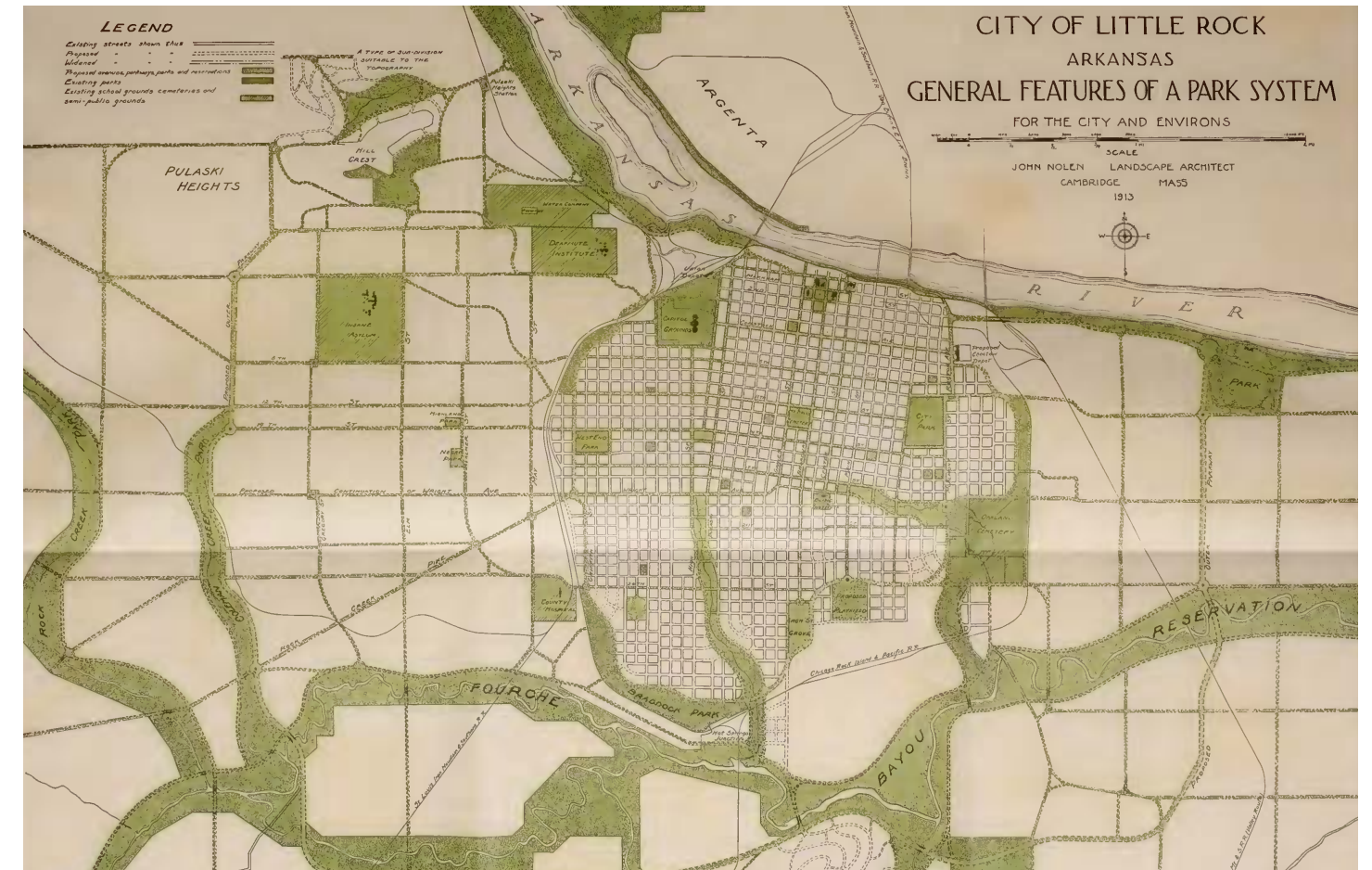

2023 Tourism Master Plan

The most recent study that helped inform the foundation of the Downtown Master Plan was the 2023 Little Rock Convention and Visitors Bureau Tourism Master Plan. This comprehensive document looked more broadly at the entire city and identified key drivers that the city should focus on to further drive tourism. Focus points included trail development and riverfront access, placemaking, connectivity between tourism assets, improved marketing, better utilization of the Statehouse Convention Center and Robinson Center, improved diversity, equity, and inclusion efforts, and enhanced perceptions of the City. All of these themes also emerged through the Downtown Master Planning effort.

Complete Streets Ordinance

The Complete Streets Ordinance, including the Complete Streets: Bicycle Plan, still under development at the time of Downtown Master Plan drafting, outlines citywide on-street and trail enhancements to improve multimodal mobility. Specific projects outlined for Downtown include a north-south corridor along State Street, an east-west corridor along either 3rd or 4th Street, and an extension of existing facilities along 7th Street. Although the plan highlights additional streets for consideration, there is no dedicated funding for enhancements right now.

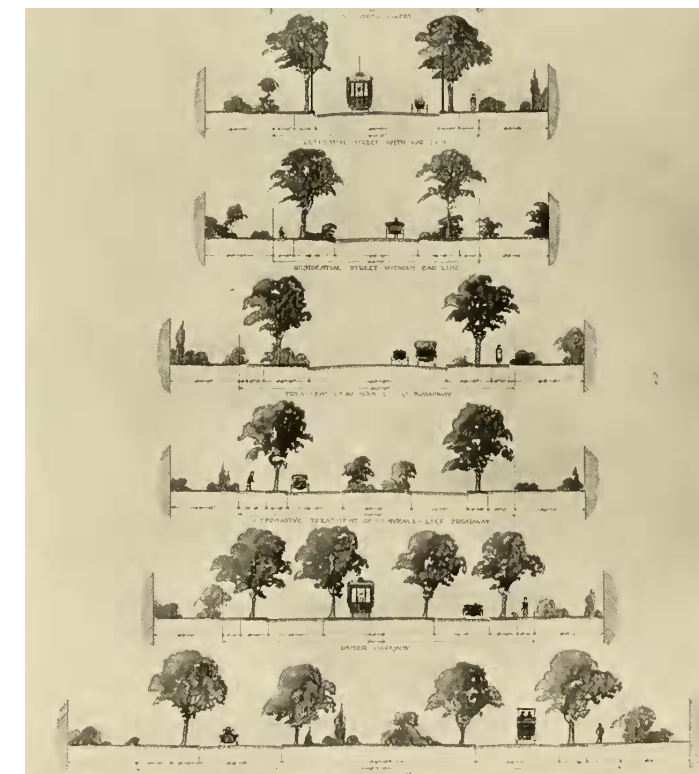

Graphics from 1913 Parks Plan. Right: Suggested Treatment for Streets and Avenues. Top: 1913 Parks Plan System Map

A DYNAMIC CENTER

Key Projects



Key Recent & Ongoing Projects

Downtown Little Rock is fortunate to have numerous recent and ongoing projects that will reshape the future of the urban core. These projects range in scale and type, but all will work to increase activity, promote economic development, and support cultural incubation.

Recently completed projects include the expansion and renovation of the Robinson Center and the renovation and expansion of the Arkansas Museum of Fine Arts (AMFA) in MacArthur Park. Projects currently underway include the expansion of the Little Rock Tech Park on Main Street, the

reconstruction of I-30 through Downtown, the renovation of the Boyle Building on Main Street, and the construction of a new headquarters building for the Arkansas Symphony Orchestra.

Key Upcoming Projects

In addition to the recently completed and ongoing projects, Downtown also has numerous upcoming projects that will reinforce economic growth and should improve the quality of life for residents and guests to the area.

- » Expansion of Arkansas Children's Hospital
- » William J. Clinton Presidential Center and Library Expansion
- » I-30 Deck Park Study
- » Central Arkansas Library Systems (CALS) Main Branch renovation
- » A reimagination of the River Market pavilions

3



Discovery



Source: T-Mobile



Downtown Analysis

Understanding the existing conditions in Downtown Little Rock was critical to identify challenges, barriers, strengths, and opportunities. The various urban systems analyzed in order to better understand these opportunities and constraints were: Fabric, Parks, Mobility, Economy, Culture and Community Perceptions.

These six key systems are intricately linked with each other and have served to establish Downtown Little Rock as the urban center for the State of Arkansas. At times, these systems have also acted as impediments to growth and long-term success. Unpacking each of these systems through geospatial and empirical analysis, along with robust input from the Downtown community, helped to identify key issues that needed to be understood further. Additionally, it helped to shape the emerging vision and key themes that became the core of the Downtown Master Plan, informing action items and recommendations.





Detailed analysis for each system is summarized in the following chapter, with specific topics explored in further detail in the Appendix.

- » **FABRIC:** Urban design, land use, and regulatory frameworks.
- » **PARKS:** Open space and environmental conditions.
- » **MOBILITY:** Transportation and access.
- » **ECONOMY:** Real estate inventory, incentive barriers, and market opportunities.
- » **CULTURE:** History, institutions, cultural assets, and higher education.
- » **OTHER THEMES:** Perceptions of Downtown, concerns about homelessness, and creating a unified message.

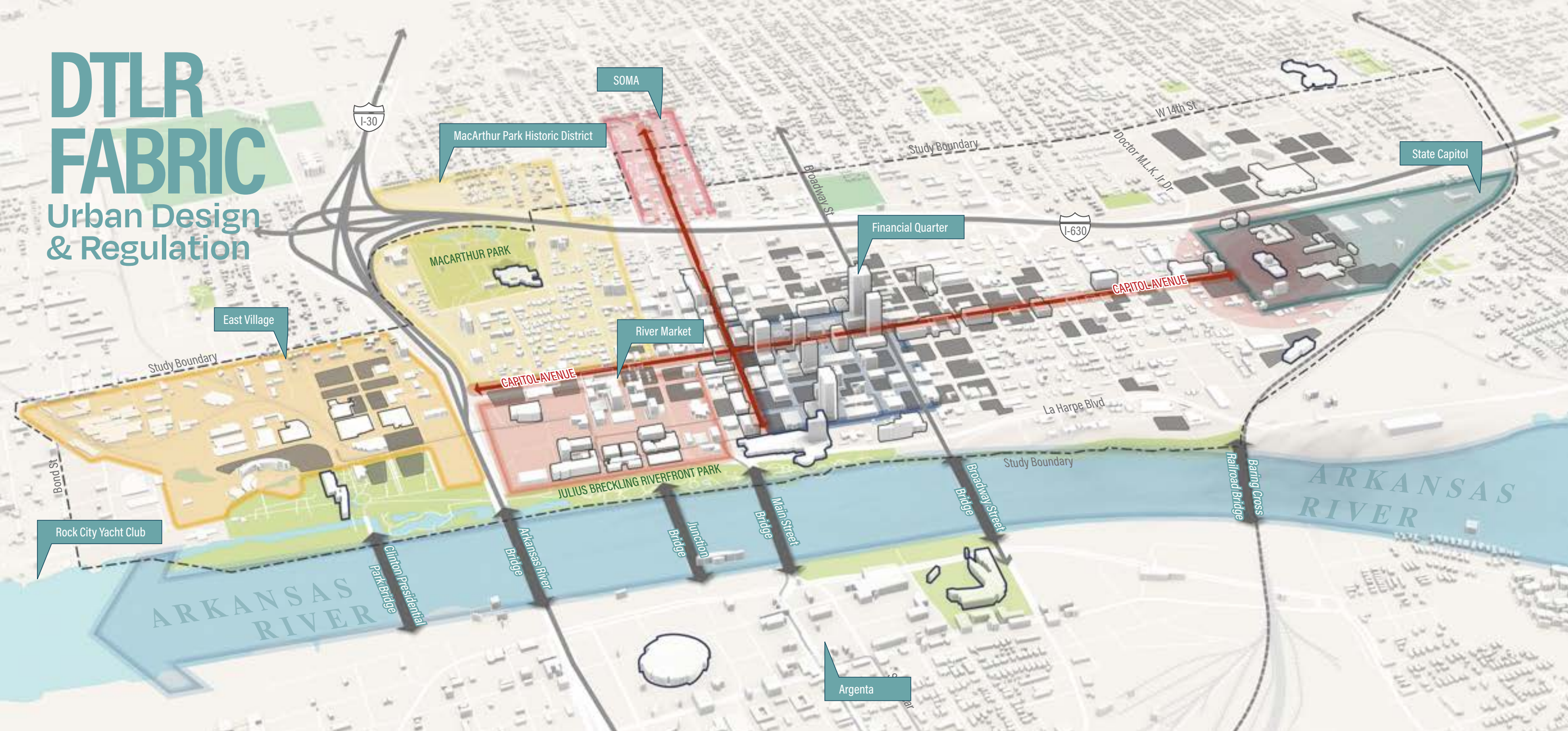
DTLR FABRIC

Urban Design & Regulation



-  Main Corridors
-  Bridges
-  Neighborhoods
-  Surface Parking



Downtown Little Rock is the oldest, densest, and most urban district in the entire State of Arkansas. As the seat of government, and the center of finance, healthcare, and other economic sectors for the State, the built form of the city has been shaped by its centrality and its position as a governmental center.

Main Street and Capitol Avenue are key thoroughfares whose intersection is the epicenter of Downtown. The Financial Quarter is home to the tallest buildings in the state, while different neighborhoods, including the River Market, East Quarter, the MacArthur Park Historic District, and SOMA are all unique in their history, character, and culture. The highly

regular and vast grid of 300' by 300' blocks makes the area one of the most interconnected and contiguous street grids in the Central US.

However, Downtown is littered with a sea of surface parking lots which detract from connectivity and walkability. It will be critical to build out from the areas with strong urban form and walkability, such as the River Market and Main Street, in order to create a more vibrant and connected downtown.

The urban form of Downtown has largely been shaped by various zoning regulations and other policies enacted over the course of the last 100 years. High parking requirements

for developers, which have since been waived, resulted in the demolition of much of the historic fabric for surface parking lots. Fire regulations, building height, and form restrictions have influenced how and what could be built – often at the detriment of denser, higher-quality development. Understanding the existing conditions and regulatory requirements helped to inform recommendations around zoning and land use outlined in the Implementation chapter.

DTLR FABRIC

Existing Regulation and Considerations

A Lack of Long-Range Planning

Little Rock is unique among many major cities in that it does not currently have, nor has ever had, a unifying comprehensive plan for the entire city. This has left a development guidance void for Downtown and other areas resulting in uncoordinated and piecemeal approaches to comprehensive planning and development across the city. Although the city does have an adopted future land use map, the lack of an overarching comprehensive plan and local area plans has generally led to an absence of long-range planning.

A Lack of Regional Coordination

Additionally, Little Rock, as the largest and most significant city in Central Arkansas, lacks broader regional coordination. Metroplan, the Central Arkansas metropolitan planning organization, has completed numerous urban design, mobility, transportation, and land use plans. These have often filled the void left by City of Little Rock and others. Such plans lie within Metroplan's scope as the primary facilitator of regional cooperation for transportation and land use planning. While the region has continued to invest heavily in roadways and commuting, Metroplan's efforts have informed various transportation projects and have helped steer some federal dollars toward active transportation improvements that benefit downtown. Little Rock must emphasize the importance of investing in active transportation and influencing land use decisions through infrastructure investments through its participation in Metroplan. Downtown Little Rock serves as the employment and cultural center of Central Arkansas. Surrounding communities have not always recognized that the success of downtown Little Rock is crucial to their own success. Central Arkansas needs a stronger sense of regional identity. Downtown's future success will depend not just on local residents, but also on regional commuters from surrounding communities valuing and promoting investment in downtown Little Rock. This has led to a cannibalization effect that has left the region weaker than many of its competitors.

A Lack of Economic Development Guidance

Unlike most cities, Little Rock lacks any formal Office of Economic Development within City Hall. Typically, these offices are utilized to promote business retention and recruitment, facilitate programs related to workforce development, and promote development incentives such as TIF and tax abatements to encourage new development. This ecosystem is entirely absent at the city level, resulting in a lack of potential tools, strategies, and implementation devices to better enable the City and Downtown to thrive. The Little Rock Chamber of Commerce serves as the de facto economic development organization promoting business within the City, although their capacity does not extend to financial tools and incentives.

Other Coordinators and Entities

There are numerous other nonprofits and organizations that work in various capacities to promote better planning and development in Downtown. The Downtown Little Rock Partnership oversees the Metrocenter Business Improvement District and serves as the coordinator for programming and events within Downtown. Within their work, they often serve as an economic development engineer for Downtown by promoting local businesses. StudioMAIN is a 501c3 nonprofit organization that aims to promote urban design and placemaking within the City of Little Rock. They host various design competitions and tactical urbanism events that aim to increase the capacity of city leaders and the design community.



A Concentrated Dense Core

While there are numerous tall towers in Downtown, most are concentrated north of W 7th Street and east of Broadway Avenue. The Financial Quarter & River Market are the densest neighborhoods.



A Sea of Parking

One of Downtown's most significant urban design challenges is the large number of surface parking lots & garages, which increase urban heat island while also reducing walkability and perceptions of safety. There are an estimated 46,000 parking spaces downtown, which is more than one space for every resident and worker combined.



Underdeveloped Properties

Although there are concentrations of higher density areas and parcels with high lot coverage, much of Downtown is made up of underdeveloped properties. Areas with a Floor-Area-Ratio (FAR) of 0.5 or less, which include vacant lands and surface parking lots, do not provide the best and highest use in an area of high land values.

DTLR LAND USE

Current Conditions

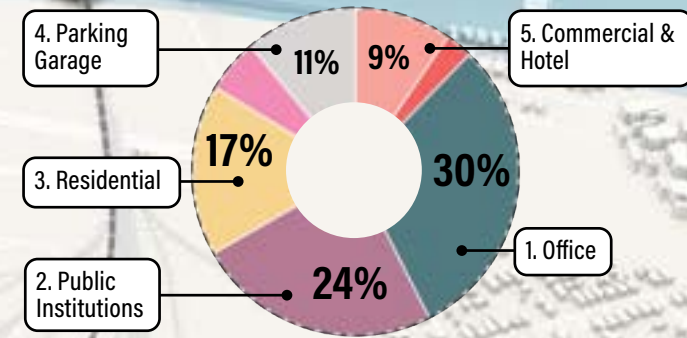

Building Use

- Mixed Use (3% of Downtown Study Boundary)
 - Commercial / Hotel (9%)
 - Office (30%)
 - Public Institutions (24%)
 - Residential (17%)
 - Industrial (1%)
 - Parking Garage (11%)
- Main Corridors
 - Bridges
 - Surface Parking

Current Land Use

Downtown Little Rock has a high mix of land uses scattered throughout the 2.5 square mile area, although many are still highly segregated due to zoning and other regulations. The eastern side of Downtown near East Village is the only area with industrial uses still remaining. That said, there is an emerging mixed-use neighborhood developing in the area, including residential, office, and retail uses. The core of Downtown, including the River Market, Main Street, the Financial Quarter and areas west of Broadway are a mixture of residential, office, hospitality, and other commercial uses. Although newer buildings in the River Market and renovated historic buildings along Main

Street contain an integrated mixture of uses within single buildings, most buildings remain single land uses. This area also contains the highest amount of vacant land due to surface parking lots. South of Downtown, the SOMA neighborhood has begun to emerge as a vibrant mixed-use district, with a variety of commercial and residential options centered along Main Street south of I-630. The remainder of Downtown is a ring of largely single-family and lower-density residential neighborhoods, including the MacArthur Park Historic District, Pettaway, the Governor's Mansion Historic District, Dunbar, and Central High neighborhoods.

Overall Downtown comprises 11.4 million square feet of office space, 2.0 million square feet of retail, 1,913 multifamily rental housing units, and 2,177 hotel rooms. Most notably, over 10% of Downtown's land area is dedicated to surface parking lots - the most prevailing land use (SB Friedman Development Advisors, LLC).

DTLR LAND USE

Future Land Use

Future Land Use

Although Little Rock lacks a comprehensive plan for the city, the City does have an adopted future land use plan that can serve as the starting point for long-range planning in the Downtown area.

The Future Land Use Map, last updated and approved by the City Board of Directors and City Planning Commission in 2022, informs zoning decisions made by the Planning Commission. There are a total of 20 land use categories shown on the Future Land Use Map, including five mixed use categories, four residential, two office, two industrial, two commercial, an agricultural, a mining,

parks and open space, a public institutional, and a transition category.

Downtown is composed largely of "Mixed Urban Use", which "provides for a mix of residential, office and commercial uses not only in the same block but also within the same structure. This category is intended for older urban areas to allow dissimilar uses to exist, which support each other to create a vital area. Development should reinforce the urban fabric creating a 24-hour activity area."

Other predominant future land uses include Public Institutions (including the State Capitol Grounds and Arkansas Children's Hospital), Medium Density Residential such as the MacArthur Park Historic District, and Low Density Residential such as the Central High and Dunbar neighborhoods.

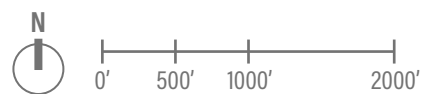
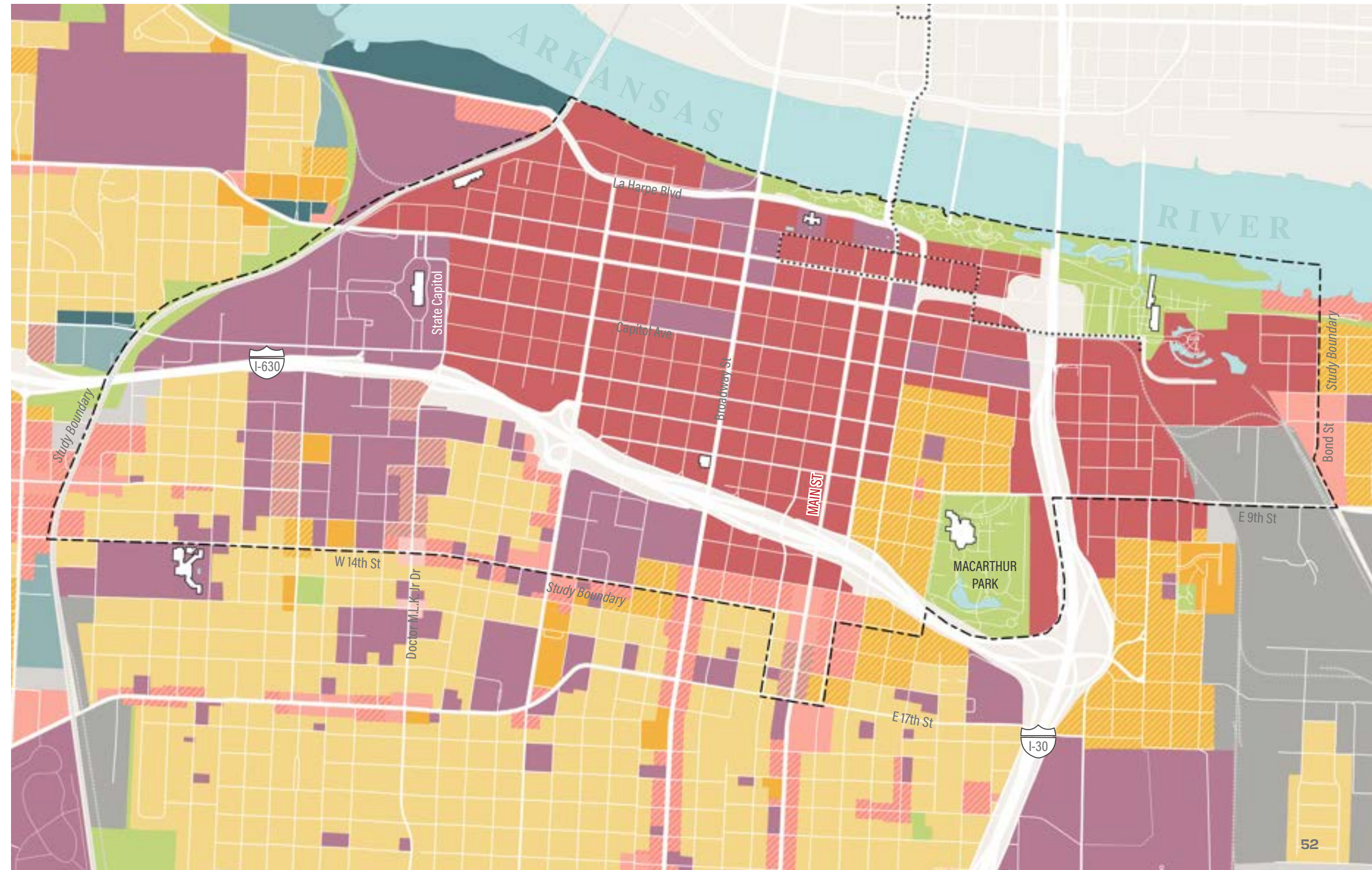
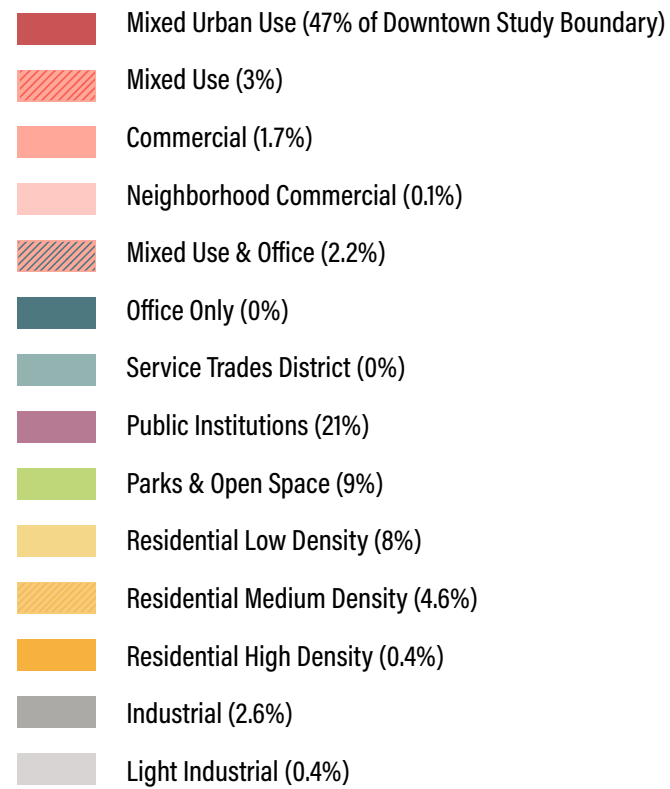

DTLR LAND USE Zoning

- Urban Use
- Parks & Recreation
- Open Space
- COMMERCIAL**
- C4 "Open Display Commercial"
- C3 "General Commercial"
- Neighborhood Commercial
- OFFICE**
- Office & Institutional
- O3 "General Office"
- O1 "Quiet Office"
- MULTIFAMILY RESIDENTIAL**
- R6 (High-Rise)
- R5 (Urban Residence)
- MF24 (units/acre)
- MF18 (units/acre)
- INDUSTRIAL**
- I2 Light Industrial
- I3 Heavy Industrial
- SINGLE FAMILY RESIDENTIAL**
- R2 (Single-Family I)
- R3 (Single-Family II)
- R4 (Duplex I)
- R4A (Duplex II)
- PLANNED DISTRICTS**
- Commercial
- Office
- Residential
- Industrial
- PLANNED DEVELOPMENTS**
- Commercial
- Office
- Residential
- Industrial
- CAPITOL ZONING DISTRICT**
- Zone A "State Capitol Foreground"
- Zone B "Capitol Area Residential"
- Zone C "Union Station Mixed Use"
- Zone D "Interstate Industrial"
- Zone E "State Capitol Complex"
- Zone M "Mansion Area Residential"
- Zone N "Neighborhood Commercial"
- Zone O "General Commercial"
- Design Overlay District
- Capitol Zoning District
- Study Boundary

Current Zoning

The 2.5 square mile study area comprises numerous different zoning categories, ranging from Little Rock's most intense and dense Urban Use (UU) to single-family zoning districts such as R2 and R3. The area is also regulated by the State's Capitol Zoning District.

UU covers the majority of Downtown, from Cross Street on the west to Bond Street on the east. The district permits 72' in height by right, with up to 225' if various considerations are made. This district also permits most land uses. Notably, this district also

does not require additional off-street parking. Other notable zoning areas include R2, R3, R4, R4A, Planned Office Districts, and C3 (General Commercial).

Downtown is also composed of various design overlay districts, including the River Market Overlay District, Presidential Park Overlay District, Central City Overlay District, the Central High Overlay District, and the MacArthur Park Historic District, which all regulate building design and form in various capacities.

It is worth noting that, due to the large size of UU zoning, there is an abrupt transition from the City's most intensive zoning to single-family residential, which has led to the awkward and disconnected nature of surrounding neighborhoods to the urban core, including the dense urban fabric being surrounded by a ring of low density commercial uses and surface parking lots.

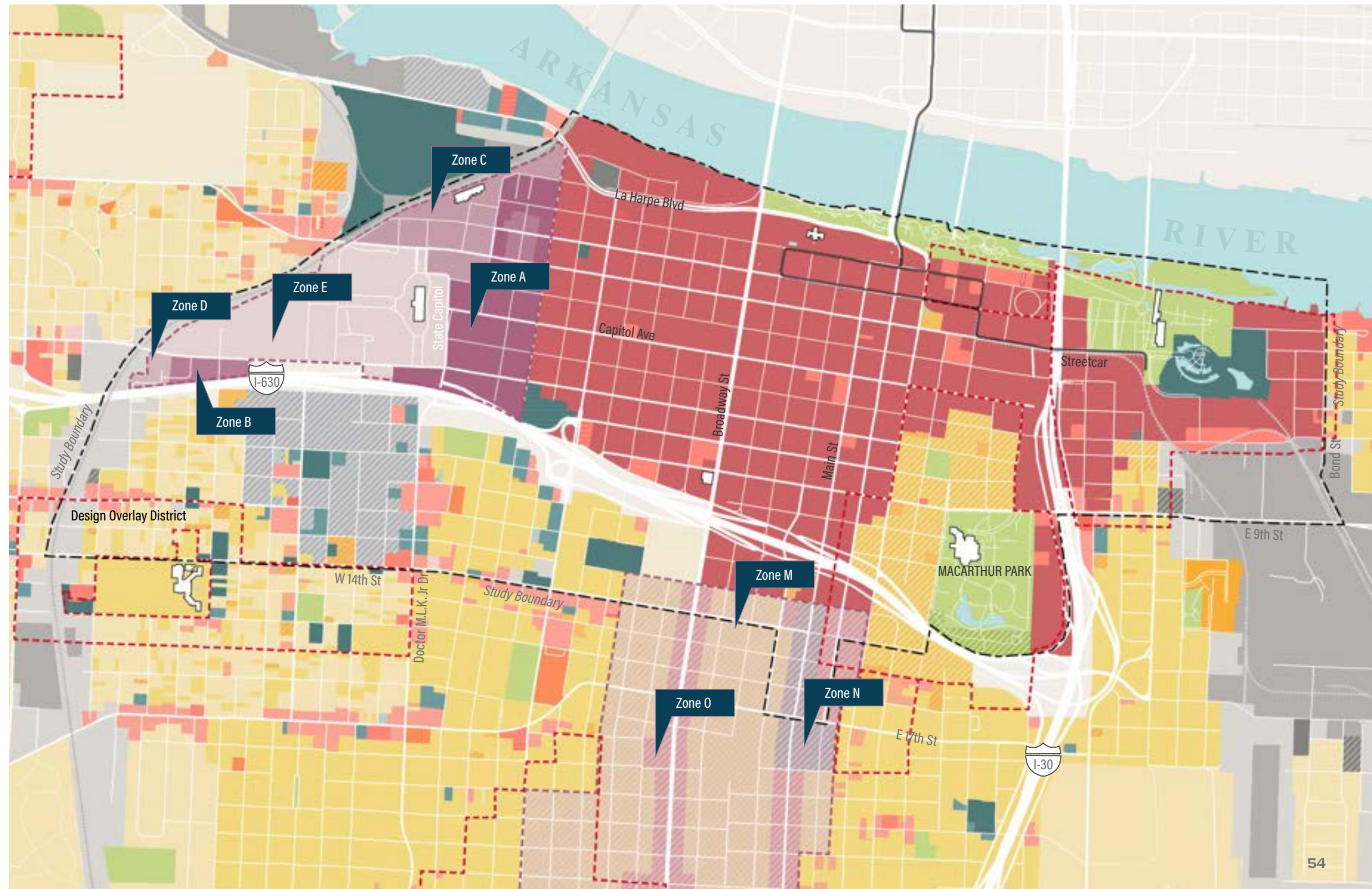

DTLR FABRIC

Regulatory Barriers

Fire Codes

Large portions of Downtown Little Rock are included in the downtown fire district — one of three areas of the city regulated by a fire district as specified in the City's code. This fire district requires a 200 foot buffer around the district to prevent the spread of fire. Through numerous conversations with developers, the fire district was identified as a code ordinance that has made new development, including the development of international building code-permitted building types, difficult or prohibited. Through modern sprinkler and fire suppression systems, the need for fire districts is an antiquated building code practice which should be removed from the City's code. Other fire codes were also noted as barriers for infill development and should be explored for modification to more easily encourage new development.

Capitol Zoning District

Downtown Little Rock is unique in that portions of the area, including around the State Capitol and the Governor's Mansion, are regulated by the State of Arkansas. The Capitol Zoning District Commission, managed by the Arkansas Historic Preservation program within the Arkansas Heritage Division, utilizes state-adopted zoning to regulate the design and preservation of neighborhoods around key state-owned assets. While this has resulted in higher-quality design, it has also added an additional complex step to planning and development in these areas. This, combined with antiquated ordinances and codes within the Capitol Zoning District and a lack of coordination between the State and the City, has disincentivized substantial new development in these areas. Changes to the Capitol Zoning District code are needed if new development is expected in these areas.

Urban Use (UU) Zoning

Urban Use (UU) zoning in the heart of Downtown enables buildings to be 72' in height by-right. That said, development can achieve up to 225' in height through providing a vertical mixture of uses, including retail, office, and residential, ground-level entries, and bus shelters or other transit provisions. Due to the complexity of financing and developing multiple uses within a single building, very few new developments have exceeded this building height since the code has changed. The Downtown Density Taskforce is considering amending the UU ordinance to better function for development.

Platting

Current platting requirements in the city disincentivize infill development and they encourage de-densification of neighborhoods. The current code allows a property owner of multiple contiguous properties to replat those parcels into a single, larger parcel through simple permitting and without neighbor permission. This enables the construction of much larger homes, so long as it is a single residential unit. On the other hand, the current code requires neighborhood approval for subdividing a residential parcel into multiple smaller parcels, meaning that it is prohibitively more difficult to add density to existing neighborhood fabric.

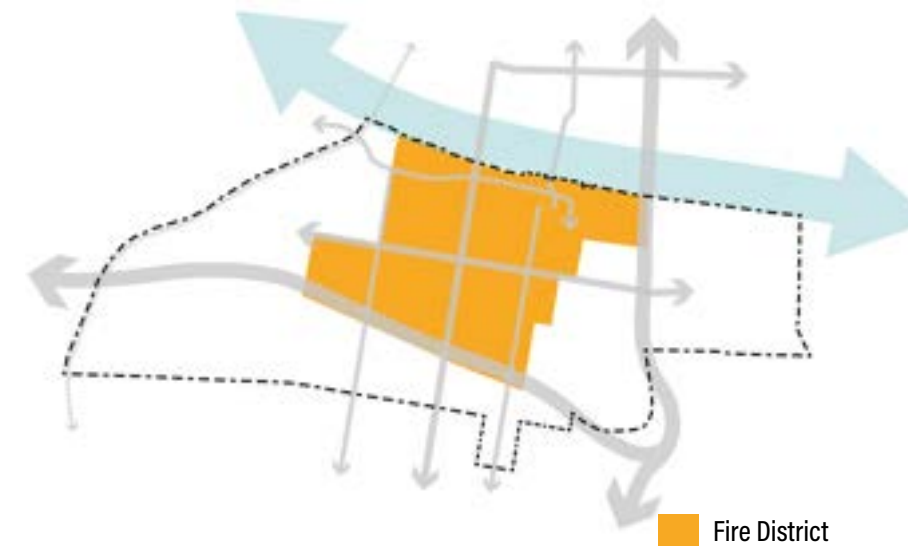

Fire District

This fire district requires a 200 foot buffer around the district to prevent the spread of fire. This fire district was identified as a code ordinance that has made new development, including the development of international building code-permitted building types, difficult or prohibited and should be amended.

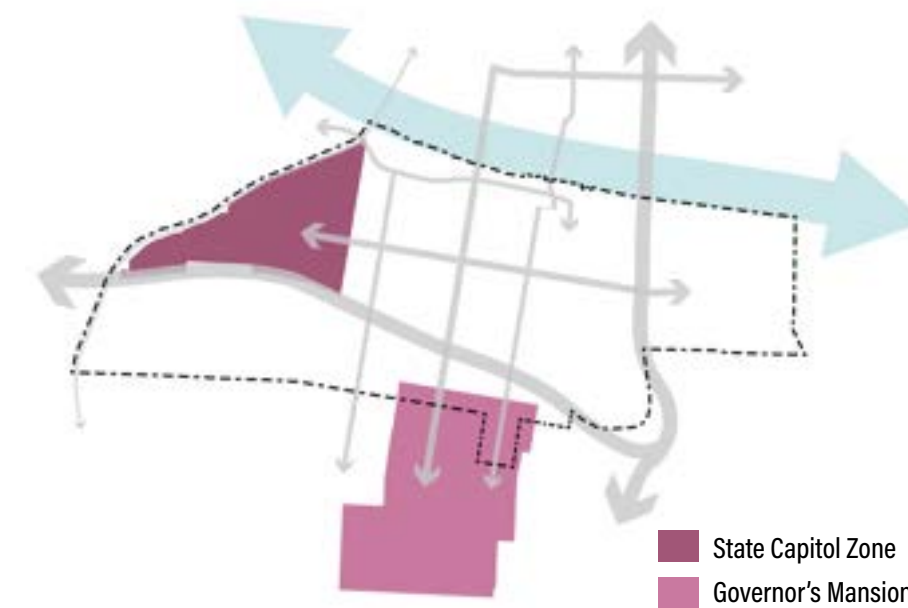

Capitol District

The Capitol Zoning District includes land around the State Capitol and Governor's Mansion. While the code regulates the design and preservation of neighborhoods around key state-owned assets, it also often disincentivizes new development due to prohibited land uses.

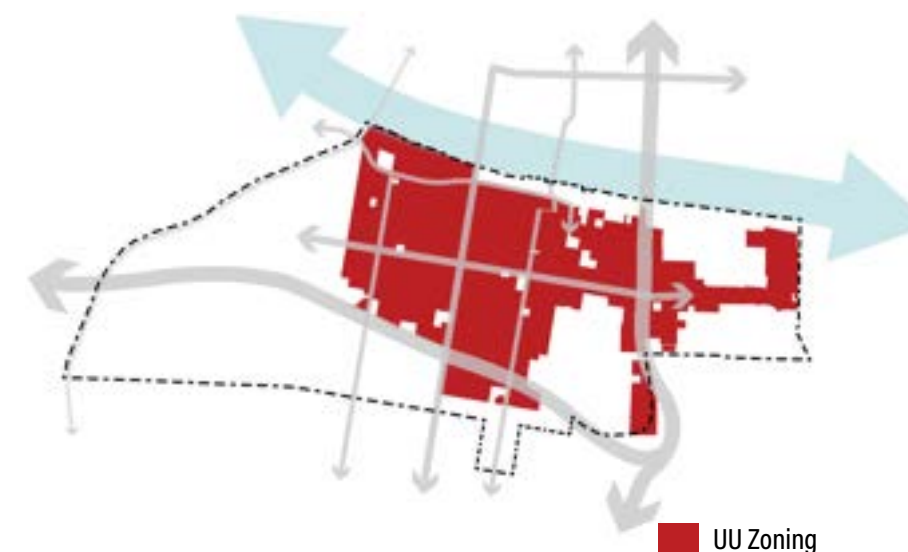

UU Zoning

Within the UU Zoning District, buildings can reach up to 225' only if they provide a vertical mixture of uses. The complexity of this requirement results in buildings heights often capping at the max single-use height of 72'. Amending the ordinance would make development over six stories easier to deliver.

DTLR FABRIC

Metrics & Benchmarking

Downtown Little Rock lags behind many other peer cities in creating a dense and active urban core. Fundamental to that is creating a healthy residential population that supports retail and enhances the sense of vitality in the evenings and on the weekend. Downtown Little Rock has roughly half the population density of its next closest peer, Des Moines, and has roughly a quarter the population density of fellow Southern capital cities of Richmond, Virginia and Raleigh, North Carolina.

How does Little Rock Compare?

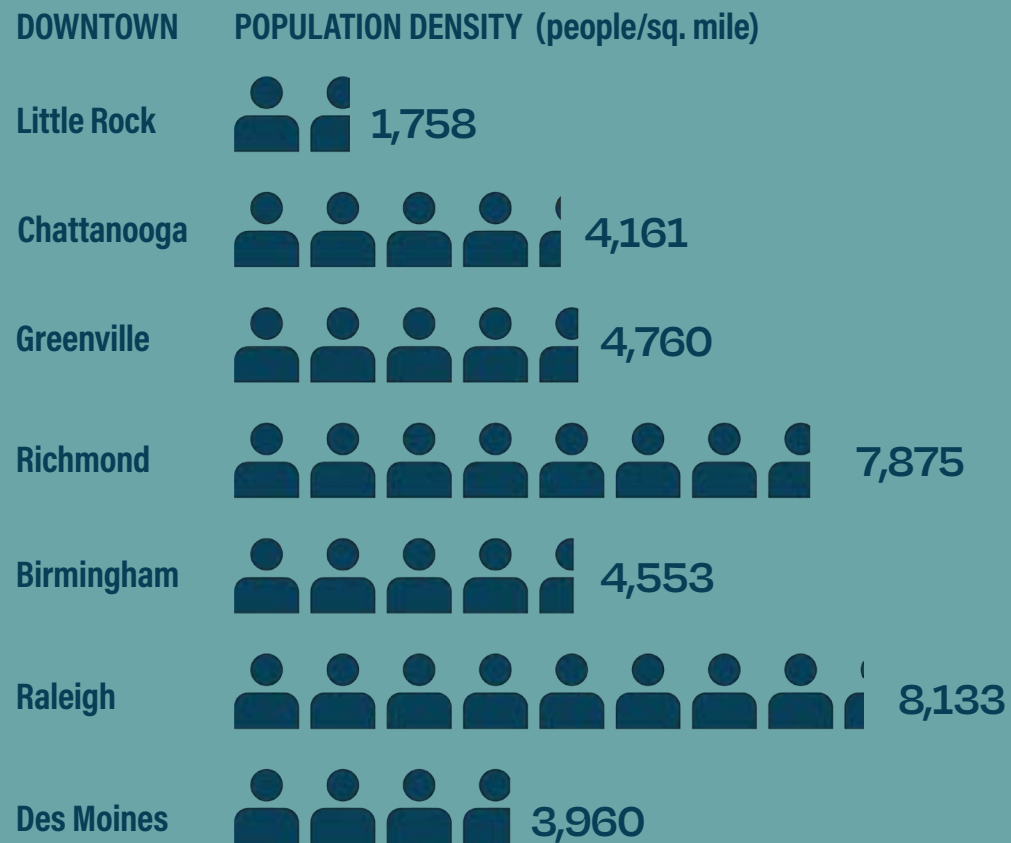

Source: SB Friedman Development Advisors, LLC

WHAT WE HEARD

Residents of Little Rock desire downtown to be an active neighborhood. Reimagining Downtown as a liveable neighborhood that is desirable for all ages and family types will require there to be housing choices, neighborhood amenities such as parks and playgrounds, and daily needs retail to make it a distinct that is accommodating for living, working, and visiting.



Survey 1 Feedback on Downtown Fabric

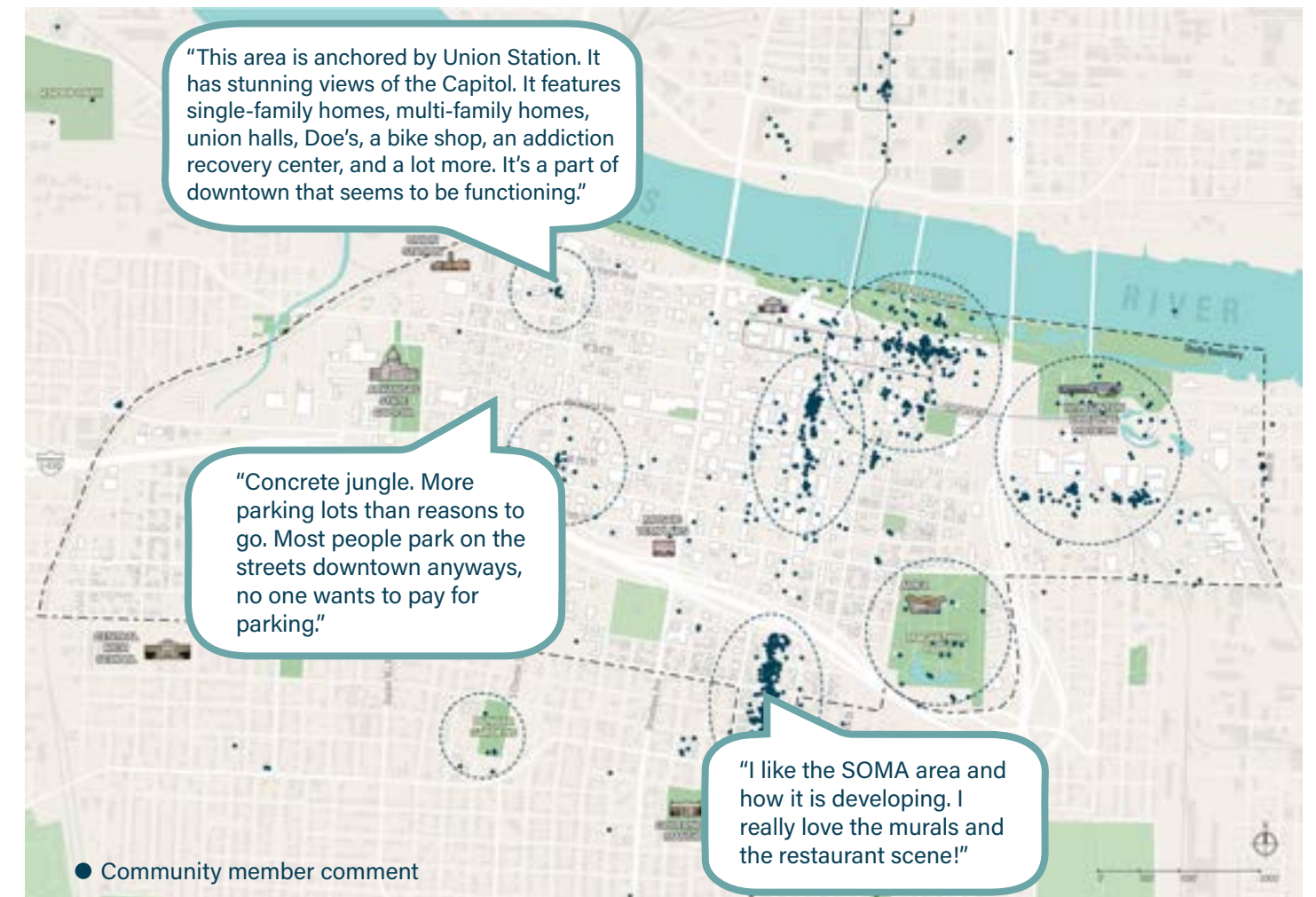



WHAT WE HEARD

1



A lack of long-range planning is resulting in a lack of unified vision and coordination across city, regional, and state planning efforts, leading to reactive instead of proactive planning.

2



A lack of institutionalized economic development tools and an Economic Development Department is hindering new development and the retention of existing employers in Downtown.

3

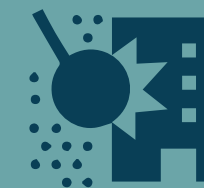

A lack of regulation around the demolition of existing structures and the permissibility of constructing new surface parking lots, has resulted in surface parking being one of the prevailing land uses in Downtown.

4



Regulatory barriers within city and state zoning are disincentivizing new development downtown due to complex approvals processes and antiquated development code policies.

5



The lack of existing residential development has resulted in a lifeless downtown that has perpetuated perceptions of the area being unsafe while also disincentivizing new retail and residential construction.

DTLR PARKS

Open Space & Environment

- ① Knoop Park
- ② Junior Deputy Baseball Park
- ③ Fletcher Park
- ④ Centennial Park
- ⑤ Barton Park
- ⑥ Dunbar Park
- ⑦ W. E. Clark Presidential Park Wetlands
- ⑧ Hangar Hill Park
- ⑨ Pettaway Park
- ⑩ Oakland & Fraternal Historic Cemetery Park

- City-Owned Public Open Space
- Other Public Open Space
- Private Open Space
- Cemetery
- Future Open Space

- Multi-Use Trail
- Proposed Multi-Use Trail
- Kayak Trail
- Playground
- 5 Minute Walk Zone
- 100 Year Flood Zone
- 200 Year Flood Zone

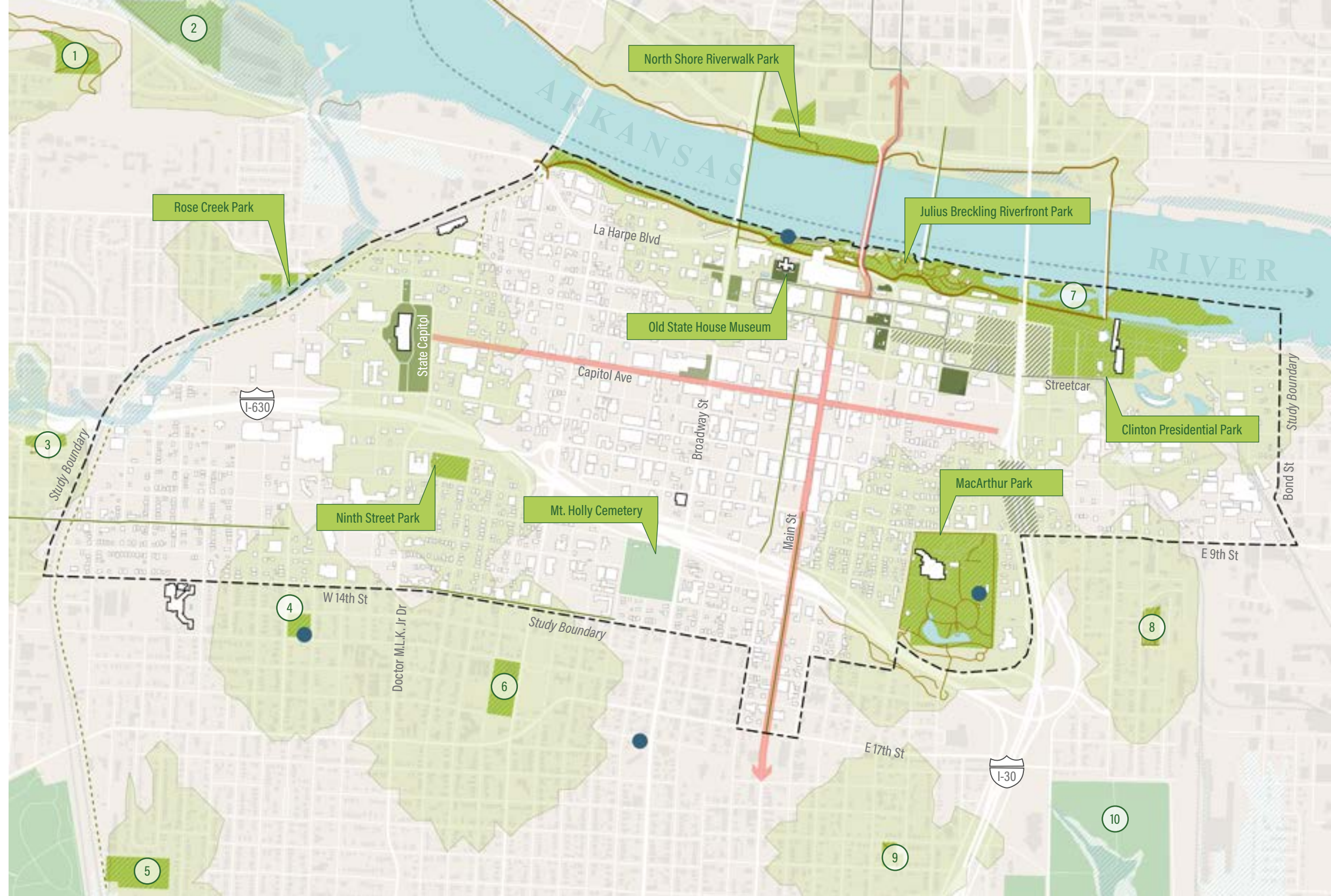

Downtown Little Rock is defined by the Arkansas River. Although it only shapes one side of the district, the river is the city's historic life blood and its greatest natural asset. Enhancing connectivity and celebrating the river is essential for improving quality of life downtown and connecting the district to other neighborhoods.

MacArthur Park, historically City Park, is home to the Arkansas Museum of Fine Arts and the MacArthur Museum of Arkansas Military History, and is another open space gem that can be an enhanced recreational heart of downtown life. Although the park

has new playground and dog park enhancements, further improvements and improved accessibility could reinforce this as a great community park.

Even with these two open space assets, the majority of Downtown is lacking in quality green spaces and access to nature. Much of the central and western portions of Downtown are more than a 10-minute walk (1/2 mile) from any open space. Creating new open space connections, new parks and trails, celebrating the unique ecology of

Central Arkansas, while enhancing the tree canopy, are all opportunities that can be explored through this plan.



DTLR PARKS

Existing Systems Overview

Park and Trail Operations

Currently, the various City of Little Rock-owned park and open space assets are managed by the City's Parks and Recreation and Public Works departments, along with assistance from others, including the Downtown Little Rock Partnership. Parks are largely overseen by the Parks Departments whereas trails are overseen by Public Works, even within Park property. This is an unusual and potential problematic management structure that can lead to conflicting design outcomes and undesired consequences.

Critical to open space enhancements in Downtown Little Rock will be identifying and successfully completing missing trail segments, such as the missing segment of the Arkansas River Trail near the Dillard's Corporate Headquarters. Having one central department responsible for the operations, maintenance, and construction of all parks and trails is essential for creating a highly functional and effective parks and trail system.

State Capitol Grounds

The Arkansas State Capitol sits proudly on a hill on the western side of Downtown. And while the prominent building's front lawn and facade carry the traditional significance expected with a center of government, the remainder of the State Capitol Grounds are largely underutilized properties with great potential. The western side of the Capitol Grounds drop towards the Union Pacific Railroad and the Rose Creek Greenway which lies on the west side of the tracks. This area is largely vacant land or surface parking lots. Given the general lack of open space on the western side of Downtown, the significance of the Capitol itself, and with the proposed Rose Creek Greenway and Southwest Trail slated to run along the western edge, the Capitol Grounds present a wonderful opportunity to reimagine portions of the grounds to celebrate the State Capitol and provide open space amenities for the district.

New Park Opportunities

The reconstruction of I-30, slated for completion in 2025, has enabled two potential new open space opportunities which, if completed, could be significant additions to Downtown and the region.

The removal of a series of off-ramps in the River Market District has freed up 18 acres of land. This land was discussed as a part of the highway construction project as potential new open space which could better connect the River Market District with East Village and the Clinton Library.

Additionally, as a part of the reconstruction of I-30, the portion between 6th Street and 9th Street was designed with the ability to accommodate a future deck park. The City of Little Rock received a \$2 Million planning grant from the US Department of Transportation to study the feasibility and design options for a new deck park in this location. This potential new connection would serve to better connect East Village with MacArthur Park and the Arkansas Museum of Fine Arts.



The Crossroads of Arkansas Ecology

Downtown Little Rock is where many unique Arkansas ecosystems converge. This crossroads, where Ouachita Mountains meets the delta, should celebrate its distinct location within The Natural State through placemaking and park design.



Parks On The Periphery

Most of Downtown's public open spaces are located along the perimeter — including the along the Arkansas River, leaving the heart of Downtown without adequate access to quality outdoor spaces.

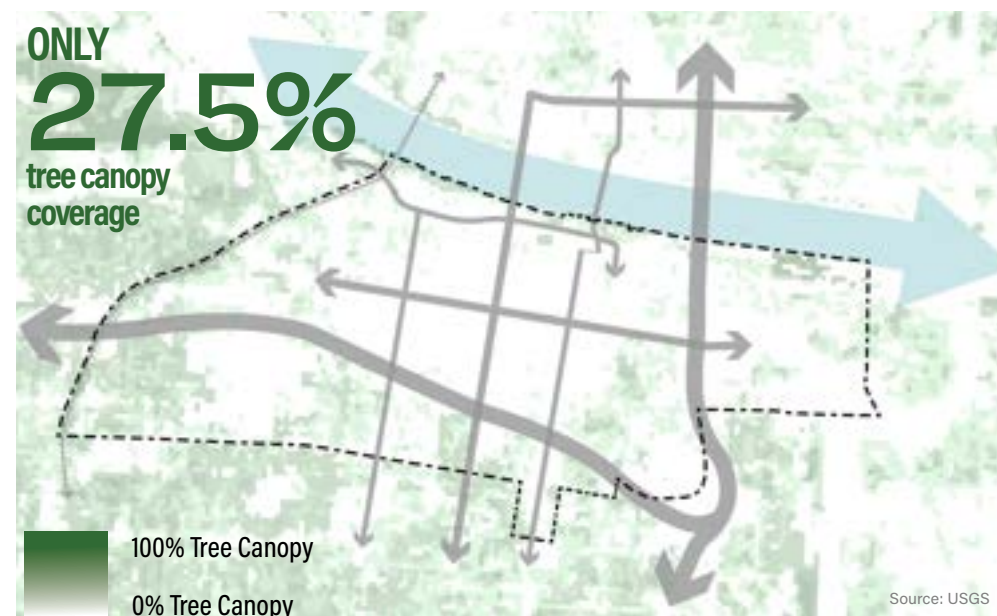

An Absence Of Tree Canopy Downtown

While the city of Little Rock has 48% tree canopy, Downtown only has 27.5%. Trees remove air pollutants, filter stormwater, cool hot city streets, aid in placemaking, and strengthen urban habitats.

DTLR PARKS

Metrics & Benchmarking

Compared to similar cities such as Greenville and Richmond, Little Rock has a higher percentage of downtown acreage that is dedicated to park space.

The undeveloped land near the River Market where the I-30 clover leaves once resided offers a unique opportunity to even further expand the downtown park land. If all 18-acres were dedicated to park space, that would push Little Rock's percentage of park land downtown significantly beyond that of comparable cities therefore multiple alternatives should be explored.

How does Little Rock Compare?

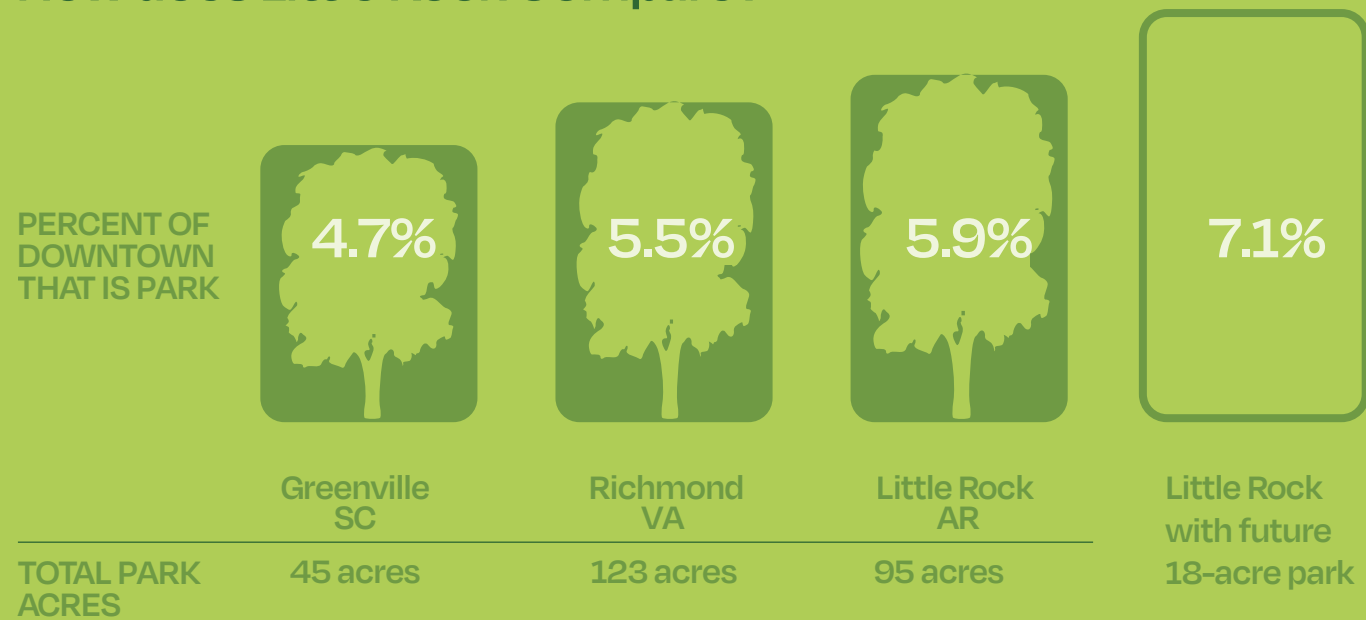

Downtown Greenville, SC



Downtown Richmond, VA

WHAT WE HEARD

Downtown Little Rock is the heart of the City, and its location along the Arkansas River gives it the potential to be the epicenter for outdoor recreation for residents as well. That said, the district currently lacks functional open space that enables high quality of life and opportunities for residents, workers, and visitors.

Residents desire improvements to existing parks to improve their day-to-day recreational experiences, including the desire for new playgrounds, dog parks, and trails for outdoor leisure. Additionally, there are areas within Downtown that are entirely lacking green space. There is a desire for these empty areas to provide more daily-use outdoor areas that will improve their quality of life. Lastly, there is a desire for there to be more trail connectivity on proposed trails and enhanced connections to the Arkansas River Trail. The Arkansas River should be the centerpiece of outdoor spaces for the City and yet is difficult to access. Improving multimodal access for all Downtown neighborhoods is critical to ensuring improved recreation opportunities for residents and workers.

Survey 1 Feedback On Open Space





WHAT WE HEARD

1



The Arkansas River is a tremendous open space asset that is underutilized. Future investments should prioritize additional access and reimagined adjacent land uses to better engage with the waterfront.

2



Downtown has ample park land, but there are large areas lacking adequate green space. There should be a tactical approach that includes enhancing existing assets and reimagining vacant land and public right of ways to function as green space.

3



The removal of the I-30 off-ramps in the River Market area are a once-in-a-lifetime opportunity to create a central public open space in the heart of a thriving district.

4



The State Capitol grounds have the opportunity to be the nexus of an interconnected trail network. Efforts should be made to reimagine portions of the grounds to celebrate the significance of the site, connect to future trails, and provide open space to the west side of Downtown.











5



Future open space and infrastructure investments should prioritize sustainability, resilience, and improving environmental quality through green infrastructure, enhanced tree canopy, and ecological restoration and enhancements.

DTLR MOBILITY

Transportation & Accessibility

-  Highway
-  AMTRAK rail
-  Freight rail
-  Bus Route
-  Streetcar
-  Existing Multi-Use Trails
-  Proposed Multi-Use Trails
-  Pedestrian Bridge
-  Bike Lanes
-  District Gateways

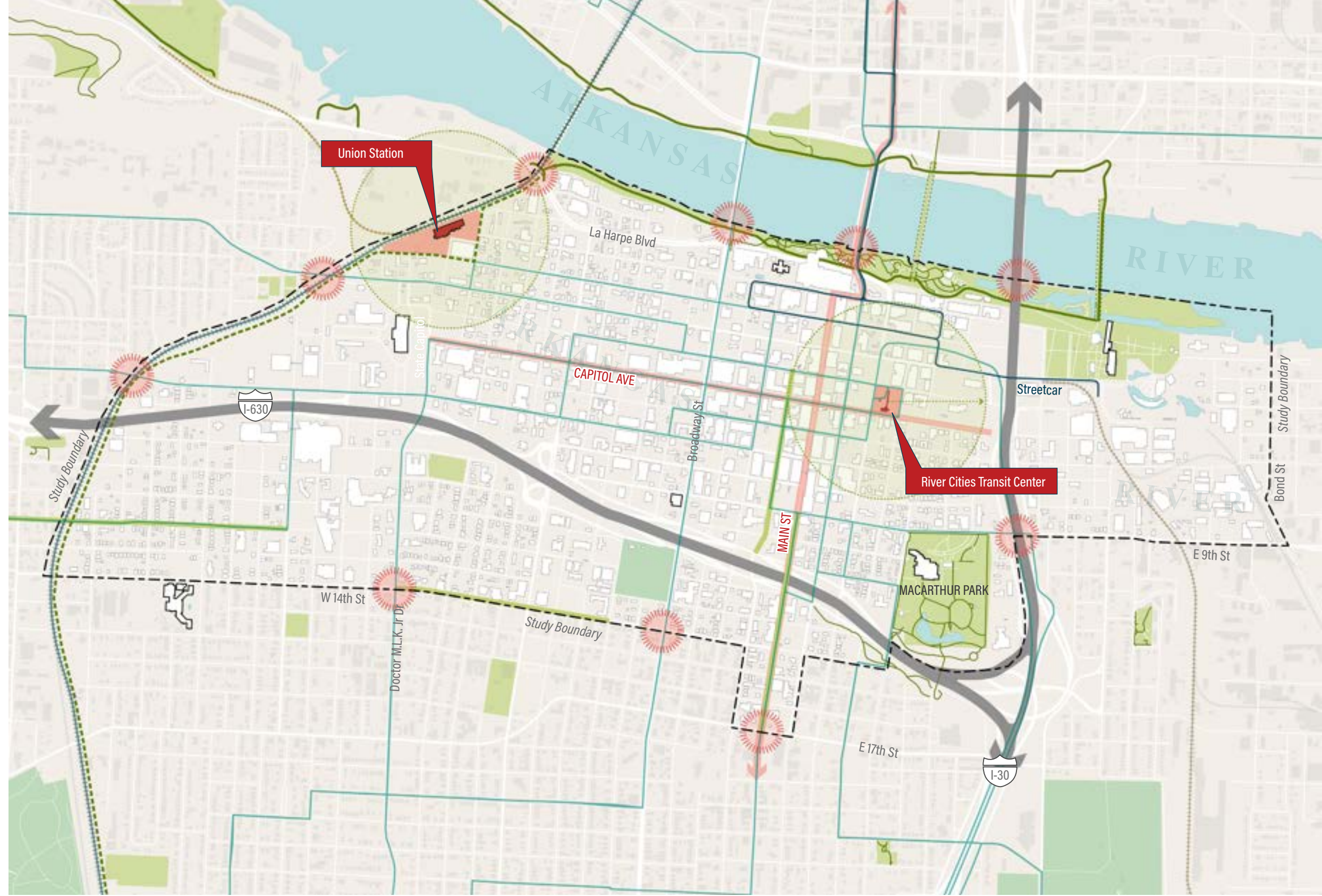

Downtown Little Rock provides all forms of mobility, including multimodal trails, streetcar, bus, Amtrak, and interstate highways. These modes make the area one of the most accessible areas of the region, but also creates barriers. The highways, railways, and Arkansas River create limited points of access into the district, meaning improving connectivity at key points will be critical to enhancing the role of the District in daily life. Just as important is improving connections across the Arkansas River to North Little

Rock, as success in Argenta and Downtown Little Rock stands only to benefits both sides of the River The River Cities Transit Center is an opportunity for increased connectivity, where all of Rock Region Metro's transit converges. This full-city block can serve as a transit-oriented node for the surrounding area, including the River Market, Main Street, and the MacArthur Park Historic District. Existing and proposed trail connections also present opportunities for

enhanced connectivity to the urban core from the rest of the region. Completion of the Arkansas River Trail, along with the proposed Southwest Trail, Southeast Trail, and Rose Creek Greenway, will reinforce Downtown as the nexus of transit and multimobility in Central Arkansas.



DTLR MOBILITY

Existing System Themes

The Nexus for Rock Region Metro

Rock Region Metro is Central Arkansas' only public transit provider and is the largest transit provider in Arkansas. The service operates dozens of bus routes and manages the Metro Streetcar connecting Downtown Little Rock to Downtown North Little Rock. Many of these bus routes and the streetcar converge at the River Cities Transit Center in Downtown Little Rock at 4th and Cumberland. This provides direct transit access to numerous points in the region.

Although Downtown has the highest transit frequency and best transit coverage, bus headways are still often 30 minutes or greater, and operating hours are limited due to financial constraints after ridership has dropped since the COVID pandemic. Additionally, the streetcar moves slowly and does not connect to major employment or residential areas, meaning ridership is largely catering towards tourists.

Reimagining how the transportation system moving into and through Downtown can help to improve its viability and reliability, providing additional mobility options, reducing the need for private vehicle use, and reducing parking demand in the process.

Reimagining the transportation system and how it moves into and through Downtown can help to improve its viability and reliability. This could provide additional mobility options, reducing the need for private vehicle use, and reducing parking demand in the process.

Enabled and Fragmented by Highways

Downtown Little Rock, with 17% of the region's jobs, lies at the very heart of Central Arkansas and is highly connected to the rest of the City and region via Interstate 630 and Interstate 30. While these freeways have enabled the City's growth and success as a regional job center, they have also reinforced urban sprawl and the decline of the district as a

residential neighborhood by enabling fast, easy access to cheaper land and alternative neighborhoods. Furthermore, their construction severed the core of downtown from the surrounding neighborhood fabric, while also destroying entire neighborhoods in the process. The West Ninth Street District, Little Rock's historic Black Main Street, was largely destroyed through the construction of I-630 in the 1970's and 1980's. The demolition of neighborhood fabric created trauma and distrust among Communities of Color in Little Rock that remains to this day.

The combination of racial segregation practices such as redlining, the impacts of desegregation within the Little Rock School District, with the construction of I-630 isolated many of these neighborhoods from economic development and growth, leading to a great disparity in socioeconomic conditions, health, and quality of life outcomes for their residents. The effects of these impacts have resulted in depressed and blighted neighborhoods in areas south of Downtown, with higher crime, high vacancy, and lower property values that have reinforced negative perceptions of Downtown Little Rock.

A Potential Hub for Regional Trails

As the heart of Central Arkansas, Downtown Little Rock is well positioned to become the center of multimodal mobility. In 2023, Metroplan announced the Central Arkansas Regional Greenway Master Plan, which aims to construct a 220-mile interconnected trail network which will all converge in and around Downtown Little Rock. This trail network, which uses the existing Arkansas River Trail and proposed Southwest Trail as two key spines, will enhance regional mobility while also driving economic development along the routes.

Critical to this is the completion of missing trail segments, including the missing connection on the Arkansas River Trail near the Dillard's Corporate Headquarters. Building this missing link should be prioritized above all other construction as it will ensure a singular, interconnected network.

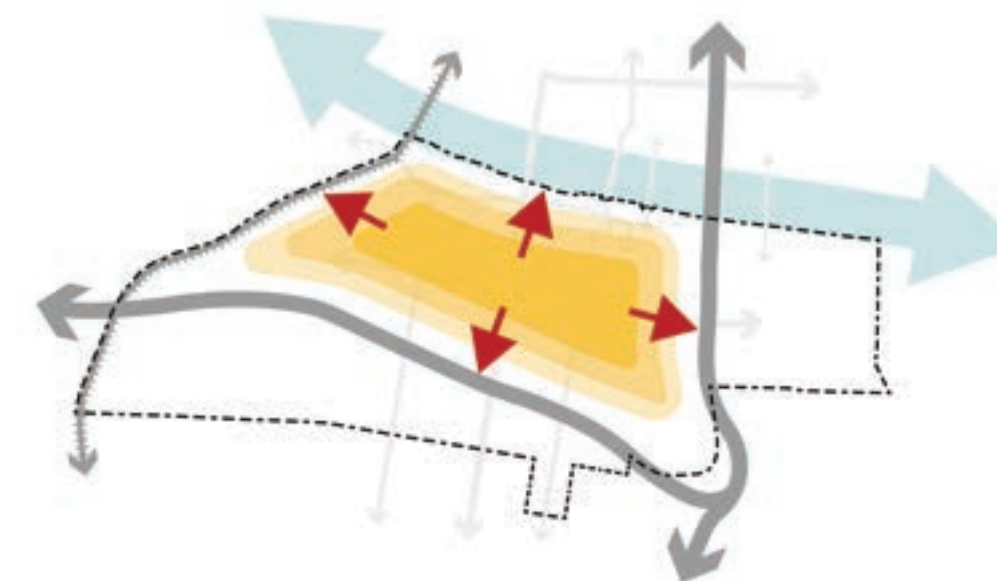
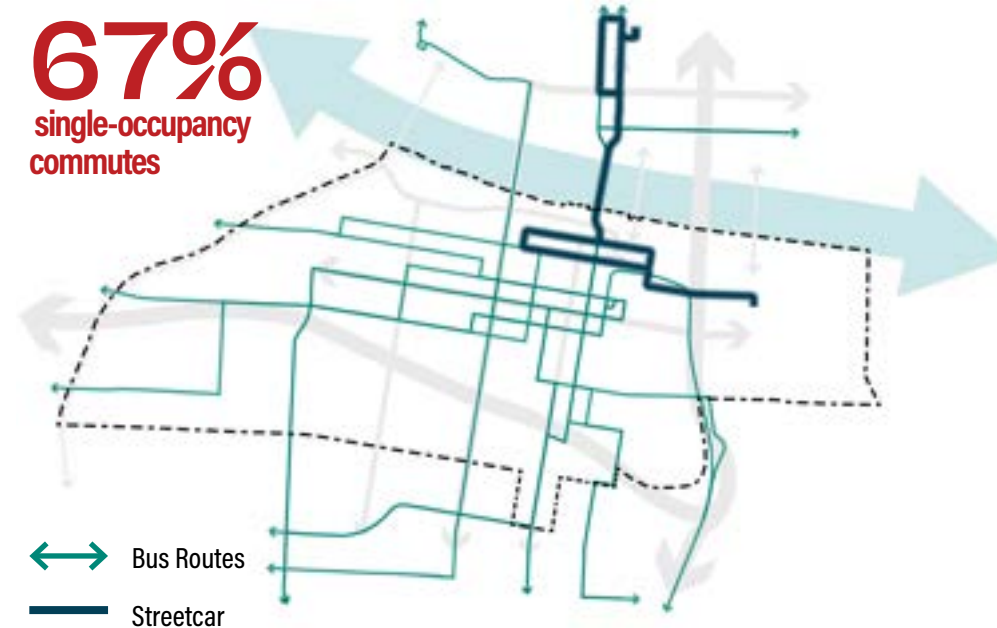

Little Rock is Auto-centric

Downtown receives over 30,000 daily commuters. Although Rock Region Metro services the area with 8 bus routes and a streetcar service, transit accounts for only 5% of daily work commuter trips.

A Lack of Micromobility

Although better than most other areas of Central Arkansas, Downtown's micromobility connectivity needs improvement compared to other peer cities. There are limited bike lanes, and trail connectivity should be enhanced.

Physical Barriers on All Sides

Downtown is bounded on all sides by barriers that make access difficult. The Arkansas River separates Downtown from North Little Rock, while railroad tracks and interstates limit access from the east, west, and south to only a handful of bridges.

Source: US Census Bureau

DTLR MOBILITY

Metrics & Benchmarking

The previously-outlined mobility challenges in Downtown Little Rock have made it a difficult place to navigate unless driving a personal vehicle. Downtown has lower walking, biking, and transit scores than all of its peer downtowns. Enhancements to the local trail network, transit system, and new bike lanes will all assist in making the area more walkable, bikeable, and navigable by transit.

How does Little Rock Compare?

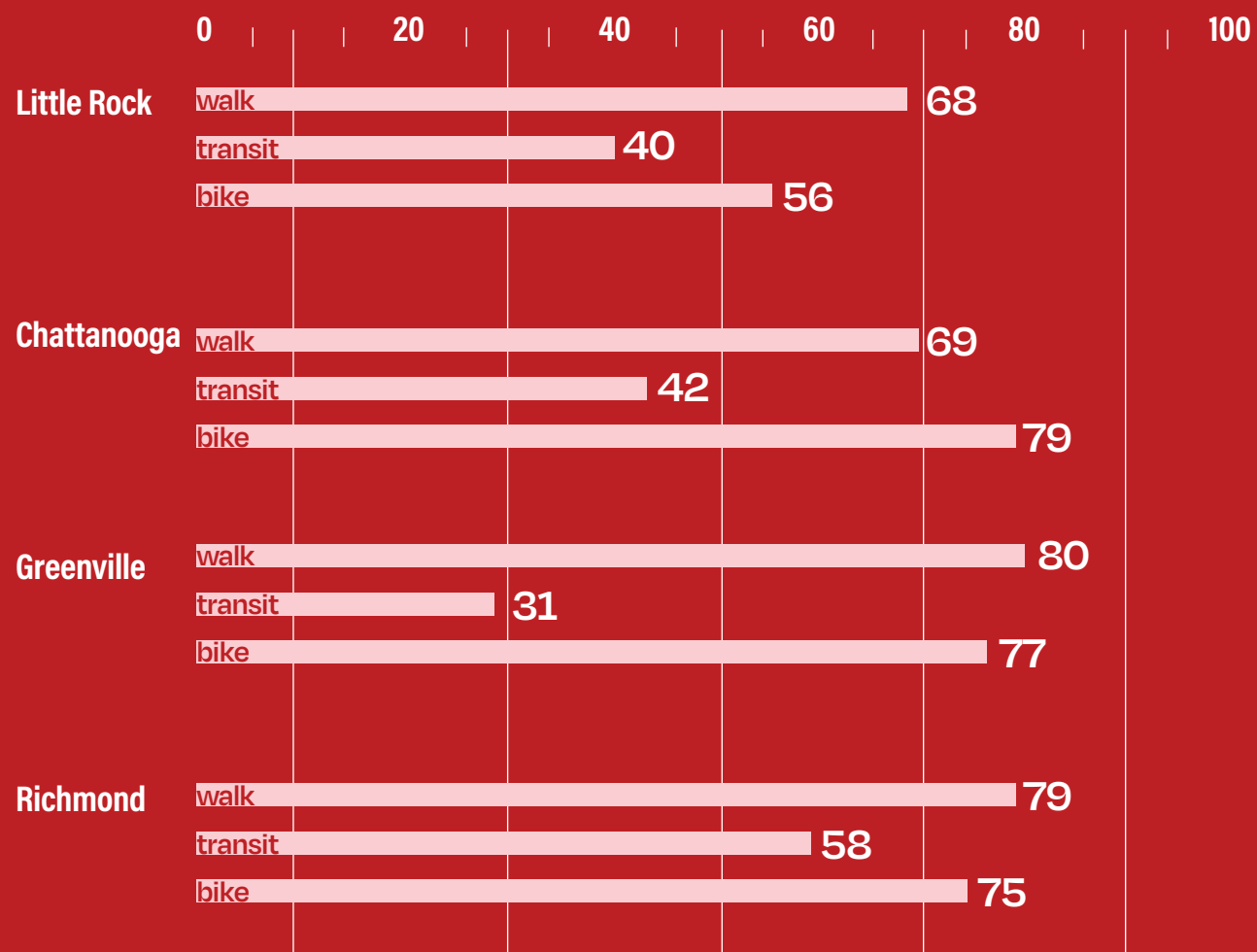

Source: Walk Score

WHAT WE HEARD

Downtown Little Rock was historically a walkable and transit-friendly neighborhood, with streetcars meandering its many streets. Over time, as the streetcars were removed and as streets were widened to accommodate vehicular traffic, streets became less accommodating to pedestrians and bikes.

The people of Downtown Little Rock desire improved multimodal options throughout and into Downtown, from surrounding neighborhoods and from across the River. The short, interconnected blocks are conducive to walkability. Improving sidewalks, street activity, and lighting is critical for ensuring a safe, comfortable environment for pedestrians.

People also desire better bike infrastructure Downtown to move between districts and to existing trails. Enhancing on-street and trail facilities in the area will create safe and inviting spaces for multimodal recreation and mobility. Lastly, people desire improved transit connectivity. This includes enhancements to the streetcar and bus systems.

Survey 1 Feedback on Transit and Mobility





WHAT WE HEARD



1 Infrastructure improvements are needed on downtown streets. Wider sidewalks and new bike lanes should be prioritized on key corridors to create a human-scaled, pedestrian friendly district.

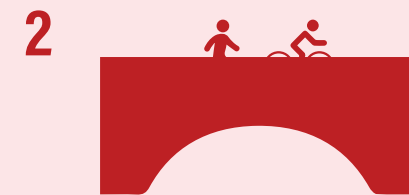

2 Improvements are needed at key gateways and along existing bridges to improve mobility into Downtown. This should include better sidewalks and bike lanes on numerous bridges.

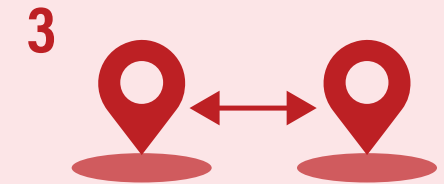

3 Improve neighborhood connections into the heart of the city that were severed by freeway construction. Existing bridges should be enhanced with wider sidewalks and bike lanes.



4 The transit system needs to be enhanced to better connect people from where they are (including where they live), to where they work or want to go (including key institutions and destinations).

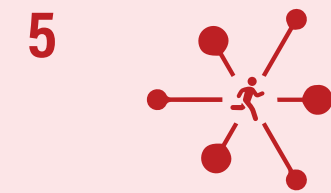

5 The proposed network of regional greenways and trails has the potential to make Downtown an epicenter for multi-mobility and outdoor recreation. Prioritizing new trail construction is essential to achieving this vision.

DTLR ECONOMY

Housing & Workforce

- Residential Buildings
- Public Administration
- Finance, Insurance, & Tech
- Health
- Education

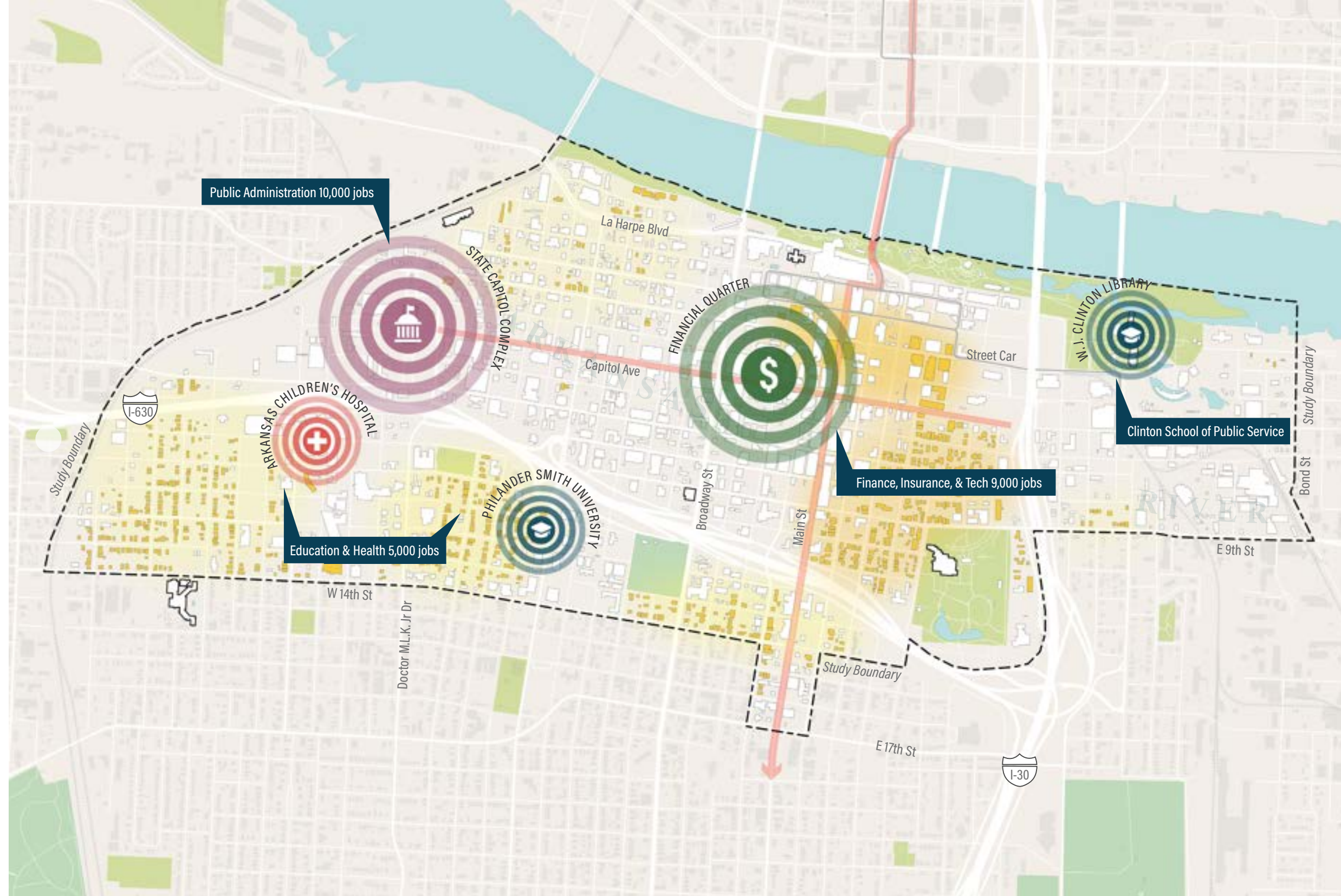

Downtown Little Rock is the heart of Central Arkansas' economy and is the largest concentrated job center in the State of Arkansas. Downtown has roughly 42,900 jobs, which is 13% of the total metropolitan area jobs, and 17% of Pulaski County's jobs. Even with its large size, employment downtown has only grown by 3% since 2003, compared with 14% for the metro area.

As the center of government for the State of Arkansas, Pulaski County, the City of Little Rock, Downtown has a very strong public administration sector, which has seen the largest job growth in

the last 15 years. Additionally, Downtown is home to Arkansas Children's Hospital, which has nearly 5,000 employees at its large Downtown campus. Other largest sectors include education, finance, and professional services.

Although Downtown is the largest job center, it lags substantially behind in residential population, with roughly 4,400 residents, or 0.6% of the metro area's total population. This jobs-housing mismatch has resulted in commuting patterns that are heavily skewed towards inward commuting,

with 99% of downtown workers commuting into downtown daily (SB Friedman Development Advisors, LLC).



DTLR ECONOMY

Existing Conditions

Market Inventory

Although Downtown only comprises 0.3% of the total land area of Pulaski County, it comprises a disproportionate amount of the County and region's development. There is 11.4 Million Square Feet of leasable office space, which is 34% of the County's total leasable office space. Additionally, there are 2,177 hotel rooms, which is 19% of the County total. Although Downtown is less of a retail center than it used to be, it still has over 2 Million square feet of leasable retail space, 6% of the County total. Lastly, there are 1,913 multi-family rental housing units Downtown, which is 4% of the total in Pulaski County.

Lack of Incentive Tools

The lack of substantial new development can be attributed, in part, to a low number of effective tax abatement and tax incentive tools that are found in many other cities. These public-private partnership tools, such as tax increment financing (TIF), help make projects more feasible by filling finance gaps in projects. Although Downtown Little Rock does have several existing tools, such as Historic Tax Credits, New Market tax Credits, and Opportunity Zones, these are limited in their geography, excluding the core of Downtown. Additionally, Historic Tax Credits are financially limited by current state law.

Three key financial tools that the City does not currently utilize Downtown but should explore are tax increment financing, public land disposition, and a development corporation that would acquire property and help provide gap financing. All of these tools will require new policies and implementation by the City. Although TIF is permitted in Arkansas, it has been sparingly used due to the lower amount of millage increment available for development. Even still, it is a strong tool that can help to fill financial gaps on redevelopment projects by covering site preparation and infrastructure costs. Public land disposition can help reduce barriers of entry by providing available land at a below-market rate, while development corporations are 501c3 nonprofits that promote site selection, workforce development, and implementation of economic tools.

Effects of COVID

Like most Downtowns, COVID saw a substantial decrease in the amount of activity and workers going to the area for a period of time. 2023 saw a gradual rebound from pre-COVID (2019) numbers, but the number of monthly employee visits remains around 654,000, down from 824,000, 80% of where it had been. Additionally, the total number of visits Downtown by visitors has decreased by 15,000 daily visits on weekdays (82% of pre-COVID levels), but weekends visits are at 92% of pre-COVID levels. While these numbers have presented challenges for retail and street activity in all Downtowns, these numbers should continue to gradually increase in the future, although it is unlikely that they will return to 2019 levels without new development.

New Construction vs. Historic Retrofits and Renovations

In comparison with the broader Pulaski County region, Downtown Little Rock has lagged behind in the delivery of new construction. Since 2010, Downtown has only delivered 12% of the total new office development (253,800 sf of new development), 24% of the new hotel delivery (450,000 sf of new development), 3% of the new multi-family development (313,000 sf of new development), and 2% of the new retail construction (49,500 sf of new development).

Much of the new space that has been delivered Downtown since 2010 has been renovations and retrofits of older, historic structures. Renovation of existing buildings has comprised roughly 62% of new office delivery, 43% of new residential development, and 20% of new hotel rooms. This has largely been enabled by substantial existing building stock and the availability of various historic tax credits. That said, due to this large amount of renovation, the number of large remaining vacant historic buildings is minimal (SB Friedman Development Advisors, LLC).



Source: Arkansas Tourism

Bernice Garden Farmers Market in SOMA

The Opportunity

Increase Housing Delivery

Due to the low number of available housing units and housing options, combined with the large number of jobs there is substantial demand for new housing. Vacancy rates are less than 5% across the district, an indicator of high demand. New housing developments should provide a spectrum of housing options, including not just multifamily, but also townhomes, condos, duplexes, and quadplexes. It is worth noting that current rents do not currently enable larger-format multifamily construction typologies to pencil and assistance from new incentive tools will be critical to ensuring future delivery.

Grow Private Sector Jobs

Even with the increase in public administration jobs Downtown since 2010, other sectors are stagnant or decreasing. This is in contrast to other downtowns which have largely been leading regional job growth. In recent years, banking and other headquarters have left downtown or decreased their presence. It will be critical to create the kind of environment and entrepreneurial ecosystem that will drive corporations and other employers to want to invest in downtown. This includes, safety, security, walkability, high quality of life amenities such as open spaces and recreation, and other daily-life amenities that support employment, such as retail, grocery stores, and daycares.

Nurture Thriving Retail Districts

There are three existing retail nodes in Downtown: the River Market, the northern end of Main Street, and the SOMA district, with a fourth beginning to emerge in East Village. Although these have found growing success in recent years, they are limited by low residential density and stagnant employment growth. New retail districts will be unsuccessful without the delivery of new housing. The expansion of the Main Street districts to connect with each other will help to create a singular, vibrant retail spine in the core of Downtown. That said, additional nodes should be explored (and subsidized, if possible) to encourage infill residential and office development in those areas.

Prioritize Incentive Tools

In order to deliver on the previously stated opportunities, it will be imperative for the City to take leadership in the creation and implementation of new incentive tools to help deliver the kind of new development desired. This can include, but is not limited to, the creation of one or more tax-increment financing (TIF) districts, the creation of a development corporation, and the disposition of city-owned land. Additionally, the City and Downtown Partnership should work with the State of Arkansas to explore changes in various state laws that present barriers to economic incentive tool implementation.

DTLR ECONOMY

Metrics & Benchmarking

To better understand market and economic conditions, Downtown Little Rock was compared to similar-sized cities, including Chattanooga, TN, Greenville, SC, and Richmond, VA. This analysis revealed that outside of hotel room delivery, Downtown Little Rock lags behind in all market sectors, including retail, office, and multifamily units. As important, Little Rock's Downtown is also up to four times less dense than comparable downtowns, leading to a sense of lifelessness.

How does Little Rock Compare?

			POST 2010 DEVELOPMENT			
	Downtown Population	Downtown Density People/sq. mi.	Retail Downtown (SF)	Leasable Office Space (SF)	Multifamily Rental Units	Hotel Rooms
LITTLE ROCK	4,395	1,758	49,500	253,800	245	463
			52,700	421,200	183	820
			102,200	675,000	428	1283
CHATTANOOGA	3,745	4,161	114,900	165,900	988	535
			85,900	474,500	69	343
			200,800	640,400	1,057	878
GREENVILLE	7,141	4,760	309,500	947,000	2,380	1,558
			116,200	804,900	197	200
			425,700	1,751,900	2,577	1,758
RICHMOND	27,565	7,875	124,900	2,108,900	8,178	627
			173,800	1,935,100	1,423	1,425
			298,700	4,044,000	9,601	2,052

New Development
Renovation
Total

Source: SB Friedman Development Advisors, LLC

WHAT WE HEARD

Although Downtown Little Rock is the heart of Central Arkansas, and its largest job center, it is struggling in comparison to the region as a whole.

Stakeholders desire for Downtown to be the beating heart of urban life for the region. That includes the desire for the area to provide more daily needs retail, such as a grocery store to improve residential life. Critical to this is providing more housing, of all types, to provide options for would-be residents and increase retail success and district vibrancy.

There is also a desire for the area to be more of a draw for visitors, including providing safety and quality of life enhancements that attract and retain employers and promote tourism. Part of this is simply improving the narrative of Downtown, communicating to the city, the region, the state, and the nation that Downtown Little Rock is a popular, vibrant, and safe place to hang out.

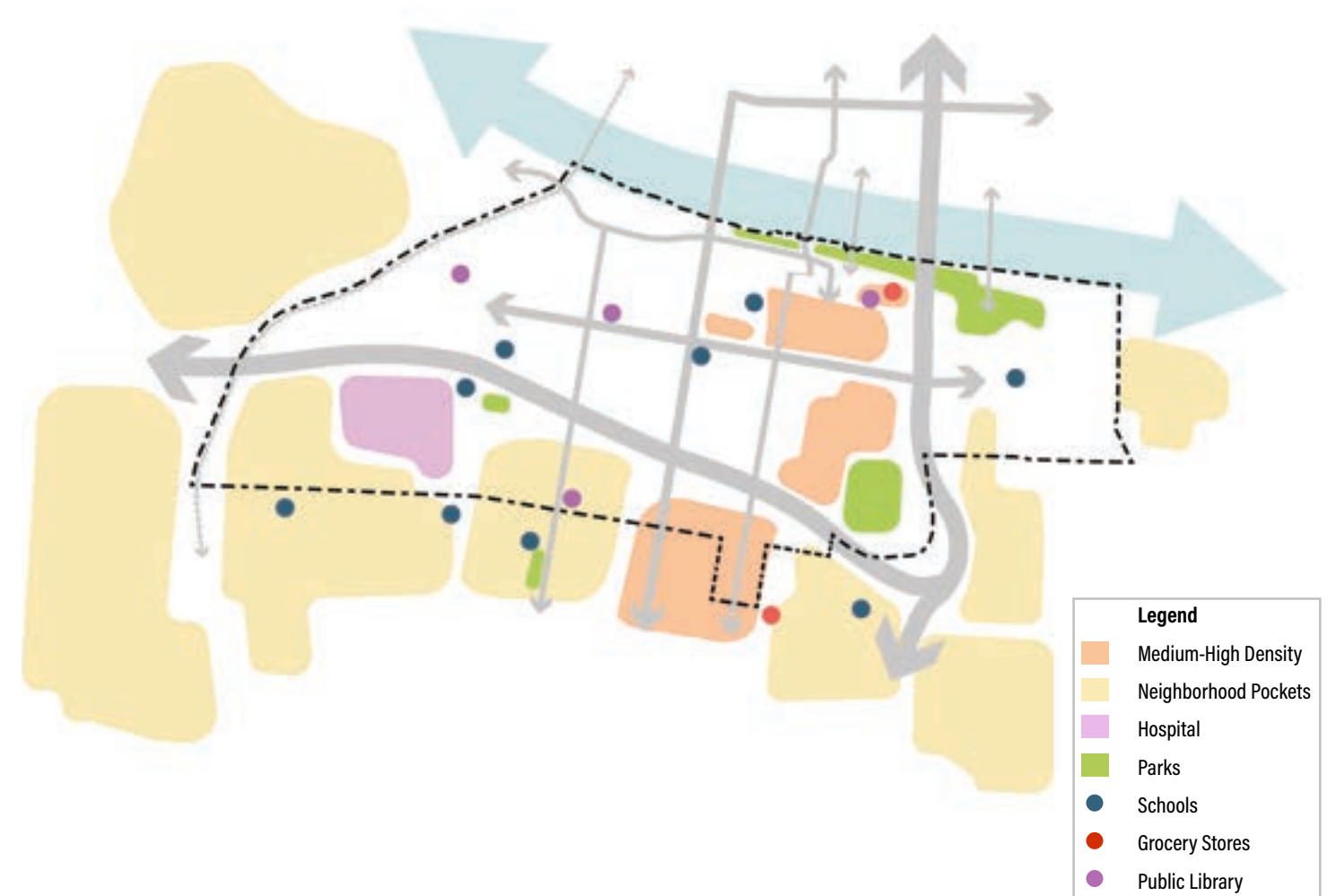

- Legend**
- Medium-High Density
 - Neighborhood Pockets
 - Hospital
 - Parks
 - Schools
 - Grocery Stores
 - Public Library



WHAT WE HEARD

1



Although Downtown is still Central Arkansas' largest job center, job growth is marginal and some employers are leaving.

2



There is a large mismatch between the number of jobs and the number of residents. That said, multi-family rental occupancy is at 96%, meaning there is very strong demand for new housing.

3



Although COVID has had an impact, numbers have rebounded close to 2019 levels. It is unlikely that the number of visitors will fully return to 2019 levels without new development.

4



Enhancing and expanding the existing retail nodes, and establishing at least one additional retail node, will help to create a new district identity and drive further residential and office demand.

5











Little Rock should deploy a suite of incentive tools to help provide gap financing to potential projects. This will be critical in making delivery of new housing possible.

DTLR CULTURE

Amenities & Institutions

Legend

-  Local Historic District
-  National Historic District
-  Activity Centers
-  Open Space
-  Hotels
-  Institutions
-  Institutional Campus
-  Historic Sites

- ① 7th Street Murals
- ② Arkansas Heritage Office
- ③ Statehouse Convention Center
- ④ First Security Amphitheater
- ⑤ Witt Stephen's Jr. Central Arkansas Nature Center
- ⑥ W. E. Clark Presidential Park Wetlands
- ⑦ Clinton School of Public Service
- ⑧ Lyon College Schools of Veterinary Medicine & Dentistry
- ⑨ UALR W. H. Bowen School of Law
- ⑩ MacArthur Museum of Arkansas Military History
- ⑪ Little Rock Technology Park
- ⑫ US District Court House
- ⑬ Dunbar Community Center & Garden

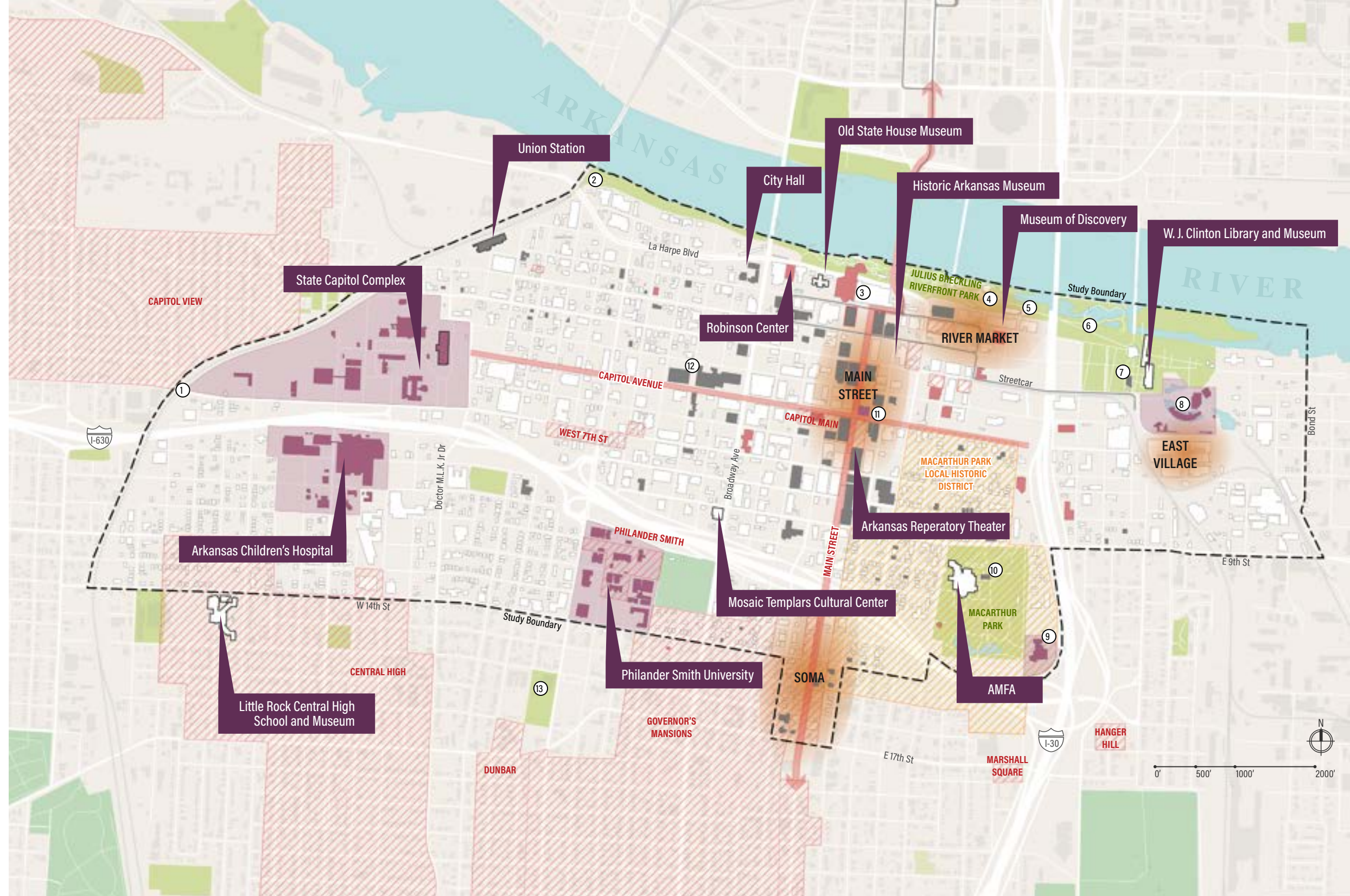

Downtown is home to some of Little Rock and Arkansas' most important historic destinations, including the Arkansas State Capitol, the Old State House, the Historic Arkansas Museum, and Little Rock Central High School. The core of the city also contains key institutions, including Arkansas Children's Hospital, Philander Smith College, the US Federal Courthouse, the Little Rock Tech Park, the Clinton School of Public Service, and the UALR Bowen School of Law. Additionally, Downtown contains several cultural and entertainment destinations,

including the William J. Clinton Library and Presidential Museum, the Arkansas Museum of Fine Arts, the Mosaic Templars Cultural Center, the Museum of Discovery, the Arkansas Reperatory Theater, Robinson Auditorium, and First Security Amphitheater. These are all tremendous assets for Downtown to celebrate and build upon in the future.

Although Downtown is blessed with the largest consolidated collection of cultural and historical assets

in the state, many are disconnected from each other. Enhancing connectivity between these assets through improved infrastructure and transit will improve the experience for those visiting downtown while also driving innovation and collaboration amongst these entities. It will also enhance Downtown as a destination and common ground for all of Little Rock's many diverse communities.



DTLR CULTURE

Existing Conditions

Celebrating History

Downtown Little Rock is one of the oldest permanent settlements in the State of Arkansas, and is of critical importance to the history of the State and the United States. It is home to important Indigenous history, including the Quapaw nation and the Trail of Tears, and Civil Rights History, including Little Rock Central High School. Celebrating the many histories of Downtown will reinforce it as the true heart of Arkansas. Critical to this is ensuring that historic assets are maintained and protected, ensuring their enjoyment for future generations.

Eds and Meds

Downtown has a wide range of higher-education and medical institutions that provide daily activity and are some of the district's largest employers. The University of Arkansas-Little Rock (UALR) has its Bowen School of Law adjacent to MacArthur Park, and they also have a small presence for the main institution in the River Market. The University of Arkansas' Clinton School of Public Service lies adjacent to the Clinton Library. Philander Smith University is a small HBCU just south of I-630 and anchors the Dunbar neighborhood. Other key institutions in Downtown are the Little Rock Technology Park along Main Street and Arkansas Baptist College, which lies just south of Downtown.

Downtown is also home to one of the largest concentrations of medical jobs in the State. Arkansas Children's Hospital, just south of the Arkansas State Capitol, is a 2 Million square foot facility that employs over 4,000 workers. Just west of Downtown is the University of Arkansas for Medical Sciences (UAMS), the Arkansas State Hospital, and the VA Hospital. Together, this medical district comprises the largest concentration of healthcare jobs in Arkansas.

Opportunities exist for these institutions to better partner and collaborate on research and programming that will drive innovation. Better connecting these institutions to each other while also providing synergistic land uses near them will reinforce and enhance them as key assets within Downtown.

Events and Programming

Downtown Little Rock has long been home to various big events and frequent programming that provide activity for those that live and work in the area while also attracting visitors to the area. Although large events such as Riverfest no longer exist, there are numerous newer events, such as the Main Street Food Truck Festival, and recurring smaller events such as farmers markets, concerts, and other entertainment. These events, largely managed by the Downtown Little Rock Partnership and the Little Rock Convention and Visitors Bureau, are great additions and well-received by all walks of life in Central Arkansas.

A Center of Culture

Downtown is a melting pot of broader Little Rock culture, serving as a common ground for Little Rock's diverse communities, including the Black, Hispanic, and LGBT+ community. Its residents and workers are highly socioeconomically and culturally diverse, and that is reflected in its cultural assets. Downtown is home to a thriving art scene, including the Arkansas Museum of Fine Arts, the Arkansas Repertory Theater, Ballet Arkansas, the Arkansas Symphony Orchestra, and other smaller venues. There are historic museums, including the Old State House, the Historic Arkansas Museum, Mosaic Templars Cultural Center, Little Rock Central High School, and the MacArthur Museum of Arkansas Military History. And there are educational museums such as the Clinton Presidential Center, the Museum of Discovery, the Central Arkansas Library System (CALs), and the Witt Stephens Jr. Central Arkansas Nature Center. All of these drive tourism and visitors to downtown.

89 registered historic structures Downtown

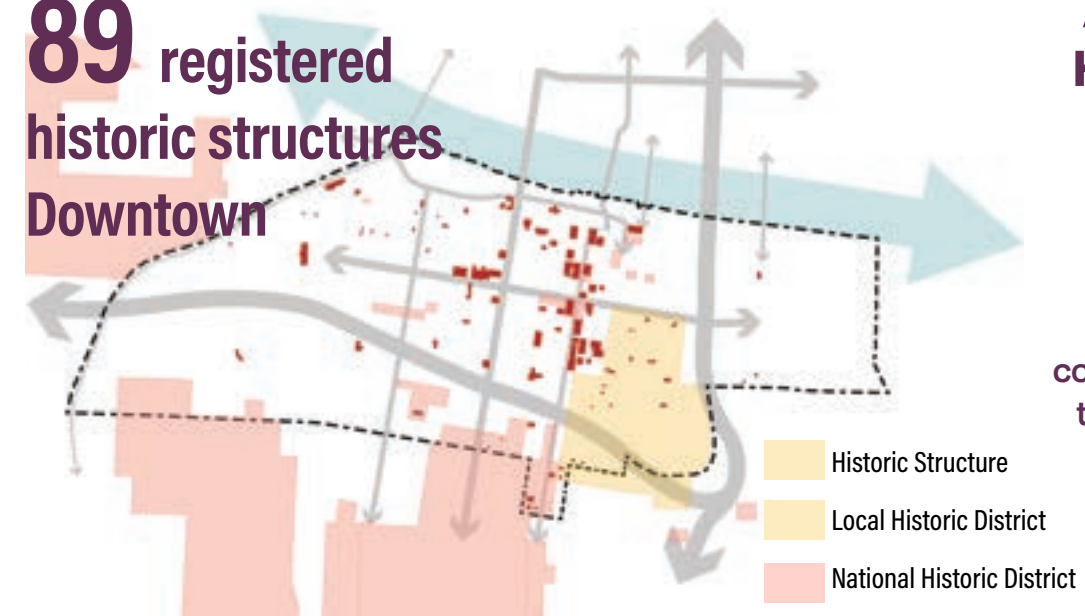

A Collection of Historic Sites & Districts

Downtown Little Rock has numerous historic neighborhoods and assets, with the largest concentration located near the Main Street corridor.

6 Institutional Campuses Downtown

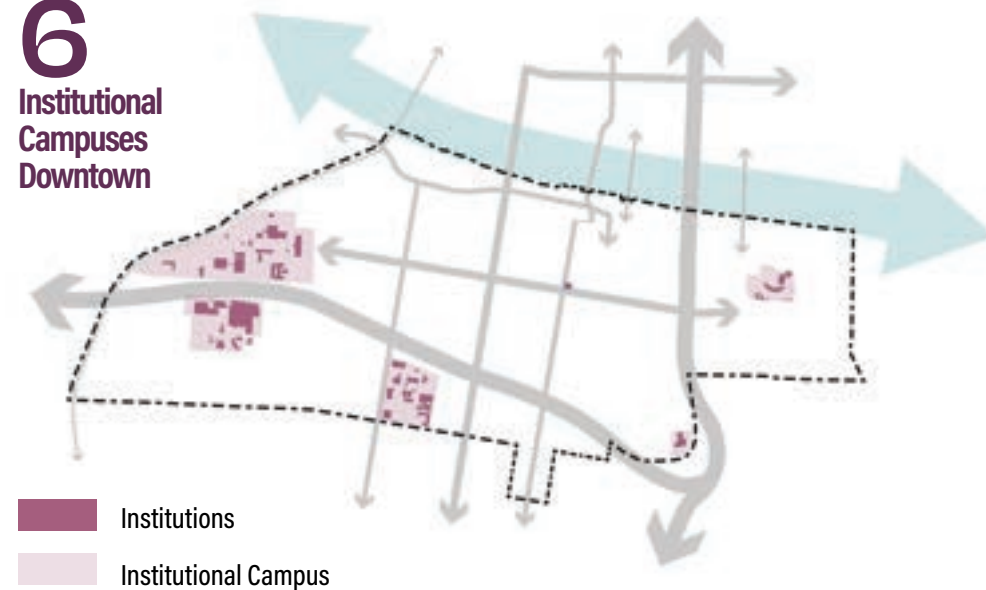

Disconnected Institutions

Most of Downtown's key institutions are located on the periphery, leaving them disconnected from hotels, popular neighborhoods, and places of interest like the Arkansas River.

14 Hotels Downtown

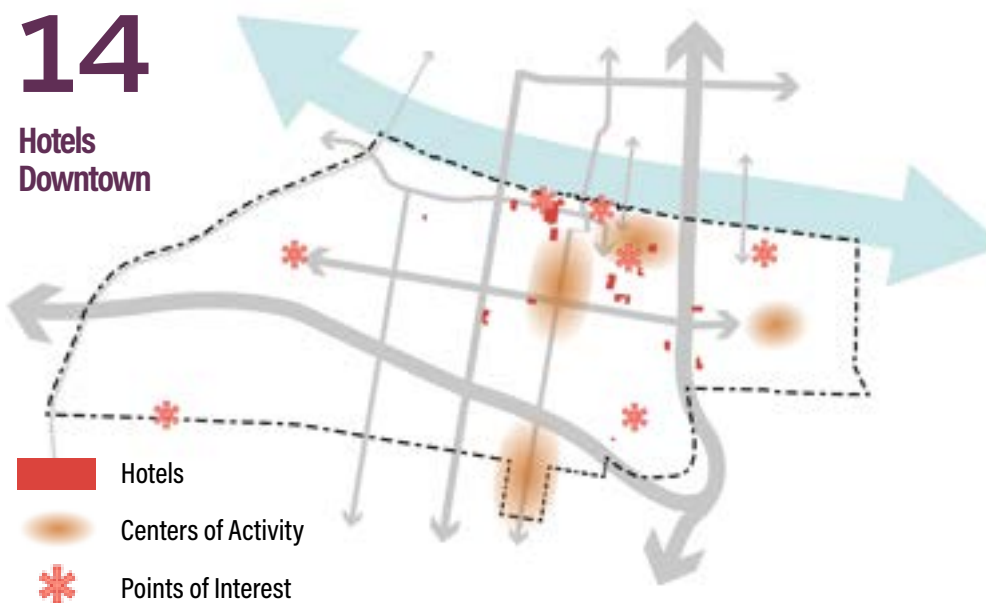

Hotels Disconnected from Tourism Destinations

Downtown's main points of interest and popular neighborhoods are scattered throughout the area, however most hotels are concentrated in the River Market, with poor connectivity to other places people want to visit.

DTLR CULTURE

Metrics & Benchmarking

When it comes to visitors and their expenditures, Little Rock displays comparable or higher number than cities of similar size. Little Rock has a strong opportunity to further highlight and connect its existing cultural amenities and to offer new opportunities within the urban core for visitors to experience the city's rich culture.

How does Little Rock Compare?

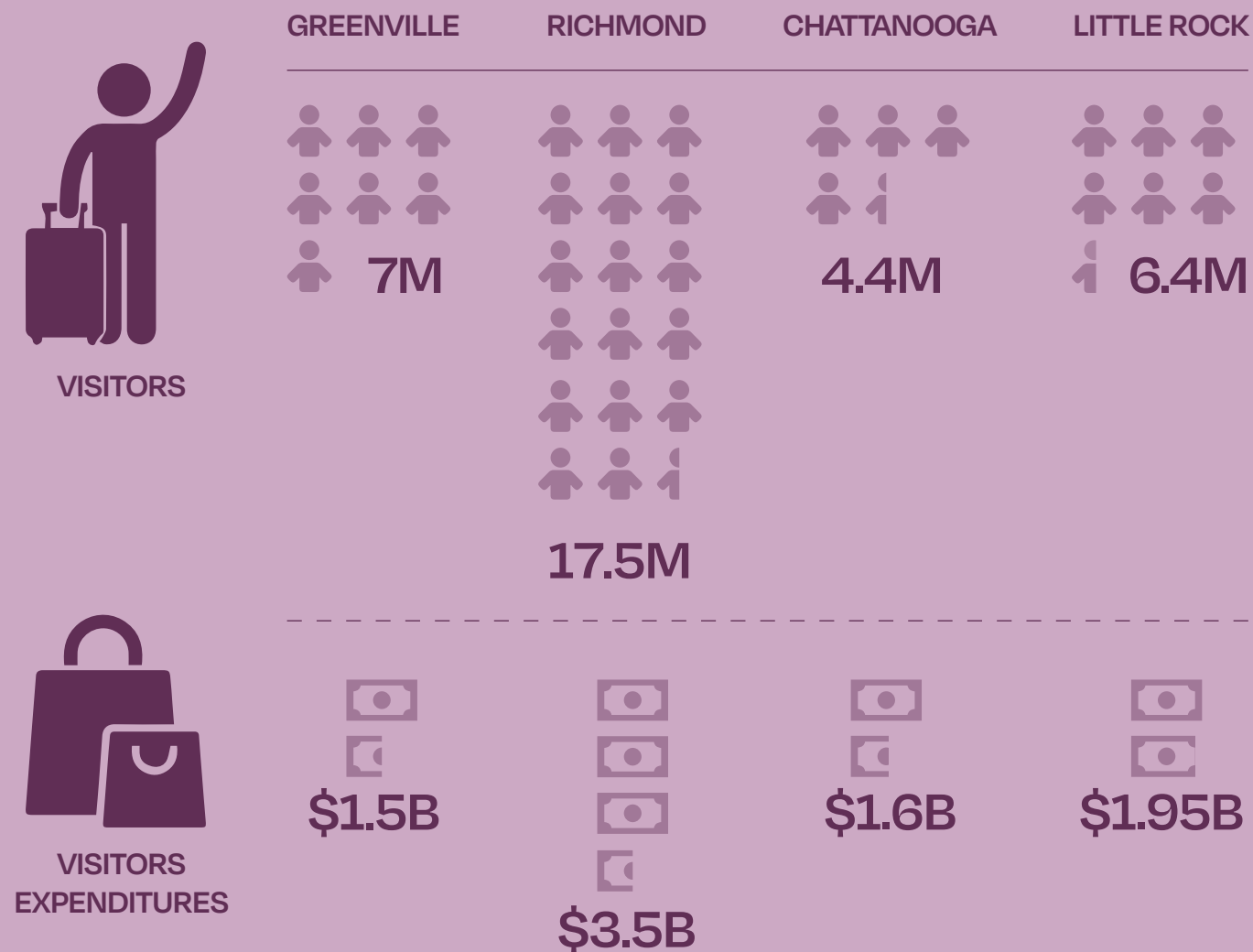

Source: SB Friedman Development Advisors, LLC

WHAT WE HEARD

As the great single concentration of history, culture, and institutions for the entire State of Arkansas, Downtown Little Rock is well positioned to be an epicenter for cultural life. That said, it currently faces perception issues and mobility barriers that limits its success. Downtown stakeholders desire for the district to be easier to navigate between key assets, including museums, tourist destinations, and districts. These assets are currently disparately located, so making enhancements between districts will be critical. Part of this includes better celebrating the historical buildings and assets, including protecting existing buildings from future demolition.

Stakeholders also believe that the great history that exists Downtown, whether it be Indigenous, Civil War, Civil Rights, or American history, could be improved and utilized to drive tourism and education. Lastly, Downtown also struggles to be a true center for higher education, although it includes many higher education and medical institutions. Stakeholders desire more accompanying amenities, including housing and open space, to make the space more appealing to students.

Survey 1 Feedback on Culture





WHAT WE HEARD

1



Downtown is an epicenter of Arkansas and National history and culture that should be leveraged to better attract tourism and visitors.

2

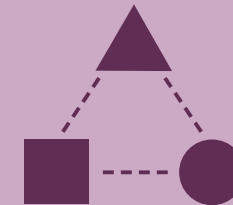

Existing cultural, higher-education, medical, and employment assets are largely disconnected from each other. Multimodal and transit enhancements are needed to make moving between each of these easier.

3



A great deal of Downtown's historic fabric has been demolished. Preservation of existing historic structures should be prioritized, although it is important that red tape is removed to make infill development easier.

4

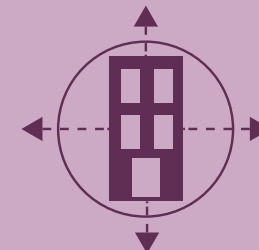

Existing institutions should become the nodes for their area of Downtown, with synergistic land uses such as housing and retail surrounding them.

5

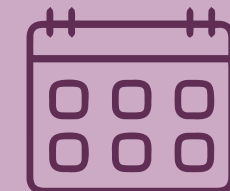

Events and programming in Downtown are popular and should be better promoted and expanded to create more opportunities for potential visitors while also improving the vibrancy of the district.

DTLR OTHER THEMES

Existing Conditions

Perceptions of Downtown

Throughout the planning process, a clear narrative about Downtown Little Rock emerged from community leaders and the public at-large: Downtown is struggling, it's unsafe or unsavory, and it's not a desirable place to spend time. What also emerged through the engagement process was that most people know that this narrative is not necessarily rooted in facts but instead in the way the City, Region, and State perceive Downtown Little Rock. This negative narrative and perception needs to change, and it will be incumbent upon the City, the Downtown Partnership, the Convention and Visitors Bureau, and others to make a concerted effort to reframe the conversation and tell the great and exciting things occurring Downtown. In order to do that three key issues should be addressed.



Downtown Ambassador Program

Concerns about Safety

When compared to other areas of Little Rock, crime in Downtown Little Rock is lower on a per-capita basis than many areas of the City, including Midtown and West Little Rock. And while an area with upwards of fifty-thousand daily visitors is guaranteed to have some level of crime, violent crime in Downtown is particularly lower when compared to other areas. Unfortunately, the narrative by many is that the area is unsafe. This is often due to the lack of activity. Individuals often cited fears of walking on poorly-lit streets at night as the sole person present. This is compounded by issues of vagrancy and panhandling exacerbating safety concerns. And while little crime is occurring, these issues are valid and will require an enhanced response to ensure all visitors feel comfortable and safe. The newly-created Downtown Ambassadors Program is one step in improving safety by deescalating potential situations and by providing free walks to your car upon request.



Plaza at Capitol and Main



A lifeless corridor in Downtown Little Rock

Concerns about Homelessness

Downtown Little Rock, like many downtowns, is the epicenter for many services for the region's unhoused population. Unfortunately, like in so many areas of the country, the unhoused population is increasing in Little Rock due to mental health, substance abuse, and affordable housing issues. Most estimates put the unhoused population at over 1,000 individuals and many of those folks spend time Downtown seeking services. Providing these services in a safe and humane way is essential, but it is also important to ensure that these services do not create undo impacts on their neighborhoods. Luckily, the City is already undertaking important steps to help provide care and housing for these folks, including a new "tiny home" village south of Downtown. Additional investment and housing will be needed and should be explored in and around Downtown



Microvillage for Little Rock unsheltered community members

Creating a Unified Message

Due to the issues previously outlined, Downtown lacks a single positive message or narrative that supporters and stakeholders can profess in spreading the good news about the district. A clear, concise, and unified message is key to enticing future development and investment by residents and businesses, while also attracting new visitors and tourism. The vision outlined in the Executive Summary, supported by the six key values outlined in the plan, are a starting point for this unified message. When all stakeholders reinforce the same positive message through media blasts, tourism campaigns, and simple word-of-mouth, the overall perception and narrative of Downtown will change: Downtown Little Rock is THE place to be!



4

Vision



Developing a Guiding Vision

Once a detailed analysis of conditions related to the city's urban fabric, parks and open space, mobility, economy, and culture and institutions was completed, ideas from the community, emerging opportunities, and identified constraints helped shape the development of four big ideas.

The strategies outlined in each Big Idea are captured in greater detail in the Implementation Chapter, although not every Big Idea contains every strategy due to its granularity. When the four Big Ideas and four Focus Areas are layered together, they develop the Guiding Framework for Downtown Little Rock. This Guiding Framework is designed to be bold, yet achievable, flexible, yet structured, so that the Master Plan can serve as a planning and development tool for years to come.

Vision Statement

Downtown Little Rock is the heart of urban life available for all of Arkansas – a safe and vibrant hub for history, culture, activity, and recreation along the banks of the Arkansas River.

Downtown is a constant pulse of activity - a highly-desired place to raise a family, work, and socialize because it is a diverse and inclusive collection of neighborhoods and people.

BIG IDEAS

Envisioning a Plan

Each of these four Big Ideas outline visionary and bold strategies for achieving the desired shared vision for Downtown. These four big ideas form a central guiding framework that guide all recommendations and actions in the Implementation Chapter.



THE BIG IDEAS

1 A Tapestry of Neighborhoods

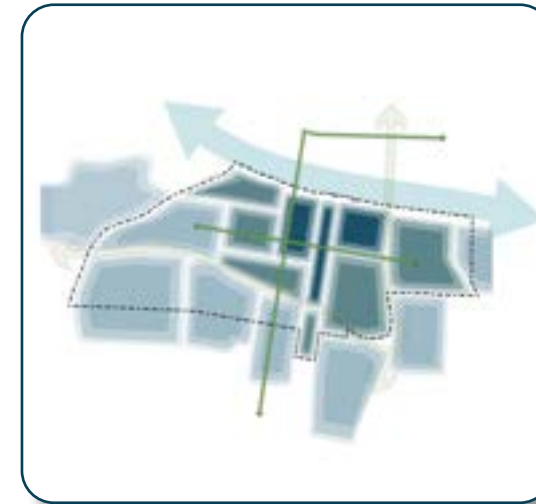

2 Rambles to the River

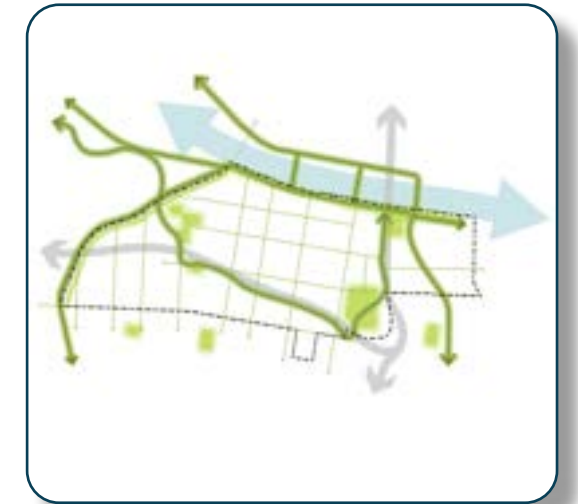

3 Loop, Stitch, and Reconnect

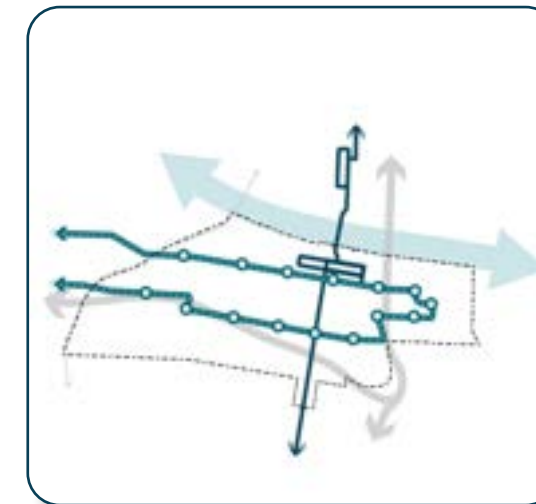

4 Culture as a Catalyst

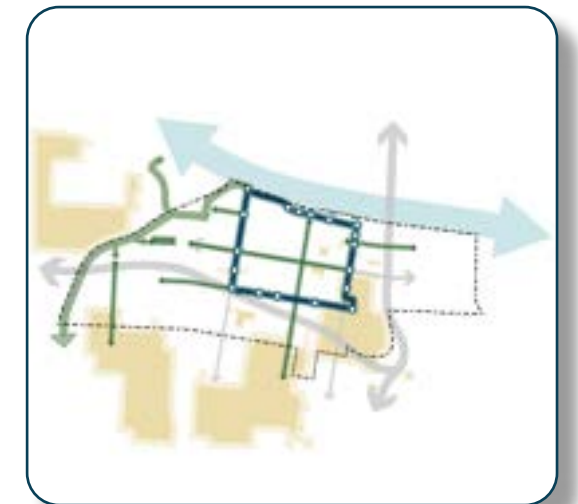

» **A Tapestry of Neighborhoods:** Build off existing character to establish an identifiable neighborhood pattern and support residential growth.

» **Rambles to River:** Create an interconnected network of trails, green streets, and park nodes.

» **Loop Stitch and Reconnect:** Reposition transit and transportation networks to connect people from where they are to where they need and want to go.

» **Culture as a Catalyst:** Utilize cultural and historic assets as a catalyst for growth, community identity, and placemaking.

WHAT WE HEARD

The second community engagement event was held at the Still Ballroom in the Robinson Center. Over one-hundred-and-fifty people attended and contributed feedback. Attendees were each given a cup of ten "little rocks" to place in jars on the prioritization board. The board contained nine strategies for each of the four Big Ideas. Community members were asked to vote by placing their "little rocks" in jars associated with the strategies most important to them.

The Game Board

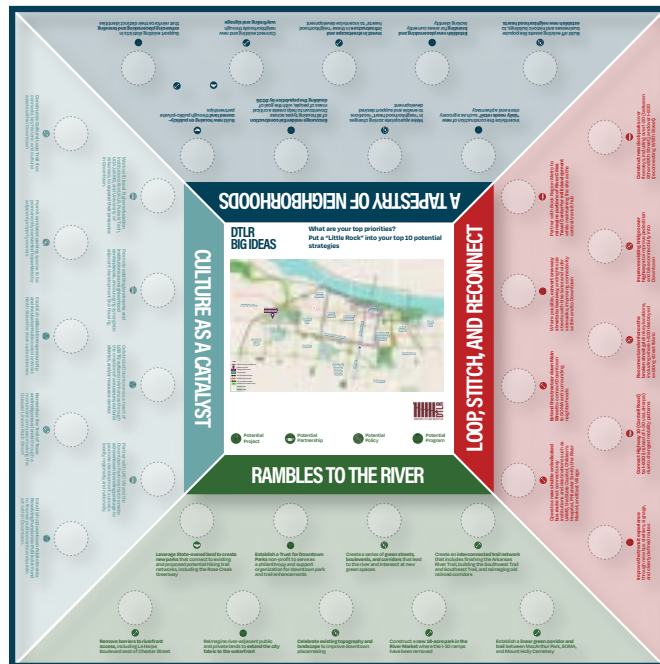

The Rules

- 10 "Little Rocks" per person.
- 9 different strategies made of Projects, Policies, Partnerships, and Programs per Big Idea.
- Place only one marble per item for your top priorities!

Ranking Priorities

In addition to voting at the meeting, community members had the opportunity to submit their priorities online. A total of 819 people participated in the survey. The following priorities of projects, programs, policies, and partnerships for each of the four themes emerged from the in-person and online feedback.



A Tapestry of Neighborhoods

- 1 Incentivize new "daily needs retail"
- 2 Enhance branding in existing districts
- 3 Invest in streetscapes and infrastructure
- 4 Establish new neighborhood hearts
- 5 Encourage residential construction

Rambles to the River

- 1 Create a series of green streets
- 2 Remove barriers to riverfront access
- 3 Leverage State-owned land to create parks
- 4 Create an interconnected trail network
- 5 Establish a Trust for Downtown Parks

Loop, Stitch, and Reconnect

- 1 Operate a bus route connecting institutions
- 2 Extend the streetcar down Main Street
- 3 Reconnect and enhance the street grid
- 4 Improve existing bridges over highways
- 5 Connect Highway 10 to I-630

Culture as a Catalyst

- 1 Establish a Public Events Revolving Fund
- 2 Construct a Cultural Loop Trail
- 3 Create a Downtown branding package
- 4 Expand higher ed presence downtown
- 5 Establish a Black Entrepreneurship Hub

A TAPESTRY OF NEIGHBORHOODS

Downtown Little Rock is not just one district, nor is it just one history, set of people, or singular idea. It is a kaleidoscope of cultures, neighborhoods, and people which make it a special and unique place. As a common ground for Little Rock's White, Black, Hispanic, Asian, Immigrant, and LGBT+ communities, it is important to celebrate and uplift this tapestry of neighborhoods that, when stitched together, create what is known collectively as Downtown. Telling the history of each of these areas and celebrating each district's unique attributes is essential in deconstructing the monolith of Downtown. This should be done through placemaking, wayfinding, branding, and signage which reinforce each area's unique characteristics."

Creating a quilt-work of different districts is essential in developing Downtown as a livable community. This will require building a variety of housing choices, at a variety of price points, with the goal of doubling Downtown's population in the coming decade. This will, in turn, also require investments in quality of life, such as parks and open spaces, daily-needs retail, and improved perceptions of safety and security to ensure that Downtown is one of the best neighborhoods to live in Little Rock.

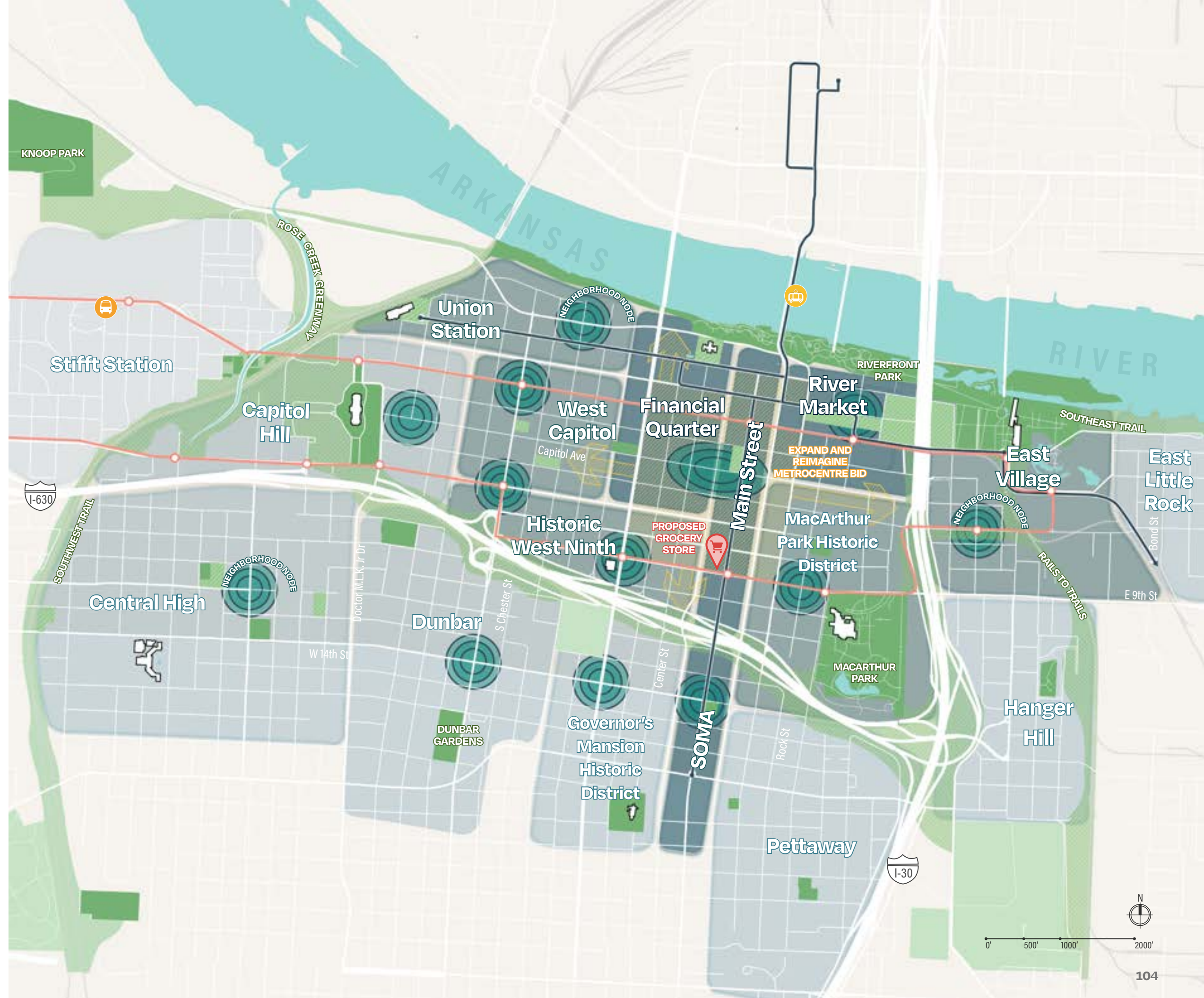

Legend

- Neighborhoods
- Proposed Neighborhood Hearts
- Existing and Proposed Trolley Route
- Proposed Bus Rapid Transit Route
- Existing and Proposed Trail Network
- Enhanced Pedestrian Crossing
- Existing Open Space
- Proposed Open Space
- Existing/ Expanded Metrocentre BID

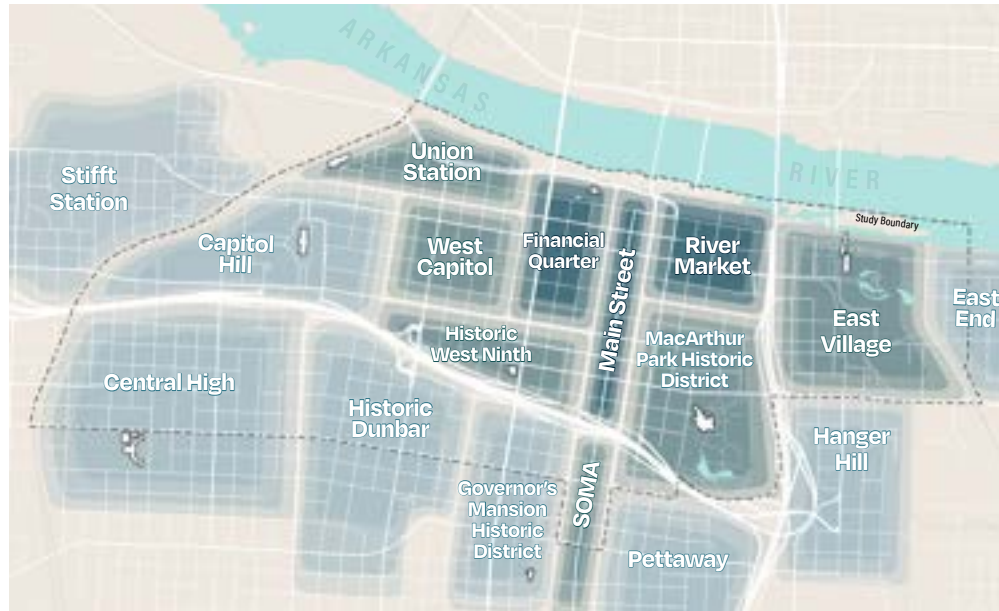

Create Neighborhood Identity

Downtown Little Rock has many areas with unique character like SOMA, River Market, and Main Street. Other areas can benefit from establishing new identities and enhancing existing character.

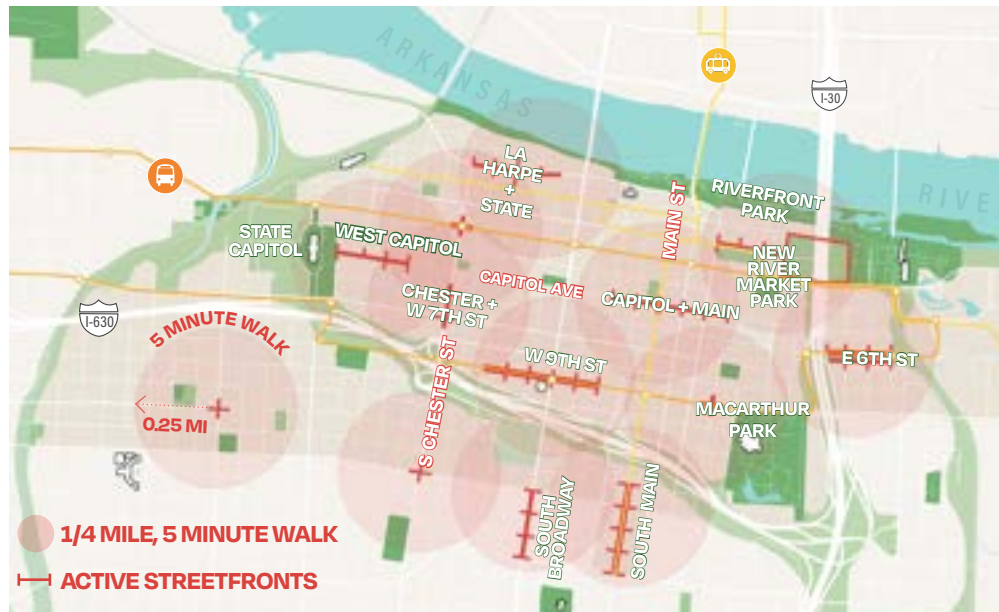

Quarter-Mile Main Streets

Every great neighborhood has a heart where people gather to shop, dine, and socialize. New infrastructure improvements and appropriate zoning can help enhance these areas and catalyze new investment.

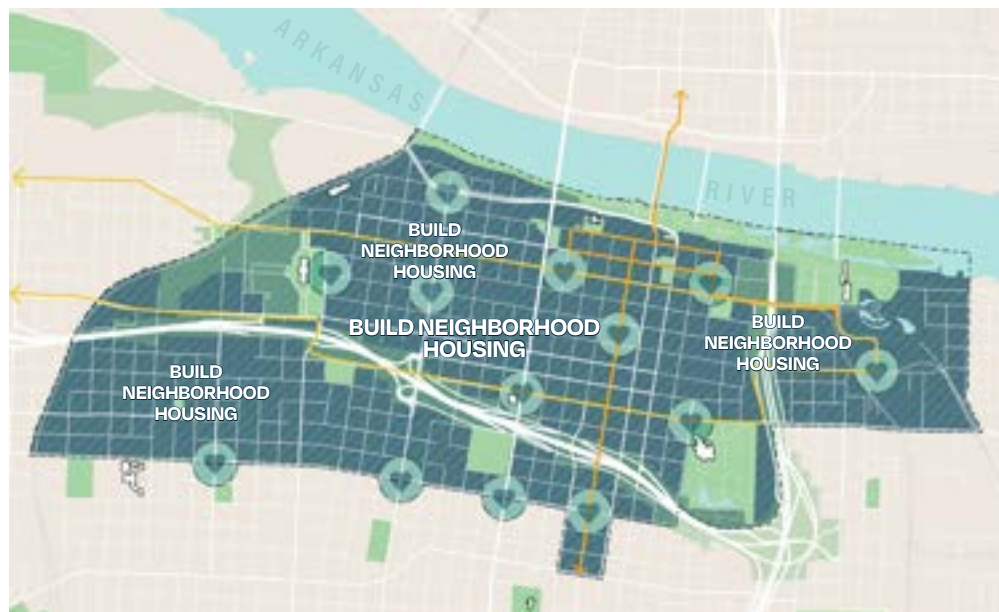

Building More Housing Options

Surrounding each neighborhood, there is opportunity to create more infill housing. Increasing downtown density will help enrich neighborhood hearts by making them places that are active and vibrant. Downtown should double its population by 2035.

CASE STUDIES

Des Moines, IA

Des Moines unique and distinct neighborhoods give the city a rich cultural fabric. The 2018 Neighborhood Revitalization Planning Program identified areas where housing had fallen into poor condition and then created Special Investment Districts to improve housing quality and diversity as well as increase home ownership. The 2022 Downtown Plan recommends creating a Community Core Neighborhood Alliance to help reactivate neighborhood nodes as centers for urban life.



Source: City of Des Moines
Downtown Des Moines Neighborhoods

15-Minute Cities

A growing movement among many cities is to strive to provide amenities near to where people live, ideally within a 15-minute walk or biking distance. By focusing growth in key nodes around Downtown, the other areas should be able to easily access any of their daily needs nearby, reducing the need for car use as frequently.



Source: Lee, Hoyoung
Bishop Arts District- Dallas, TX

Housing Types

Historically, cities were built with a range of housing types, from dense apartments to single-family homes. Zoning made many of these housing options illegal or difficult to build, resulting in more unaffordable housing choices. Infilling areas of Downtown with duplexes, quadplexes, townhomes, and small apartments would provide affordable housing options and housing choices, and increase population, helping improve retail viability.



Source: MAA Greene Apartments
Downtown Greenville, SC

RAMBLES TO THE RIVER

Downtown Little Rock is defined by the incredible natural asset of the Arkansas River. Although there are nice open spaces and park moments along the River, the experience could be enhanced both in how the riverfront is designed and how people access the water.

Key to the Rambles to the River idea is creating clear green street corridors that serve as direct connections to the River from the core of Downtown and surrounding areas. This also includes substantial trail improvements and new trails connecting with the Arkansas River Trail. This network of green streets, trails, and open spaces will ensure high quality of life for those Downtown and will help to celebrate Little Rock as the Capital of The Natural State. Creating these investments and enhancements in open space, trails, and outdoor recreation will dramatically improve quality of life for existing and new residents and will drive new investment and demand for living, working, or visiting Downtown.

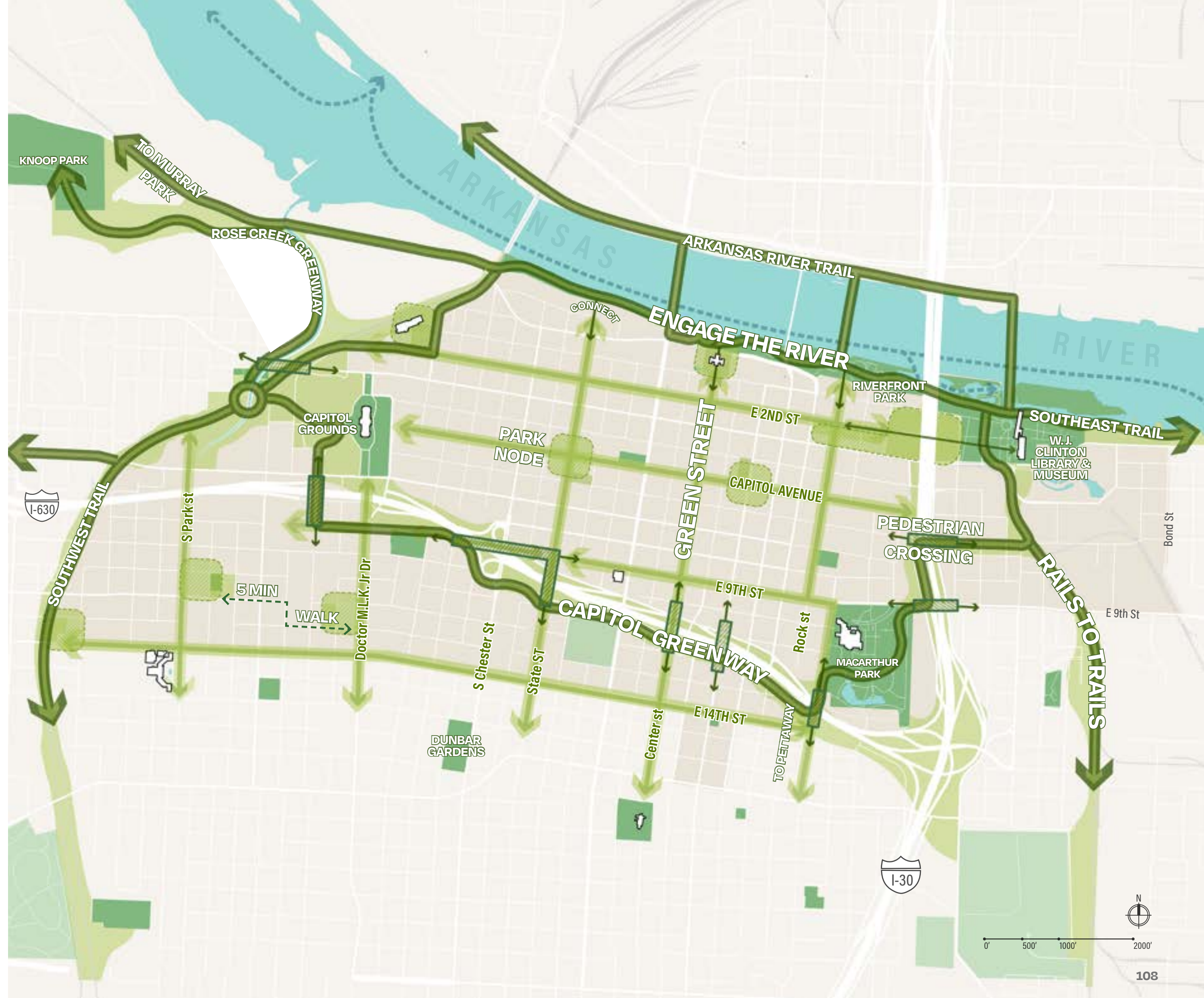

Legend

- Existing/Proposed Regional Trail Network
- Priority Green Street
- Proposed Park Node
- Enhanced Pedestrian Crossing
- Existing Open Space
- Proposed Open Space Network
- Proposed Blue Trail (boat, kayak, etc.)



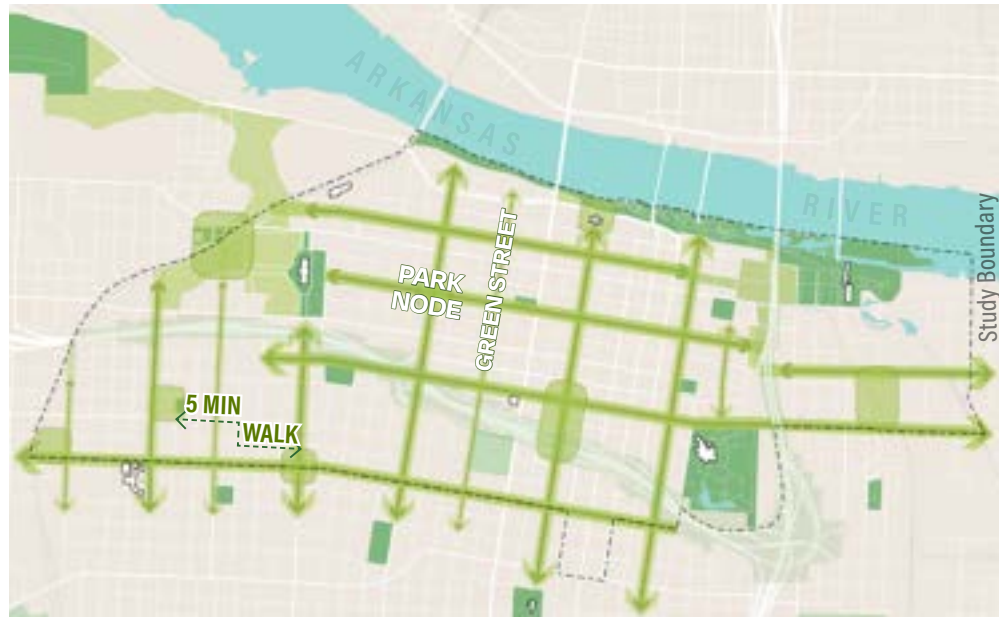

Remembering the 1913 Plan

The 1913 Little Rock Parks System Master Plan included a vision for connecting the city to the river, creating a series of greenways along stream corridors, and implementing a series of green streets connecting neighborhoods to parks.



Re-orienting to the River

The Arkansas River is Little Rock's greatest natural asset, yet much of downtown has turned its back to it. Reimagining development to face the river and the riverbanks as a community hub will allow the city to embrace all this feature has to offer.



Interconnected Trail Network

Trails are a key avenue for people to access green spaces in the city and the beautiful riverfront. The Southeast and Southwest Trails can be expanded and offer new connections to stitch the city together for cyclists and pedestrians.

CASE STUDIES

Moore Square

Raleigh, NC

This \$13M park was fully reconstructed in 2019 as a redesign of one of Raleigh's five original parks from its 1792 city plan. The new park is a downtown gathering space that is surrounded by a children's museum, retail spaces, restaurants and nearby high-rise apartments. The heavily programmed space offers events from outdoor movies to live music and pop-up markets.



Moore Square in Downtown Raleigh, NC

Falls Park

Greenville, SC

Falls Park, a \$13M project, revived downtown Greenville when it opened in 2004 and spurred over \$100M in private development in the surrounding area in only two years. The iconic pedestrian bridge over the falling water replaced a six-lane highway that blocked access to the riverfront.



Source: Rosales + Partners

Falls Park on the Reedy in Greenville, SC

The Beltline

Atlanta, GA

A former railway loop around the city, the corridor now serves as a 22-mile shared-use path that connects 45 neighborhoods. The project, which is still under construction in some areas, includes 1,300 acres of park space. The Beltline has catalyzed \$8B in private investment and has a goal of reaching \$10B by 2030. The Beltline is developing a comprehensive strategy to focus on creating and preserving affordable commercial space around the loop to encourage growth of small local businesses.



Source: Phillips, Gene

The Beltline in Atlanta, GA

LOOP, STITCH, AND RECONNECT

As the center of the entire state of Arkansas, Downtown Little Rock has always been at a crossroads of transportation and mobility. That said, Downtown is surrounded by barriers such as highways and railroads that make access difficult for those not using an automobile.

Improving transit connections to and within Downtown is critical for enhancing mobility and reducing the need for many underutilized parking lots. Additionally, making it easier to bike and walk to and within Downtown through wider sidewalks and new bike lanes will ensure that the district is accessible, safe, and enjoyable. Critical to this is enhancing the experience for bike and pedestrians on bridges into Downtown. Making these improvements to how people move around and through the city will ensure Downtown is better connected with the rest of the region and make it easier for people to get from where they are to where they need and want to go.

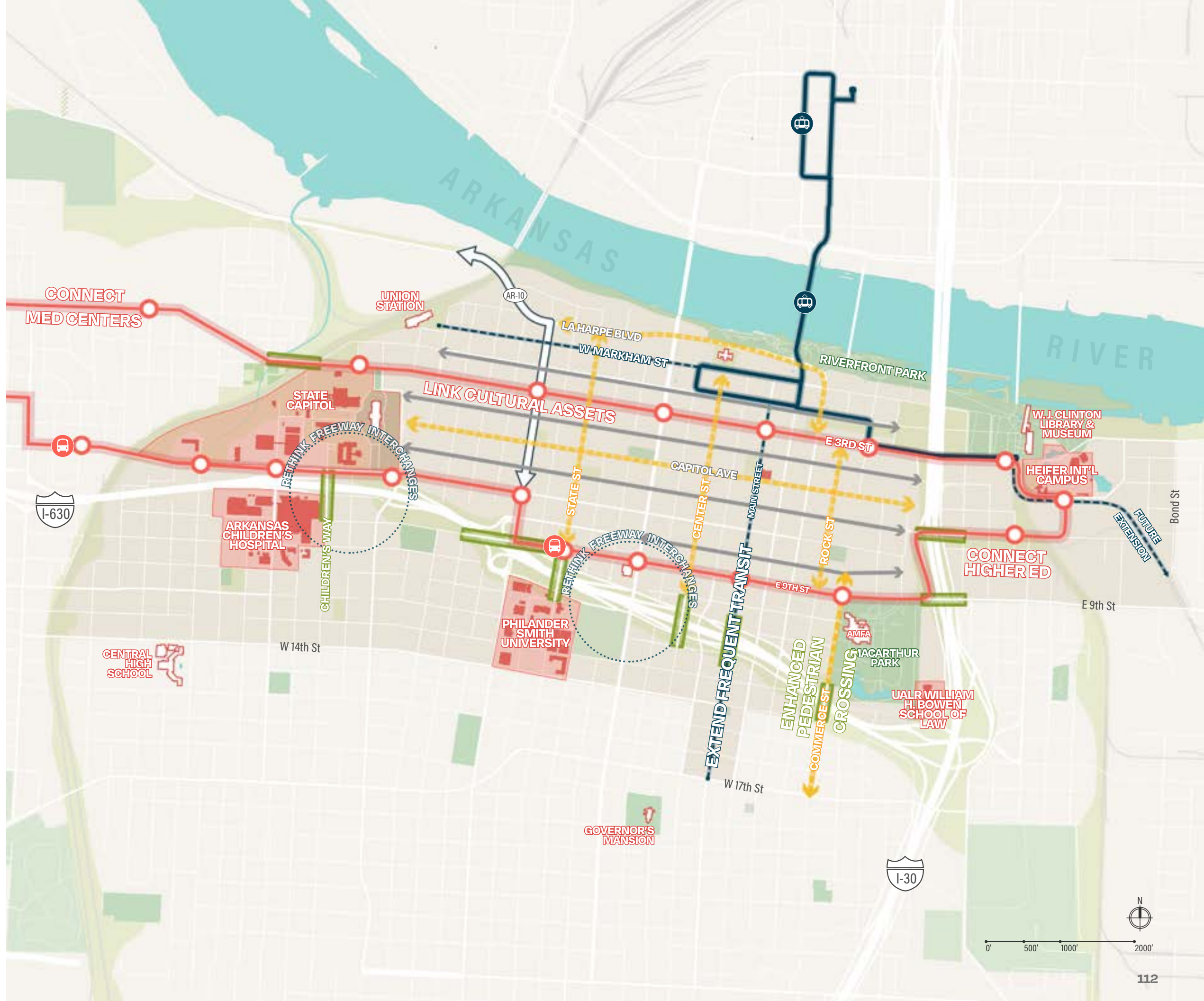

LEGEND

- Existing Trolley Line
- Proposed Trolley / Transit Expansion
- Proposed Bus Rapid Transit Route
- Proposed Bus Rapid Transit Stop
- Priority Road Diet
- Priority Two-Way Street Conversion
- Proposed AR-10 Re-Route
- Enhanced Pedestrian Crossing
- Existing Institutions
- Existing Open Space
- Proposed Open Space



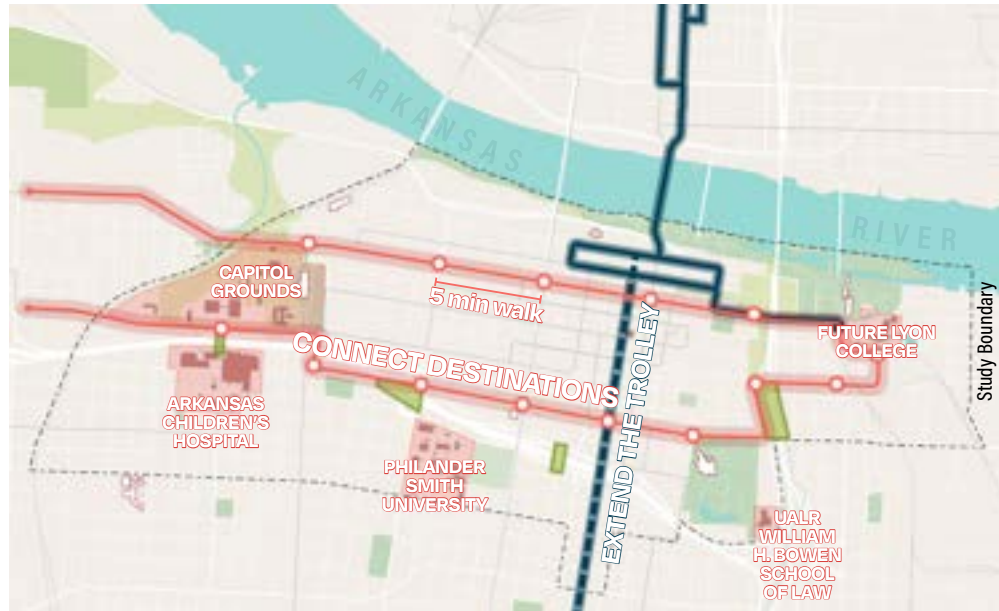

Rethink the Transit System

While downtown does have Rock Region Metro service, some areas are not easily accessible. Providing a new dedicated, high-frequency bus route and expanding the streetcar down Main Street to SOMA would better connect housing, job, and activity centers.



Streets become Place

Many of downtown streets are wide, underutilized, and unsafe for pedestrians and cyclists. Reimagining these streets by converting one-way streets to two-way and improving the walking and biking experience will create a people-first approach to streets.



Bridging the Divides

Downtown is shaped by the construction of interstates which destroyed entire neighborhoods when constructed. Reconnecting these areas through improved bridges and new parks can reconnect surrounding neighborhoods and address some of the damage caused.

CASE STUDIES

Health Line Cleveland, OH

The Health Line in Cleveland is one of the Nation's premier Bus Rapid Transit (BRT) systems. It connects downtown, medical centers, and educational institutions. The line operates 4 million passengers annually. It operates 24-hours per day and seven days per week. During peak travel times, it offers a 10-minute frequency service.



The Health Line

Kansas City Streetcar Kansas City, MO

This free-to ride line that opened in 2016 spans 2.2 miles through downtown from the River Market to Union Station and is funded by a Transportation Development District (TDD). The project cost a total of \$102M which was paid for with city Special Obligation Bonds, a 1% downtown sales tax in the TDD, a utility contribution, two federal grants, and \$20M in federal money from the Transportation Investment Generating Economic Recovery (TIGER) program. The project construction was delivered \$250,000 under budget.



Source: Guy, Jazz

Kansas City Street Car

The Cap - Union Station Columbus, OH

The Cap reconnects the urban fabric where it was divided by I-670 in downtown Columbus. The retail atop the bridge creates a seamless urban transition while also buffering noise from the highway below. The project opened in 2004 and cost \$7.8M dollars. It was funded mainly by private development that leveraged revenue from the 25,500 square feet of added retail.



Source: Skyscraper City











The Cap at Union Station

CULTURE AS A CATALYST

Downtown Little Rock has one of the highest concentrations of cultural amenities, museums, and institutions anywhere in Arkansas. The Arkansas and National history found in Downtown is profound and should be celebrated and better told. The many cultures and communities that comprise Downtown make it a melting pot unlike anything else in the State.

Many of these important destinations are isolated. Connecting these assets and communities to each other through partnerships and through physical connections will help to drive innovation and collaboration, creating a truly unique destination, which will in turn drive placemaking and growth. Central to this is the creation of a well-marked Cultural Loop, which will begin at La Petite Roche ("the Little Rock") and will connect key museums and heritage destinations along its path. Also critical is to reinforce Downtown as a center for higher-education, working to expand and enhance the presence of existing and new institutions within the Downtown core, bringing students to the area daily and serving to connect those students into the Downtown job market upon graduation.

LEGEND

-  Proposed Cultural Loop + Connections
-  Proposed Cultural Facility
-  Historic Quapaw Line
-  Culturally Significant Structures
-  Historic Districts
-  Existing Institutions
-  Existing and Proposed Trail Network
-  Enhanced Pedestrian Crossing
-  Existing Open Space
-  Proposed Open Space

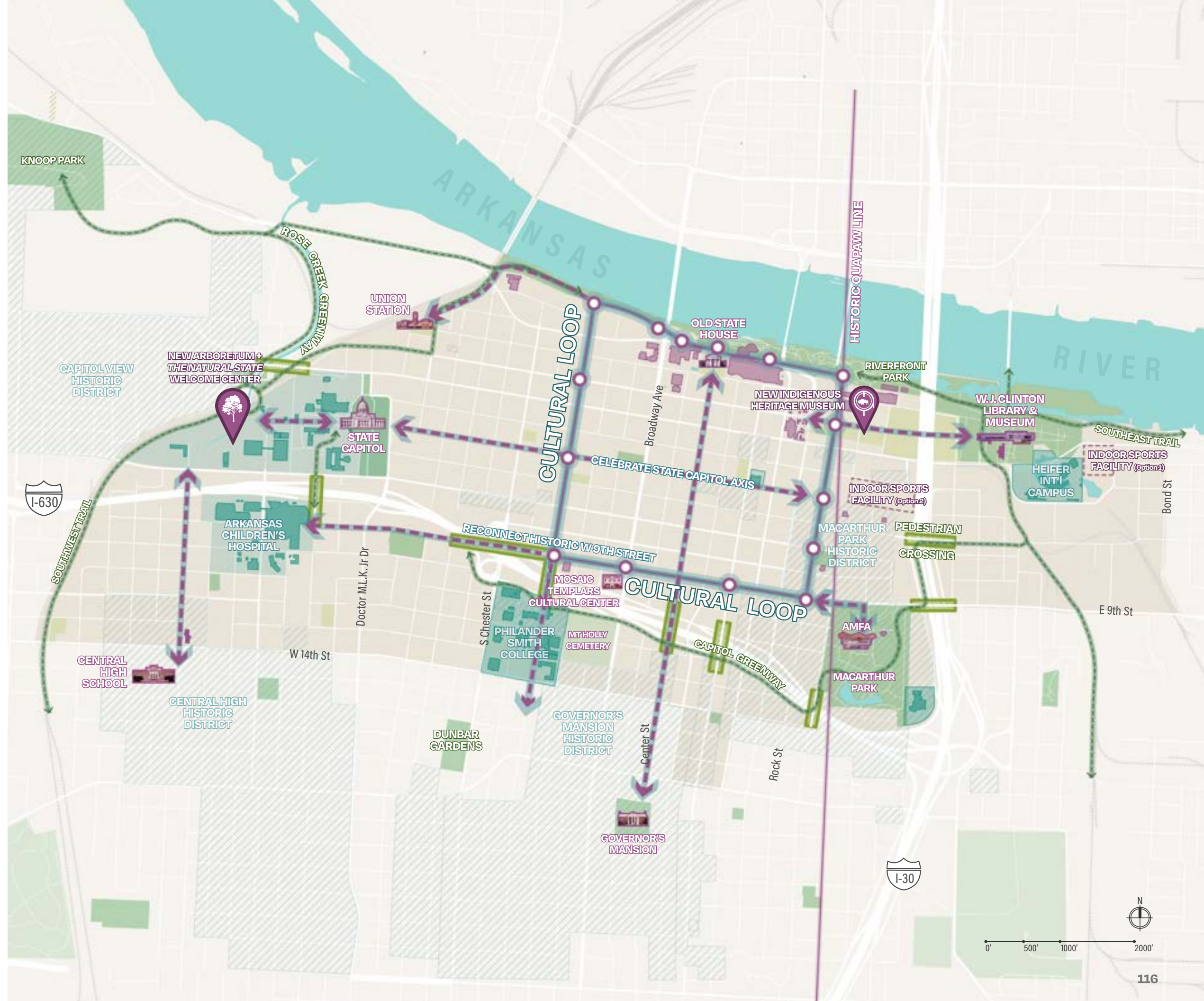

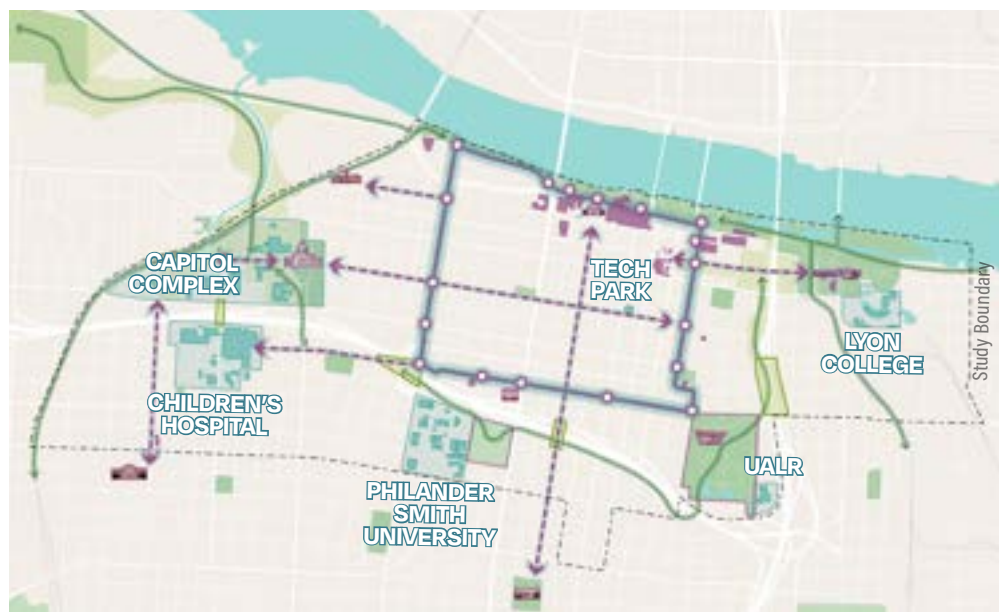
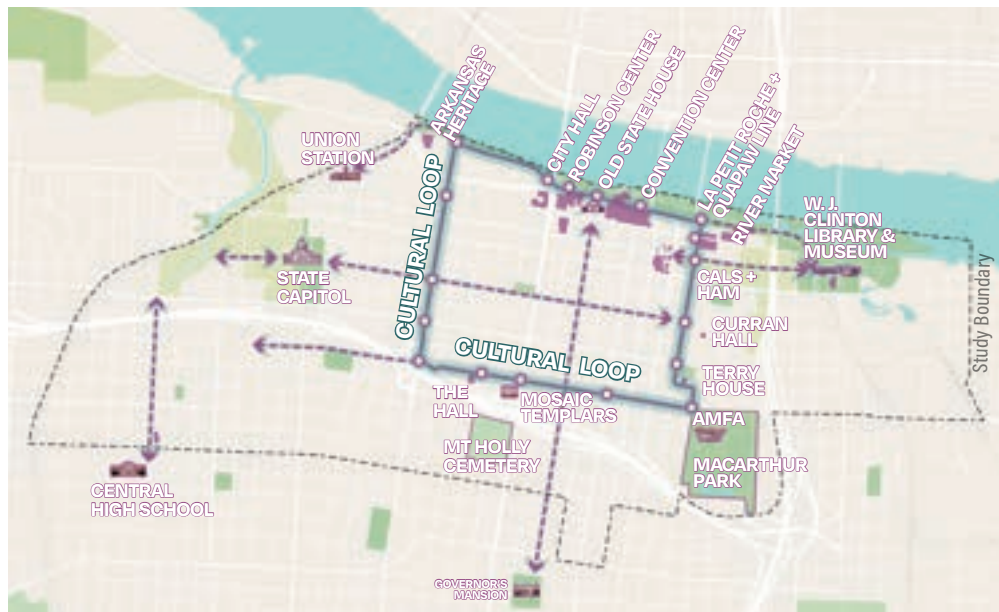
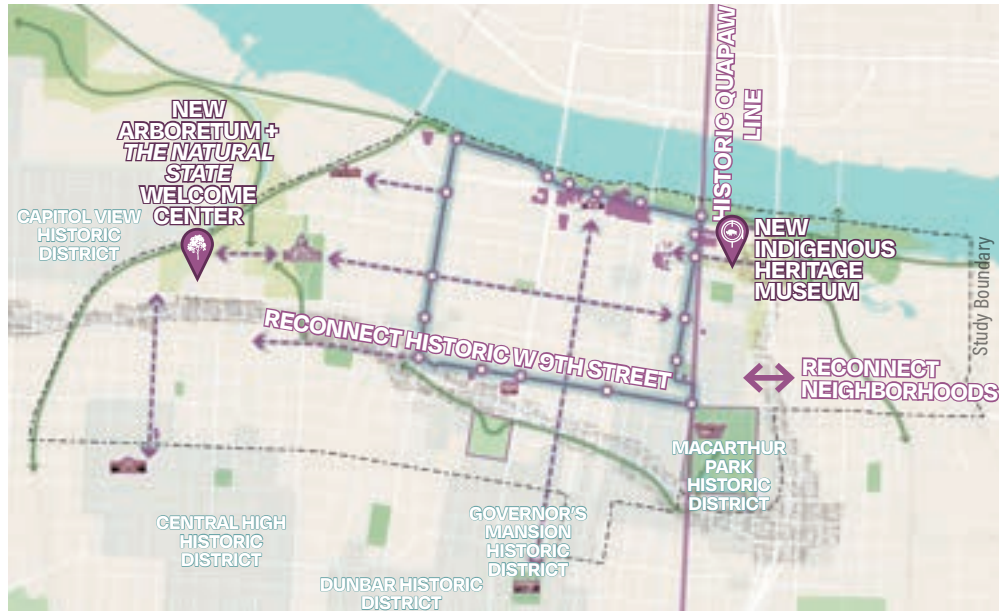

Remembering Past Histories

The land of downtown holds many traumatic histories of peoples' forced displacement from the Quapaw Line and Trail of Tears to the destruction of Historic Black Main Street. The city has the opportunity to confront this difficult past by bringing it to light.

A New Cultural Loop

Downtown Little Rock has numerous incredible cultural, institutional, and historical assets that are near each other yet feel very disconnected. A clear cultural trail marked with wayfinding could make movement between these assets easy and fun.

Celebrate Institutional Assets

Little Rock has numerous institutional, cultural, and historical assets that should serve as the centerpieces of the areas around them. Strategic and synergistic development can help frame and celebrate those spaces.

HISTORICAL CONTEXT

Downtown Little Rock, AR

I-30 and I-630 are both reminders of the ways in which infrastructure was used to physically destroy and separate communities. When these highways were built many decades ago, 83 city blocks and approximately 800 buildings were demolished. Downtown must better tell the stories of these lost neighborhoods and work to re-stitch the city and heal.



Downtown Little Rock, I-630 route

CASE STUDIES

Cultural Trail Indianapolis, IN

This 8.1 mile urban multi-use trail features a downtown loop and three spurs that connect cultural institutions in six downtown districts. The unique paving, street furniture, signage, and lighting visually unite the trail. The full project was completed in May 2013 at a total cost of \$63M. Funding came from philanthropy and federal transportation grants. A non-profit, the Indianapolis Cultural Trail Inc., manages and maintains the trail.



Source: Rundell Ernstberger Associates

Indianapolis Cultural Trail, IN

Texas State Capitol Austin, TX

The Capitol Complex Master Plan reinvisioned the capitol as a cultural and institutional amenity that is woven together by parks and civic space. Phase One was completed in 2022 and included new office space, underground parking, a tree-lined promenade, and three blocks of the Texas State Capitol Mall which is the northern gateway to the Capitol Complex. The mall offers spaces for every-day gathering and large events. The project cost is estimated at \$900M.



The Beltline in Atlanta, GA

THE VISION

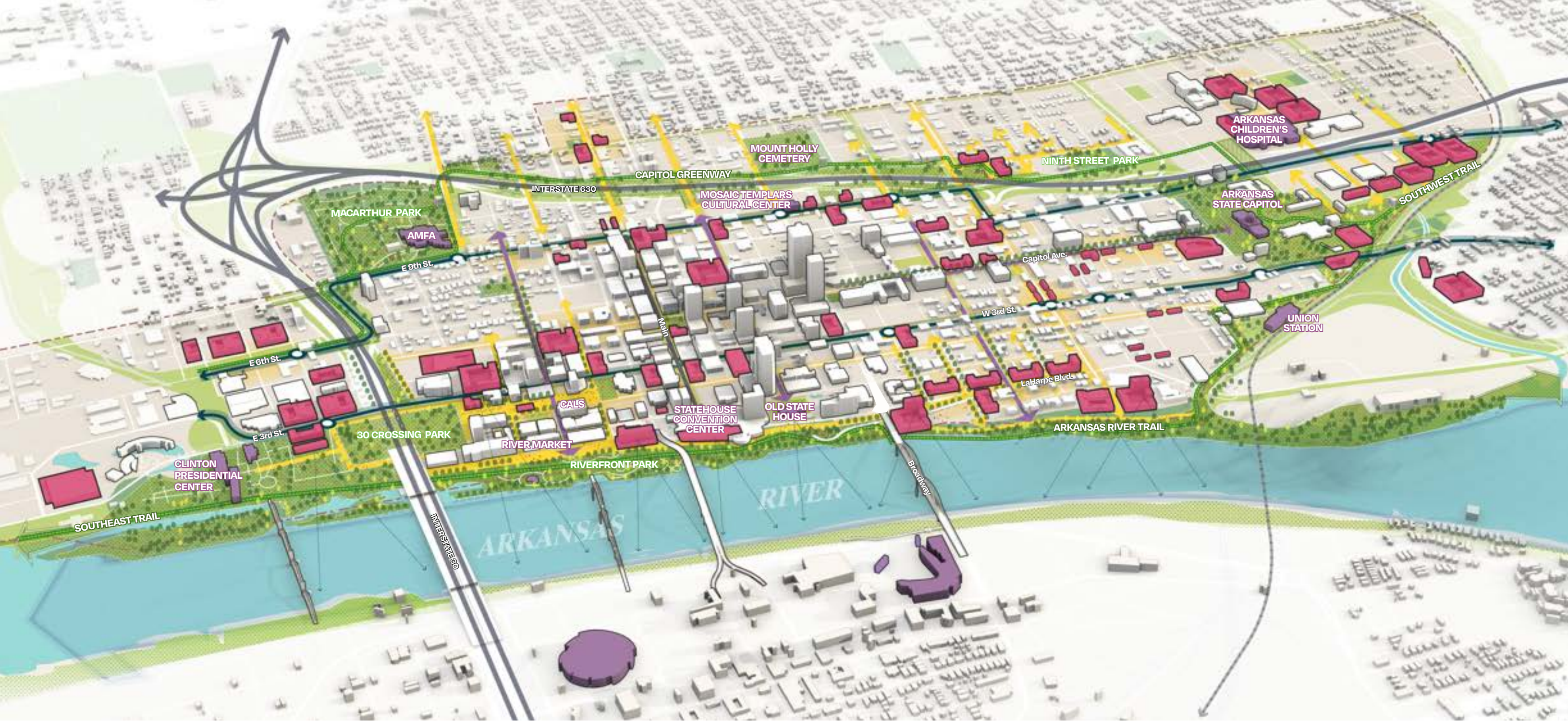

- Potential Infill Development
- Enhanced Open Space
- Enhanced Streets + Public Realm
- Existing/ New Trail Connections
- Proposed BRT Route

THE FRAMEWORK

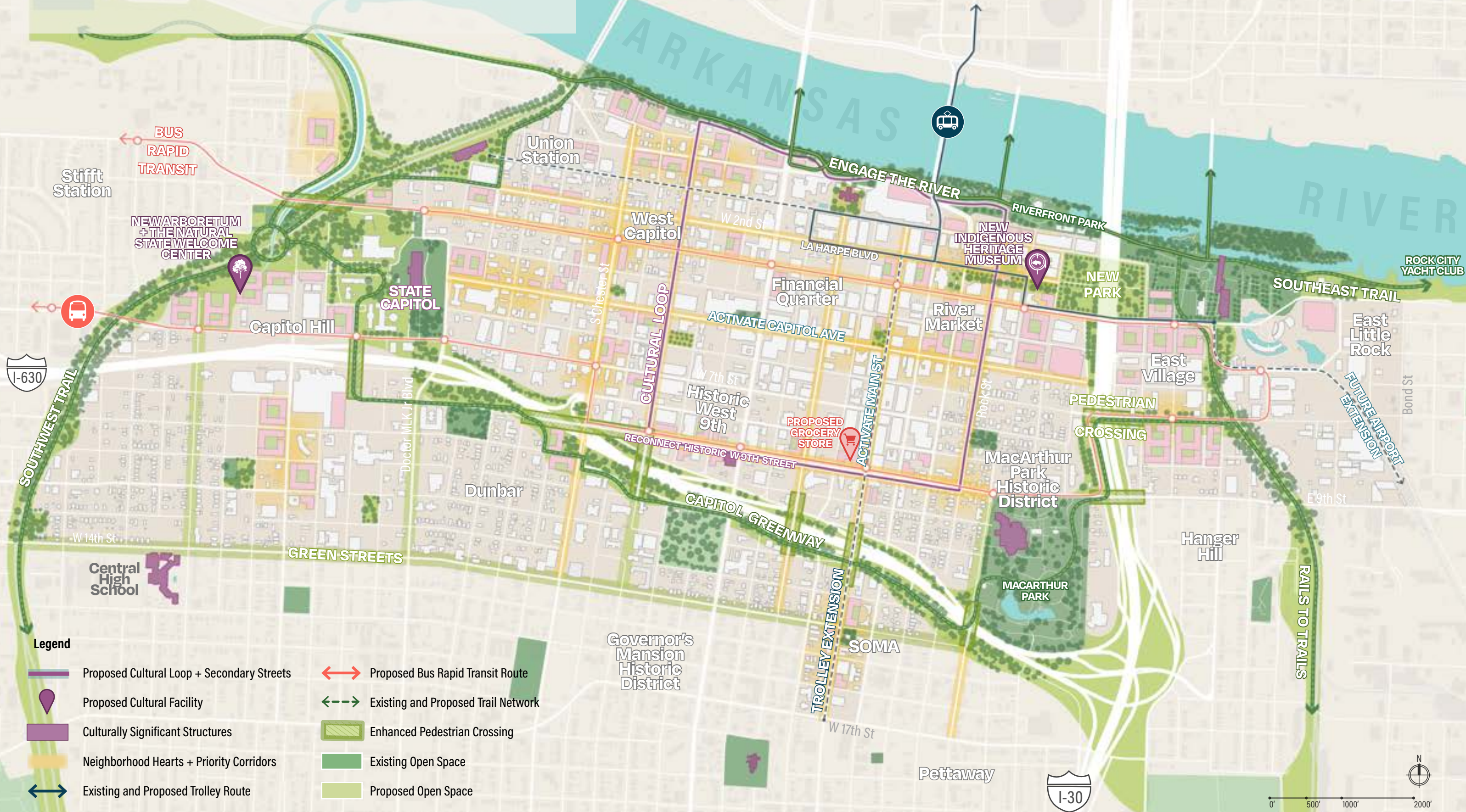

- Legend**
- Proposed Cultural Loop + Secondary Streets
 - 📍 Proposed Cultural Facility
 - Culturally Significant Structures
 - Neighborhood Hearts + Priority Corridors
 - ↔ Existing and Proposed Trolley Route
 - ↔ Proposed Bus Rapid Transit Route
 - - - Existing and Proposed Trail Network
 - ▨ Enhanced Pedestrian Crossing
 - Existing Open Space
 - Proposed Open Space

FOCUS AREAS

The four Big Ideas combine to create an overall framework for the Downtown Master Plan. Within that framework, sit four focus areas with tangible implementation strategies to bring the Big Ideas, Six Values, and the Vision Statement to life.

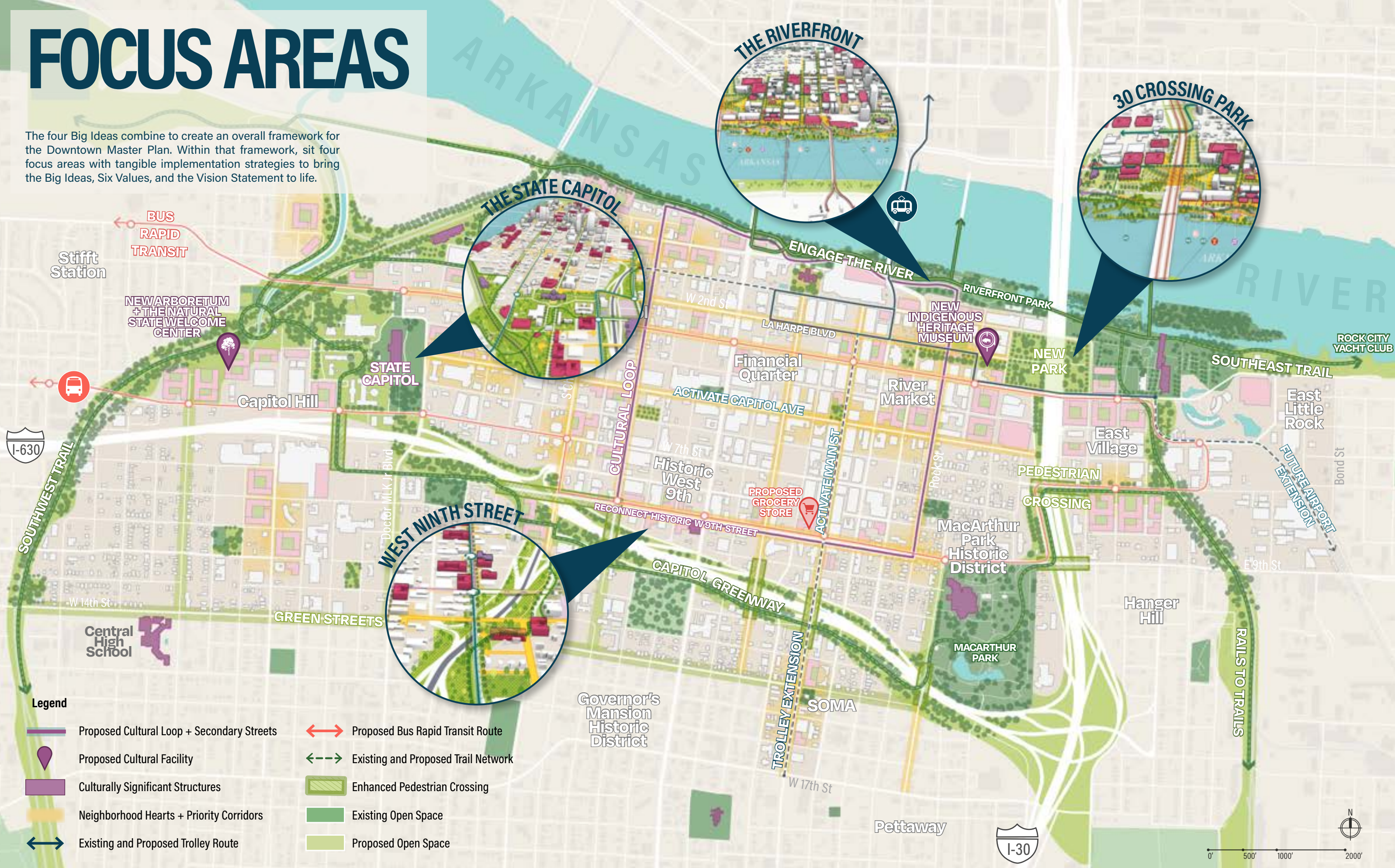

- Legend**
- Proposed Cultural Loop + Secondary Streets
 - Proposed Cultural Facility
 - Culturally Significant Structures
 - Neighborhood Hearts + Priority Corridors
 - ↔ Existing and Proposed Trolley Route
 - ↔ Proposed Bus Rapid Transit Route
 - - - Existing and Proposed Trail Network
 - Enhanced Pedestrian Crossing
 - Existing Open Space
 - Proposed Open Space

THE RIVERFRONT

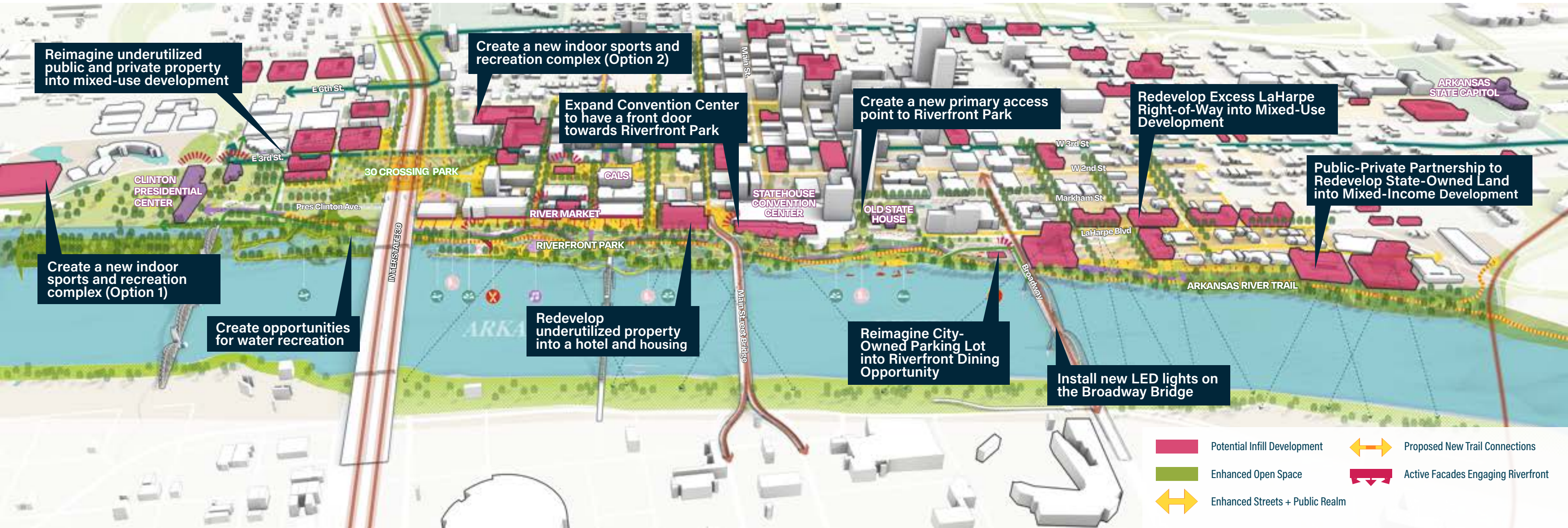

The Arkansas River defines Downtown Little Rock. Although the City has made improvements along the river's edge in Riverfront Park, the urban fabric of the city continues to turn its back towards the water. Reimagining the open spaces and development along the river is essential for unlocking success in the area and in creating high quality of life amenities to make living and working Downtown superior

to other neighborhoods in Central Arkansas. Key goals to achieve this include reimagining LaHarpe Boulevard as a slow, two-lane street, enhancing the facades of existing buildings near the river, and redeveloping publicly-owned land into mixed-use development to drive activity and vibrancy.



A reimagined waterfront for recreation and gathering next to the River.



New, enhanced access points and a reimagined LaHarpe Boulevard.

30 CROSSING PARK

Reimagine public parking lots into mixed-use development to help fund new park

Consider opportunities for celebrating Arkansas' Indigenous History

Reimagine public parking lots into mixed-use development to help fund new park

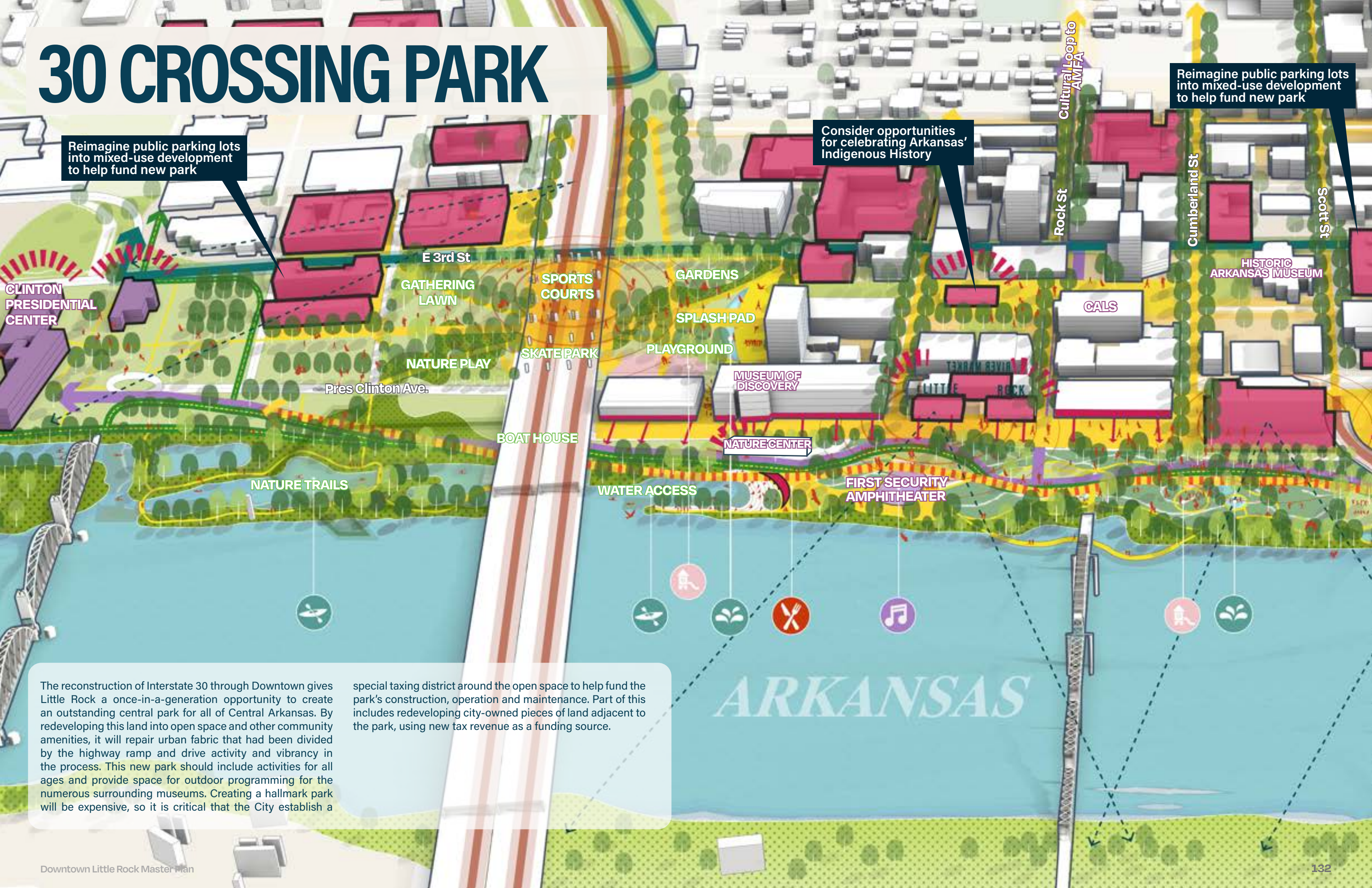

CLINTON PRESIDENTIAL CENTER

E 3rd St

GATHERING LAWN

SPORTS COURTS

GARDENS

SPLASH PAD

PLAYGROUND

NATURE PLAY

SKATE PARK

MUSEUM OF DISCOVERY

CALS

HISTORIC ARKANSAS MUSEUM

Pres Clinton Ave.

BOAT HOUSE

NATURE CENTER

NATURE TRAILS

WATER ACCESS

FIRST SECURITY AMPHITHEATER

The reconstruction of Interstate 30 through Downtown Little Rock gives Little Rock a once-in-a-generation opportunity to create an outstanding central park for all of Central Arkansas. By redeveloping this land into open space and other community amenities, it will repair urban fabric that had been divided by the highway ramp and drive activity and vibrancy in the process. This new park should include activities for all ages and provide space for outdoor programming for the numerous surrounding museums. Creating a hallmark park will be expensive, so it is critical that the City establish a

special taxing district around the open space to help fund the park's construction, operation and maintenance. Part of this includes redeveloping city-owned pieces of land adjacent to the park, using new tax revenue as a funding source.



New 30 Crossing Park at 2nd Street and Sherman Street

THE STATE CAPITOL

Capitol Avenue is a ceremonial street and mixed-use civic corridor connecting core of Downtown to State Capitol

Public-Private Partnership to Redevelop State-Owned Parking Lots into Mixed-Income Housing

Reimagine Marshall Street bridge with enhanced pedestrian and bike facilities

Connect State Capitol to the Arkansas River via Rose Creek Greenway and Southwest Trail

Public-Private Partnership to Redevelop State-Owned Parking Lots into Mixed-Income Housing

The Arkansas State Capitol anchors the western edge of Downtown and yet the grounds and the surrounding area is a sleepy area of parking lots and underutilized land. Planned and proposed trails have the potential to transform the Arkansas State Capitol grounds into the epicenter of the Central Arkansas regional greenway network. By reimagining excess State-owned property as public open space, outdoor educational space, and private development opportunities, the State Capitol can reinforce itself as an anchor on the western edge of Downtown. The plan imagines the grounds as a space for recreation, living, working, and playing that connects people to nature and reinforces it as the center of The Natural State.

WEST NINTH STREET

A new Black Entrepreneurship and Incubator Hub could be built on existing surface parking lots

West 7th and Chester has existing assets and should be reimaged as a neighborhood heart

The State Street Bridge should become a pedestrian-only bridge connecting Philander Smith to West Ninth

Excess ARDOT right-of-way should be transformed into a cultural memorial space

Public-Private Partnership to Redevelop Excess ARDOT right-of-way into Affordable Housing

West Ninth Street was historically Little Rock's Black Main Street. Unfortunately, its significance was destroyed by the construction of Interstate 630 many decades ago. Building off key anchors such as the Mosaic Templars Cultural Center and The Hall, West Ninth Street should once again become a cultural spine, anchoring the southern end of Downtown while connecting key assets such as the Arkansas Museum of Fine Arts to Arkansas Children's Hospital. Strategies

for the area should include the creation of a new Black Entrepreneurship and Incubator Hub, the reconstruction of the roadway with robust public realm as a part of the proposed Cultural Loop, new infill development, and enhanced bridge crossings over the interstate. Long-term, a new deck park should better connect the two sides of the interstate, and a new bridge for West Ninth Street should be built to reconnect the divided street.

MOSAIC
TEMPLARS
CULTURAL
CENTER

THE HALL

MOUNT HOLLY
CEMETERY

PHILANDER SMITH
UNIVERSITY

RECONNECT HISTORIC WEST NINTH STREET

NINTH
STREET
PARK

5

Implementation



FROM VISION TO REALITY

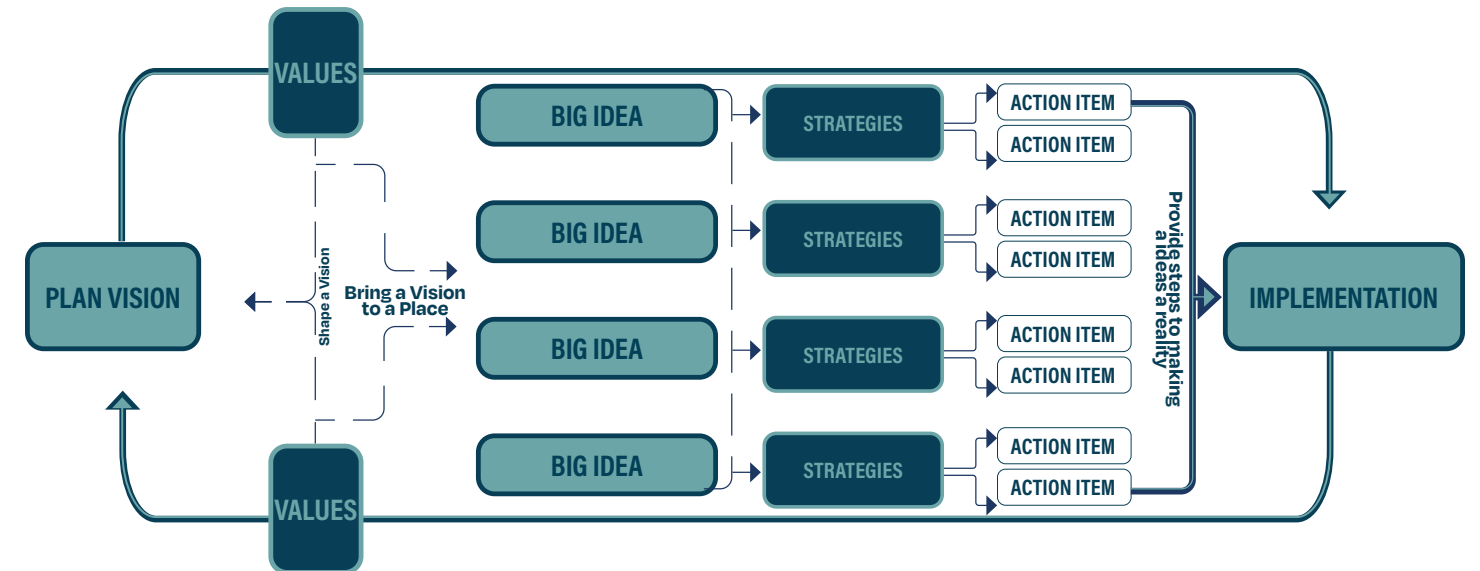

In 2023 the City of Little Rock, in partnership with the Downtown Little Rock Partnership, engaged for the first time ever in a process to prepare a comprehensive Downtown Master Plan. The sponsors recognized the need for a plan to guide the many downtown stakeholders who, by working collaboratively, will guide the implementation strategy to achieve the vision laid out in this plan.

The Master Plan will serve many purposes, but most importantly it is a guide and playbook to coordinate the decision-making of the myriad of public, private, institutional and community stakeholders who will be vital to realizing the master plan vision.

The Master Plan is organized by Projects, Policies, Programs and Partnerships (i.e., the Four P's) that provide the foundation for the four Big Ideas and through their implementation will achieve the transformational goals for downtown.

The adage that “to plan is sublime...to implement is divine” is a guiding tenet for successful and effective downtown planning and will be the ultimate measure of a success for the efficacy of this Plan. In downtown master planning, implementation is both a noun and verb. The Downtown Little Rock Master Plan document is the noun while implementation of the plan is the verb.

Master Plan implementation was considered from the beginning of the planning process with the Four P's and their related four big ideas as transformational actions in derived from the vision and values of the plan.

The Master Plan is guided by the vision and values developed during the planning process and as described in the Executive Summary and are foundational to the Four P's which are the focus of the implementation strategy for downtown. The Implementation Strategy is a necessary

set of coordinated immediate, short, medium, and long-term actions that utilize the projects-policies-programs-partnerships (4 P's) to achieve the four Big Ideas identified in the Master Plan, and to guide and coordinate the public, private, institutional and community stakeholder decision-making necessary to achieve the vision of the plan.

The implementation strategy will require on-going attention and maintenance by the City and Downtown Little Rock Partnership with specific focus on:

1. **Evolving the Vision:** The plan establishes a “first-ever” vision for the future of Downtown, with coordinated implementation actions that can be taken immediately and over the mid-and and long-term. The plan will accomplish little by itself but will be highly-effective if used as a guide by the key stakeholders such as the Downtown Partnership, the City of Little Rock, and the many other private, institutional and community stakeholders.
2. **Ongoing Stakeholder Participation:** Because the Downtown Master Plan was shaped by the aspirations, goals, and concerns of a broad array of stakeholders, there should be ongoing engagement opportunities to assist in evolving and enriching the plan and its outcomes
3. **Public Interjurisdictional Coordination:** Implementation will require cooperation and coordination between city departments, state, federal, and adjacent municipalities for successful implementation and for efficient allocation of public resources. Pooling and sharing resources between public jurisdictions can leverage cost-effective private investment.
4. **Public-Private-Institutional Partnerships (P3):** Master Plan implementation will require new partnerships and collaborations between the City, private developers,

MAKING IT HAPPEN

investors, and local institutions and other complementary stakeholders for development of the types of projects identified in the Plan. For example, achieving the recommendations laid out in this chapter will require intentional actions by existing and new public-private-institutional partnerships.

- 5. **City of Little Rock Inter-Departmental Coordination:** The guidance of city leadership, through dedicated resources and support, is vital for Plan implementation. City government is organized by departments that need to work cooperatively to remove obstacles to Implementation. Coordination and communication between these departments, including the City of Little Rock Planning + Development, Parks & Recreation, Public Works, and Housing Department, is necessary



to accelerate key projects that will demonstrate immediate changes in downtown and begin to change the perception of Downtown as a place for private and institutional investment.

- 6. **Master Plan Management and Ownership:** The Implementation Committee outlined on the following page should be tasked with formalizing an ongoing master plan sponsor with "ownership" responsibilities to lead, manage and coordinate implementation recommendations and actions.
- 7. **City of Little Rock Land Use and Regulatory Actions:** Arkansas state law gives the City the power to regulate Downtown land uses with zoning, subdivision, and development regulation tools unique to the city. These tools need to be reviewed over time to identify obstacles and opportunities to support the implementation of Plan recommendations. Some of the strategies identified in the Plan can be implemented through zoning



and development policy changes that are currently hindering rather than supporting the type of Downtown development called for in the plan.

- 8. **City Capital Improvement Program:** The City has a capital improvement program and budget that should be coordinated with the Master Plan to ensure that resources are available for proposed projects. It should be recognized that the city owns a substantial amount of land which can be used as capital-financing to assist with advancing implementation of the projects identified in the plan.

THE IMPLEMENTATION COMMITTEE



The establishment of a dedicated Master Plan Implementation Committee is essential for its successful implementation. Although not listed as a specific strategy, we would recommend that it is the most essential first action for the entire plan. This committee should convene immediately upon adoption of the Master Plan and begin to identify key actions and tasks to achieve the immediate and short-term actions that are outlined in this chapter. The committee should be a lean, nimble team of decision-makers and leaders that are capable of executing action items through their roles. The proposed committee structured outlined below is envisioned to meet monthly, advance strategic items, and monitor progress annually. The committee should be co-chaired by the Executive Director of the Downtown Partnership and the future Director of a proposed Downtown Development Corporation, once that institution is constituted. As such, its constitution should be a high priority for the Implementation Committee in the short-term.

RECOMMENDED COMMITTEE STRUCTURE

Committee Co-Chairs

Executive Director
Downtown Little Rock Partnership

Future Director
Downtown Development Corporation

Elected Officials

Mayor
City of Little Rock

Director - Ward 1
City of Little Rock

Leadership Positions

President
LRCVB

CEO/President
LR Regional Chamber

Director
Metroplan

Additional Members

Planning and Development Director | City of Little Rock

Parks and Recreation Director | City of Little Rock

Public Works Director | City of Little Rock

Housing Director | City of Little Rock

Board President | Downtown Little Rock Partnership

President | Downtown Neighborhood Association

*Non-voting members from City/DLRP-hired consultants could sit on the Committee and serve to coordinate meetings, as needed.

THE 4 Ps

- Projects** (Icon: Hammer) Projects are undertakings that result in permanent physical changes. These are often seen as a catalyst to, or result of, development that affects the built environment.
- Policies** (Icon: Document) Policies define requirements and incentive programs to control and influence future changes. They are physically immaterial but affect real-world change.
- Programs** (Icon: Gear) Programs are actions taken to control and influence elements of the Study Area but do not require permanent physical changes. These are tools that can help to generate revenue and maintain investments.
- Partnerships** (Icon: Handshake) Partnerships are arrangements between public, private, and/or non-profit entities to collaborate on the delivery of a desired outcome.

HOW TO USE THIS CHAPTER

The Implementation Chapter is the roadmap to success for the Downtown Little Rock Master Plan. Its 4 Big Idea, 12 Goals, and 45 Strategies are a comprehensive set of projects, policies, programs, and partnerships that, when enacted over time, will enable the vision for Downtown to become a reality.

Each Big Idea is comprised of four goals. Though numbered, these goals are not prioritized, as each is of equal importance. Each Goal has a Goal Metric, which is a quantifiable measure to annually track progress. The Implementation Committee and the Downtown Little Rock Partnership should be responsible for monitoring these metrics. Each Goal has a series of two to four Strategies, each with its own lead implementer, potential partners in implementation, timeline for implementation, potential funding sources or strategies, and key action steps. Just like the Goals, the Strategies are not ranked in order of importance.

The Roadmap on the next page is a simplified means of understanding how some of the Strategies interact with each other, including how some will require certain Strategies to occur prior to their implementation. Most critical for the success of the entire plan is establishing Tax Increment Financing (TIF) as a tool to finance the many public and private actions laid out on the following pages.

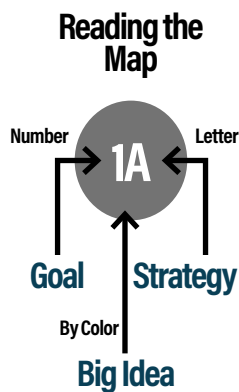
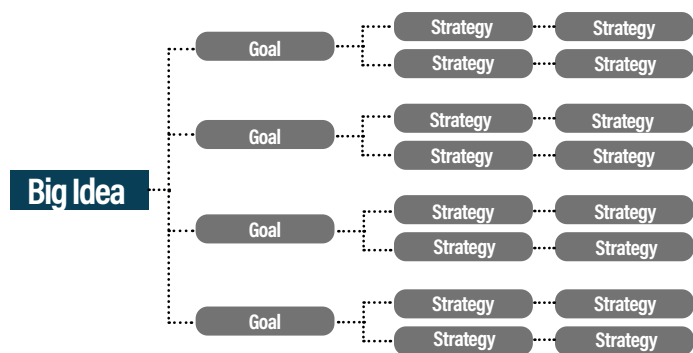

- 1A** A Tapestry of Neighborhoods
- 1A** Loop, Stitch, and Reconnect
- 1A** Rambles to the River
- 1A** Culture as a Catalyst

THE ROADMAP

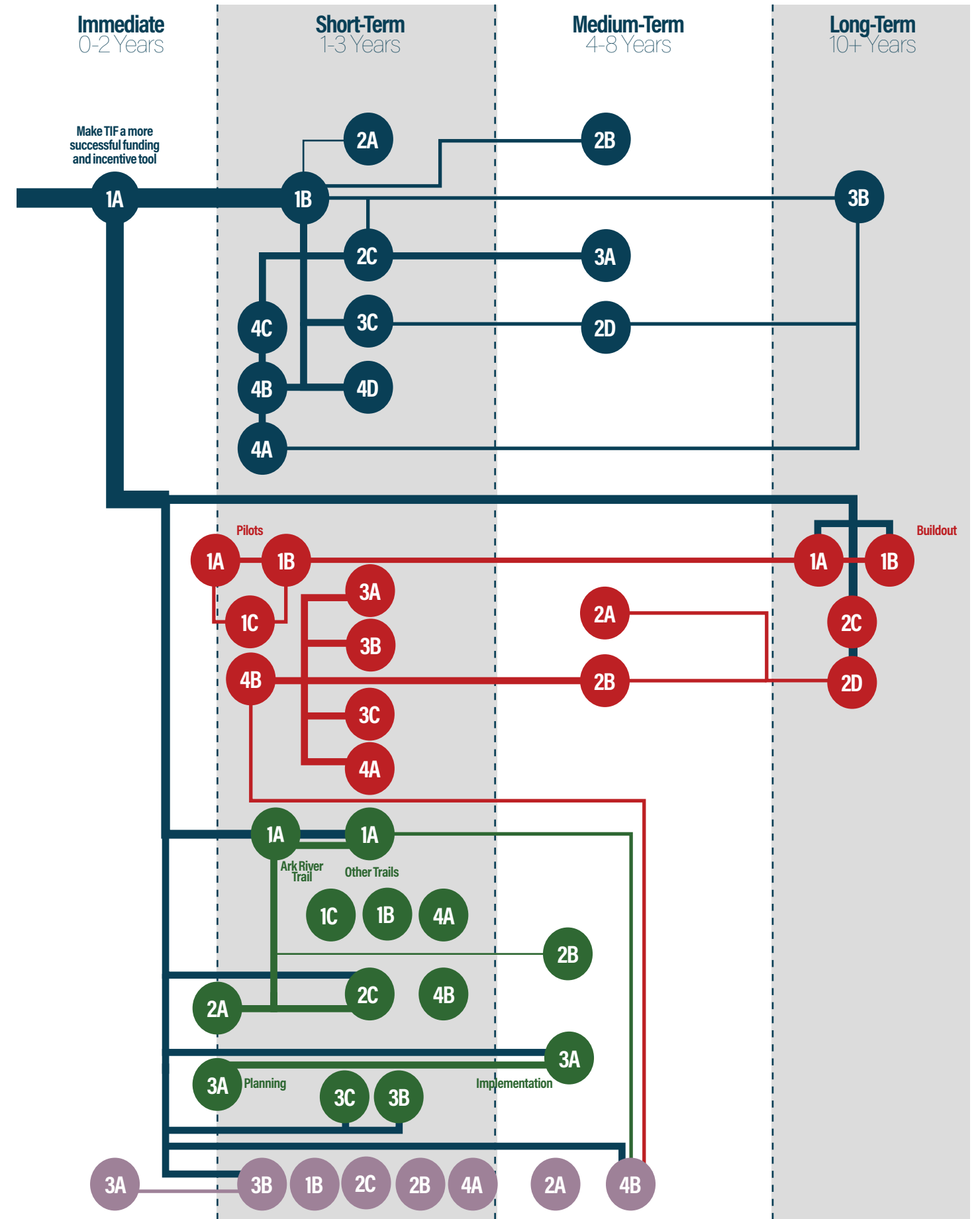

THE GOALS

A Tapestry of Neighborhoods

1

GOAL Develop organizational changes and financial incentive tools to coordinate implementation and aid in the delivery of new development

METRIC Amount of private investment catalyzed by public investment

3

GOAL Establish Downtown as a livable neighborhood, with high quality of life and amenities

METRIC Number of residents living Downtown

2

GOAL Establish Downtown as a vibrant residential district, doubling residential population by 2035.

METRIC Number of residential units delivered annually

4

GOAL Make appropriate regulatory changes to reduce barriers for new development downtown

METRIC Total square feet of new development delivered Downtown annually

Culture as a Catalyst

1

GOAL Change perceptions of Downtown through reimagined promotion and branding

METRIC Perceptions of Downtown survey results

3

GOAL Establish Downtown as a regional center for higher education, innovation, and entrepreneurship

METRIC Number of new businesses opened annually; number of students learning downtown; value of annual investment in small businesses annually Downtown

2

GOAL Establish Downtown as an epicenter for regional events and culture.

METRIC Number of public events and/or attendance at public events Downtown annually

4

GOAL Improve connections and collaboration between key historic and cultural assets

METRIC Miles of Cultural Loop completed

Loop, Stitch, and Reconnect

1

GOAL Enhance transit mobility within downtown to make downtown a park-once district

METRIC Percentage of residents in Downtown Little Rock commuting via transit

3

GOAL Prioritize pedestrian and bike safety and connectivity within downtown by reimagining how existing roadways function

METRIC Number of bike and pedestrian collisions Downtown annually

2

GOAL Improve pedestrian and bike connectivity into downtown.

METRIC Percentage of residents in Downtown Little Rock commuting via biking or walking

4

GOAL Reimagine key roadways as green streets to connect people to parks and open spaces

METRIC Miles of new bike lanes and sidewalk improvements installed annually

Rambles to the River

1

GOAL Create an interconnected network of trails

METRIC Number of miles of trails constructed annually

3

GOAL Reimagine the Arkansas River frontage to create an active urban waterfront.

METRIC Estimated number of visitors to the Arkansas Riverfront annually

2

GOAL Develop new parks and open spaces to improve daily quality of life

METRIC Estimated number of visitors to downtown parks annually

4

GOAL Utilize infrastructure enhancements to improve sustainability and resilience of Downtown

METRIC Number of new trees planted in Downtown annually



Strategy 1A

Make Tax Increment Financing a more successful funding and incentive tool for driving investment Downtown

Lead Implementer:	City of Little Rock; Downtown Partnership; State of Arkansas
Other Groups:	None
Timeline:	Immediate (0-2 Years)
Funding Sources:	No Funding Required

1

2

3

Collaborate with State government to amend regulatory barriers within State TIF law and Tax Abatement laws to maximize potential value capture for TIF.

Advocate and champion the passing of a State Constitutional amendment in the future.

Establish a Downtown Little Rock TIF District/s to assist in financing infrastructure and other enhancements. At least one TIF district boundary should include existing Metrocentre BID boundary along with additional areas.

One of the most obvious and critical issues for successful revitalization of Downtown Little Rock is the need for new financial incentives to assist private development and the construction of public infrastructure. Currently no such incentives exist at the City-level (various state and federal tax credits do exist).

The two most viable tools to assist in redevelopment are tax increment financing (TIF) and tax abatements. Both have restrictions in state law (millage limits and prohibited by state law respectively). Collaborating with State lawmakers and with other advocacy groups around the state is critical in working to advance state law and constitution changes necessary to make these tools more viable. Those conversations are ongoing and should be the highest priority in the first two years of implementation. The most critical amendments to State TIF law are: 1) expanding the total millage that can be collected by the TIF, and 2) expanding the range of eligible uses for TIF funding beyond those related to public infrastructure, including land acquisition, property assembly, site preparation, and other private development costs.

Regardless of the outcome of that lobbying effort, TIF is still a tool that should be leveraged. Creating a new TIF district or districts strategically located around catalytic areas within downtown will create a revenue stream for assisting private development financing and in public infrastructure delivery. This will help to provide gap financing for private development, giving the City a tool

to attract new development, particularly housing. The current Metrocentre Business Improvement District (BID) generates little revenue. While the entity exists in perpetuity, it can be dissolved after 2025. Due to the BID's low revenue generation, the Downtown Little Rock Partnership is largely subsidized by the City of Little Rock. This model is financially unsustainable and an alternative model is needed.

The best strategy for the Downtown Partnership is to both reimagine how the partnership is funded and how it will operate. In conjunction with the creation of a new Downtown TIF district, a new Downtown Development Corporation should be created to be the economic development arm of the Downtown Partnership. This new Downtown Development Corporation should be the entity that manages the TIF district, while also managing economic development and planning within Downtown since that capacity does not exist at City Hall. In addition to TIF, this new entity should manage other economic development tools and strategies, including land acquisition and disposition, site assembly, and public/private partnerships.

Once a new TIF district is created in Downtown, annual increment will be generated. A small portion (the administrative fee) of that increment can be used annually as a sustainable funding stream for the entity that operates and manages the TIF. The new Downtown Development Corporation's operations should be financed via this portion of the TIF increment revenue.



Strategy 1B

Establish a Downtown Development Corporation that manages incentive tools and advances development goals

Lead Implementer:	City of Little Rock; Downtown Partnership
Other Groups:	None
Timeline:	Short Term (1-3 Years)
Funding Sources:	Funding derived from Administration fee from newly created TIF district, development impact fees, philanthropic donations, and public land sale/leases.

4

5

6

Leverage a portion of the annual TIF District revenue to fund a reimagined Downtown Partnership which operates as a Downtown Development Corporation that plays a bigger role in redevelopment, economic development, management, and planning in Downtown.

Within the new development corporation, create two new staff positions, one solely focused on planning/urban design strategy and another focused on economic development implementation, including management of the newly created TIF District.

Consider retiring the existing Metrocentre BID only when a successful TIF district is established and is generating ample increment.

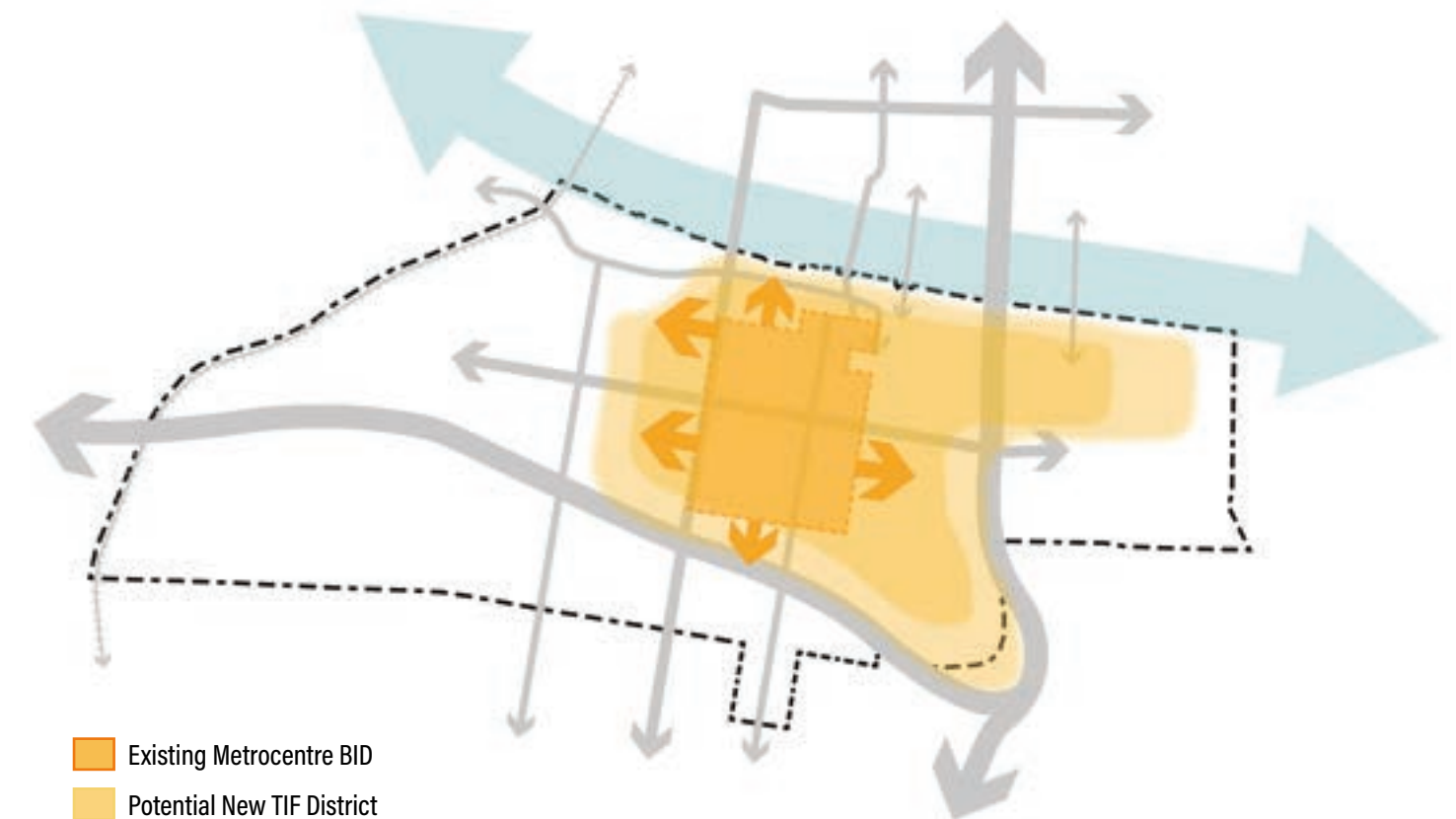



Strategy 2A

Redevelop the River Cities Transit Center into a mixed-use, mixed-income multifamily development

Lead Implementer:	Rock Region Metro
Other Groups:	City of Little Rock Planning and Development; Public Works; Housing
Timeline:	Short Term (1-3 Years)
Funding Sources:	USDOT RAISE Grant; Metroplan STBG Grant (for street reconstruction); TIF Financing (once TIF is established)

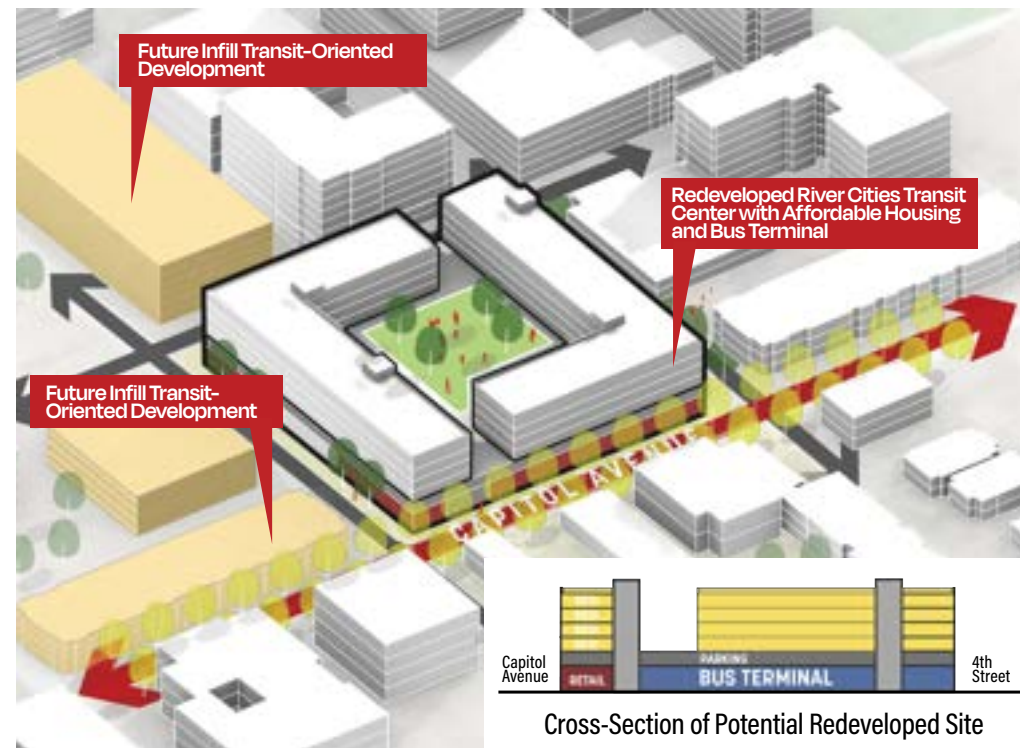

Rock Region Metro is exploring opportunities for reimagining their River Cities Transit Center as a mixed-use transit-oriented development that could continue to provide transit service while also providing ground-level retail, commercial spaces, amenities for daily needs, and multifamily rental at a range of affordability levels. Ongoing work and coordination between Rock Region Metro and the City on this redevelopment should be prioritized as the site sits at a critical junction between Main Street and the River Market, and adding new development to the site will help to connect the two areas. Redevelopment will require further design study and community engagement for a final design to be advanced.

Case Study

La Crosse, Wisconsin

La Crosse, Wisconsin (pop. 52,000) received federal grants to help fund a mixed-use bus terminal with 8 bus stalls, 15,000 square feet of retail, and 92 mixed-income apartments. All bus operations occur in a covered bus terminal beneath a level of structured parking and four levels of apartments.



Source: IMEGCorp.com



Strategy 2B

Reimagine existing underutilized office towers, such as the Donaghey Building and Tower Building, as mixed-use adaptive reuse office to residential conversions

Lead Implementer:	Private Development
Other Groups:	Development Corporation (to be established); City of Little Rock Planning and Development; City of Little Rock Housing
Timeline:	Medium Term (4-8 Years)
Funding Sources:	State Historic Tax Credits; Federal Historic Tax Credits; TIF Funding (to be established)

Numerous office buildings in Downtown Little Rock have low occupancy or are entirely vacant. Due to the time and costs required for delivering new construction, renovating these existing towers into opportunities for housing is an incredible opportunity to provide additional housing stock in the core of the City. It will help to right-size the office market by removing available space while also providing demanded residential product in the heart of activity. These renovations have already successfully occurred in several Downtown office buildings.

Two of the most notable office towers that should be prioritized for conversion are the Donaghey Building and the Tower Building. Due to their floorplate sizes, both are well-positioned for conversions into apartments. While

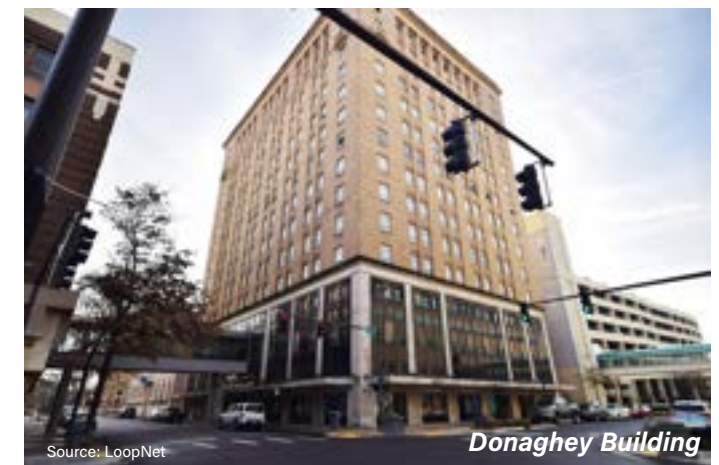

Source: LoopNet

Donaghey Building



Source: LoopNet

these two towers, and others, are indeed opportunities for new residential units, the costs associated with renovating office spaces into residential can be higher than the current market rents will permit. State and Federal Historic Tax Credits are available to provide some, but potentially not all, of the necessary gap financing that would be needed for renovation. As such, additional incentives tools will facilitate the renovation of these and other buildings.

One potential tool, as outlined in Strategy 1A, is to leverage future tax increment generated through the creation of a new TIF district to pay for various costs. Currently, TIF financing could only be used to pay for public realm and infrastructure enhancements, but should the State law be changed in the future, additional costs could be covered by TIF financing, including building acquisition by the proposed development corporation and costs associated with affordable housing. Other tools such as tax abatements could also assist in easier delivery of renovating existing towers into residential units.

Strategy 2C

Identify key underutilized city, county, and state-owned parcels and pursue redevelopment through public-private partnerships into affordable housing and mixed-use development

Lead Implementer:	City of Little Rock, Pulaski County, State of Arkansas
Other Groups:	Downtown Partnership; Development Corporation to be established; LRPD; City of Little Rock Housing; Arkansas Development Finance Authority
Timeline:	Short term (1-3 Years)
Funding Sources:	No funding required. Additional funding mechanisms such as LIHTC could be explored for affordable housing and TIF Financing, once TIF is established

How Does Public Land Disposition Work?

- 1 The City or other public entities identify underutilized properties with the potential to redevelop and identify development partners through a request-for-proposal (RFP) process. RFPs can include requirements such as types of development, affordable housing and improved urban design.
- 2 Developers submit proposals for how they would develop that property.
- 3 Public entity selects the preferred winner that best meets the criteria outlined in the RFP.
- 4 Sale or lease-back of public land for below-market-value price reduces development costs, making new, denser development more financially viable.
- 5 Property is redeveloped, contributing to new development downtown.

Although the City of Little Rock currently does not have any financial incentives to offer private development, they do own numerous parcels of underutilized land that could be sold or leased to private development at a far-below-market-rate, helping to cover some or all of the financial gap that currently exists in projects Downtown. Across Downtown, there are hundreds of acres of public land. And while many are unavailable due to their current land uses, the City and other public entities should evaluate their current property holdings in order to determine opportunities for disposing of underutilized assets. Several key sites that should be considered for disposition soon are highlighted to the right.

Potential Opportunities for Land Disposition

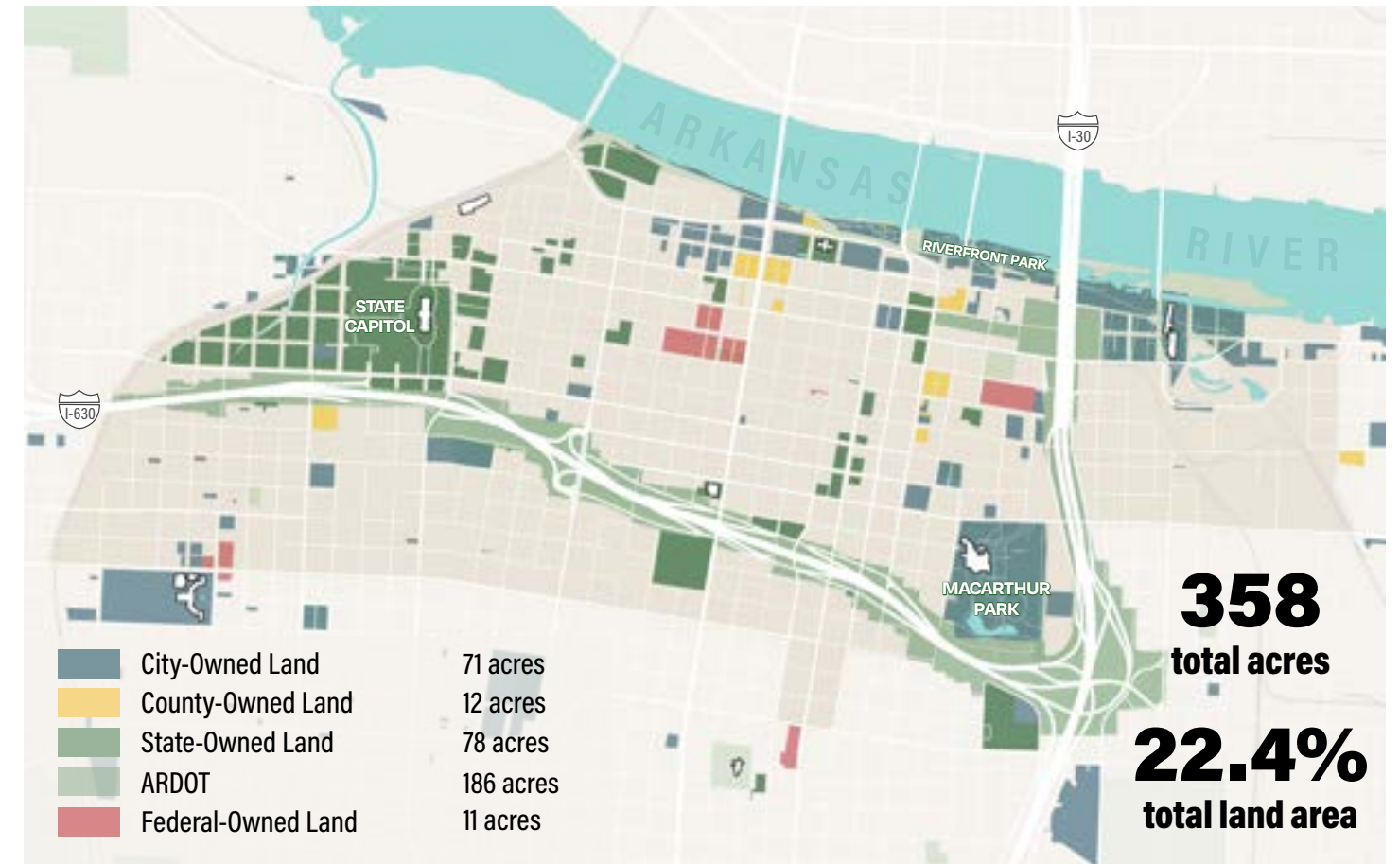

Case Study 9th Street and Main Street

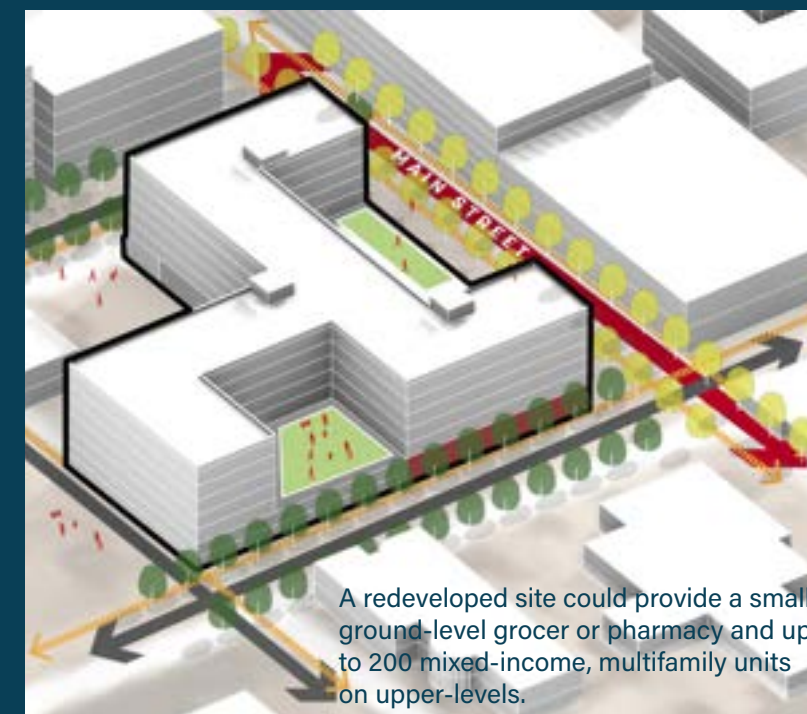

The Arkansas Development Finance Authority, a State-run Agency responsible for financing affordable housing, owns 1.5 acres of surface parking at 9th and Main Street. The parking provides weekday parking for nearby State offices.

The Downtown Little Rock Partnership owns and manages a nearby public parking garage. That garage is, on average, 25% utilized, with 400+ spaces available daily.

The existing parking needs can be parked in the public garage through a new partnership, freeing up the land for redevelopment.

Public-private partnership to redevelop public land can reduce development fees for a private developer since the land can be sold at far-below-market-rate.

The excess parking in the public garage could also provide additional parking for the redeveloped site, further reducing construction costs.

Strategy 2D

Implement a shared parking and parking benefit district policy that will enable better utilization of existing parking resources and enable infill development

Lead Implementer:	City of Little Rock Planning and Development
Other Groups:	LRCVB; Private Property Owners
Timeline:	Medium Term (4-8 Years)
Funding Sources:	No Funding Required

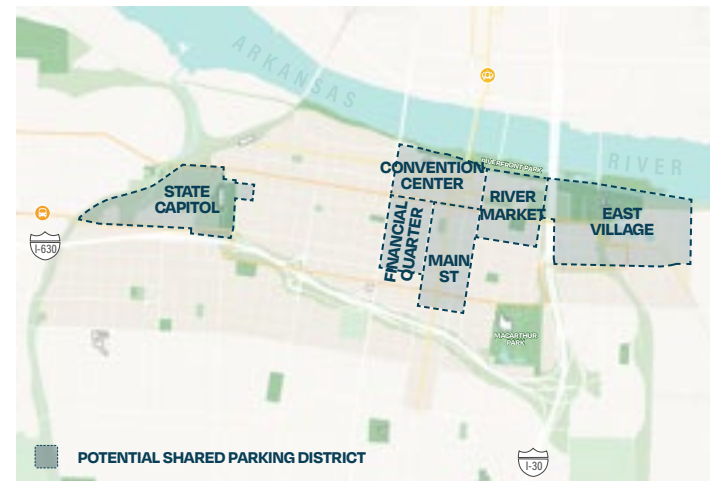

Presently, parking in Downtown Little Rock operates on a property-by-property basis. Although minimum parking requirements were removed from UU zoning, the vast majority of property owners are providing their own parking through surface lots or in garages with little in the way of parking agreements exist across tenants and properties. This is an inefficient use of existing resources and has resulted in the sea of parking lots seen today. Creating policy mechanisms that reimagine parking as a shared resource is essential to changing development patterns downtown. By changing City code and creating clear and easy methods by which nearby property owners can utilize each others parking assets during different days or times of day, existing lots will see more daily use, while others will be freed up for infill development.

A parking benefits district is another tool that the City should adopt as a policy. A parking benefit district typically operates through a system of parking meters, parking permits, or other parking access-controlled areas which administer parking fines for non-compliance. The revenue generated from these sources is collected and managed by a local authority or organization designed to oversee the parking assets in the district. The funds collected from parking fees and fines are then reinvested back into the district after parking asset operating and capital costs have been settled. The primary goal is to use the revenue to improve parking and transportation options within the district. In the case of Downtown Little Rock, a primary goal would most likely focus on consolidating parking inventory for shared public use.

A potential parking benefits district near the Statehouse Convention Center could use public and private garages, treated as a shared resource, to generate parking revenue to fund public realm upgrades in the district. If a new public garage is constructed to support the Convention Center, the new garage, combined with other garages, could also help provide supportive parking for surrounding properties, enabling their redevelopment more easily by removing parking from the development equation and by allowing existing surface parking lots to parking in garages.

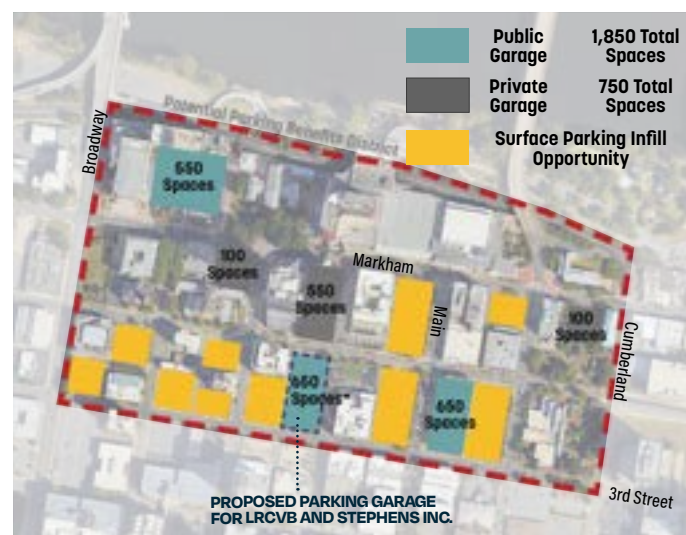

Strategy 3A

Incentivize the construction of a new grocery store and/or chain retailer supermarket/pharmacy within the core of Downtown

Lead Implementer:	City of Little Rock
Other Groups:	Little Rock Regional Chamber
Timeline:	Medium Term (4-8 Years)
Funding Sources:	TIF Funding (once TIF is established); New Markets Tax Credits

Having a grocery store and other daily needs retail Downtown Little Rock was cited as one of the highest priorities of the public and one of the main impediments to increasing the residential population in the area. But due to the relatively low residential population, a new grocer is unlikely to enter the market until the population increases. With increasing residential population as a key goal of this plan, the City and Downtown Partnership should actively pursue residential densification, enhancements at existing nearby grocers and retailers, and improved transit connections to those assets before looking to recruit a new grocer tenant.

The City should explore leveraging their existing public land or partner with other public agencies to leverage other public land as a potential site for a new grocery. One ideal location is the State-owned land located at 9th and Main Street, which could locate a new mixed-use development and grocer in the heart of Downtown and along a proposed new BRT corridor.



Urban format grocers or pharmacies should be colocated as a part of mixed-use development, with front doors on the street and with either structured parking or parking located at the rear of the building to encourage pedestrian access.

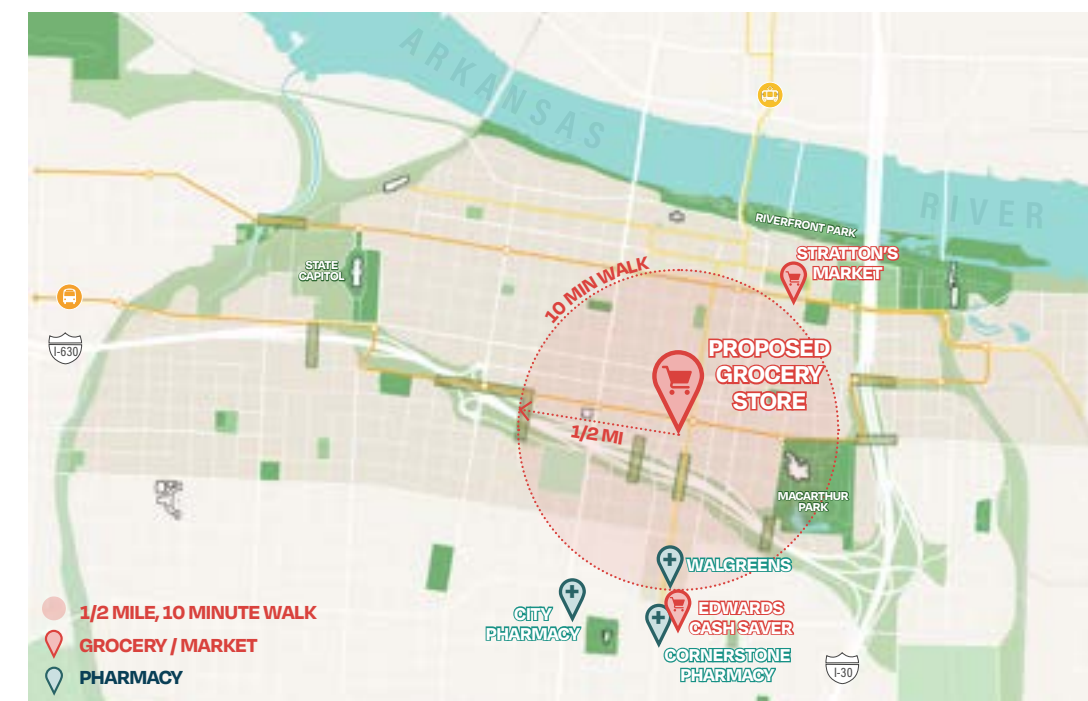

Action Steps

- 1 Encourage use of and improvements to existing facilities, including Walgreen's, Edwards, City Pharmacy, and Stratton's Market.
- 2 City should incentivize the construction of a new urban grocer and/or large-format pharmacy in the urban core through tax subsidies or the below-market long-term lease of city-owned land.

Strategy 3B

Identify neighborhood hearts to investment in streetscape and infrastructure enhancements that build off existing assets like popular businesses and historic buildings in order to drive reinvestment

Lead Implementer:	City of Little Rock Public Works; City of Little Rock Planning and Development
Other Groups:	Private Property Owners
Timeline:	Short, Medium, and Long-Term (see map below)
Funding Sources:	Safe Routes to School grants; STBG Grants; City General fund; Future City Bond



Neighborhood hearts are the commercial center for the neighborhood fabric around them. With retail for daily life such as dry cleaners, coffee shops, and daycares, these areas create the sense of place, make walking the preferred option, and improve quality of life.

Critical to creating these hearts is high-quality infrastructure. This includes wide sidewalks with room for restaurant patios, public open spaces for community gathering, and high-frequency transit stops.

Surrounding and integrated into these hearts are a variety of residential options, including multifamily, townhomes, duplexes, and single-family homes. This housing provides the customer base for the neighborhood hearts.

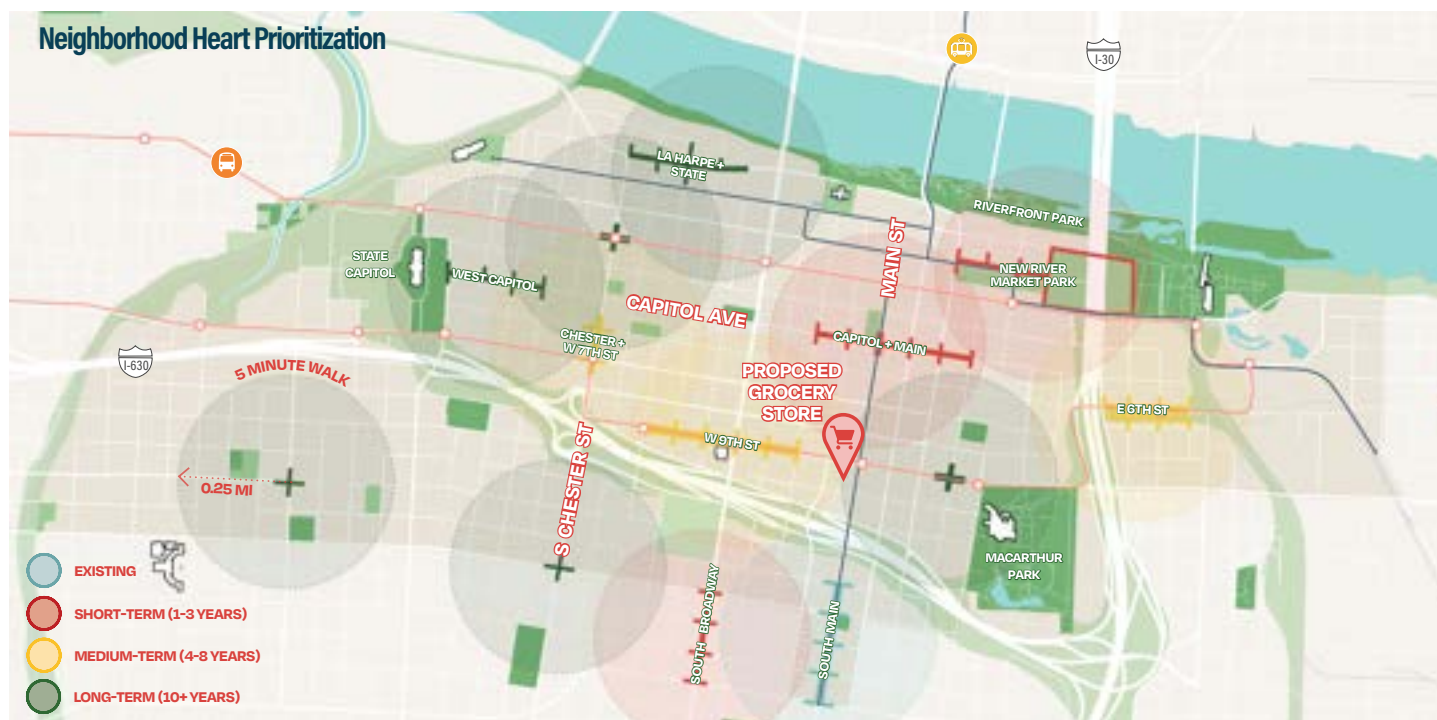

Strategy 3C

Establish a Downtown Revitalization Fund that provides financial incentives for businesses to relocate to Downtown

Lead Implementer:	City of Little Rock
Other Groups:	Little Rock Regional Chamber; Downtown Partnership
Timeline:	Short Term (1-3 Years)
Funding Sources:	City General Fund

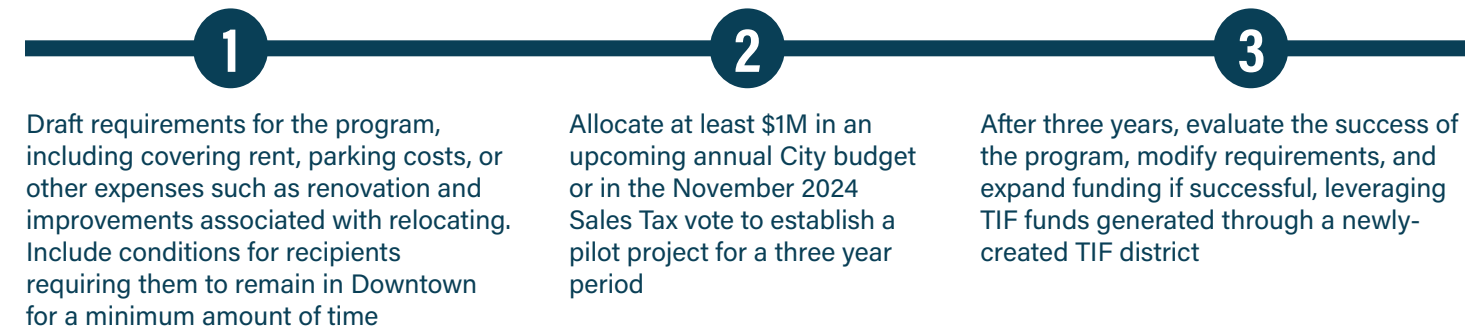

Strategy 4A

Amend UU zoning to change permitted height and use requirements and prohibit uses such as drive-thrus, gas stations, and surface parking lots

Lead Implementer:	City of Little Rock Planning and Development
Other Groups:	Downtown Density Taskforce
Timeline:	Short Term (1-3 Years)
Funding Sources:	No Funding Required

UU Zoning

UU (Urban Use) zoning is the primary zoning district for Downtown. Although past amendments have made notable improvements, including removing parking requirements, there still exist numerous barriers to development within the code. Changes to the code should include:

- Prohibit currently-permitted uses including drive-thrus and gas stations due to the detrimental impacts they have on walkability.
- Require parking lot design/landscaping standards, including a maximum parking lot size that is 25% of overall parcel size and enhanced tree planting.
- Change height requirements to permit up to 85' by right to enable Type III-A construction. Additionally, remove requirements for vertically-integrated mixed-use, repacing requirements with enhanced streetscape design and tower setback requirements.

Strategy 4B Reduce regulatory barriers for new residential development Downtown

Lead Implementer:	City of Little Rock Planning and Development
Other Groups:	None
Timeline:	Short Term (1-3 Years)
Funding Sources:	No Funding Required

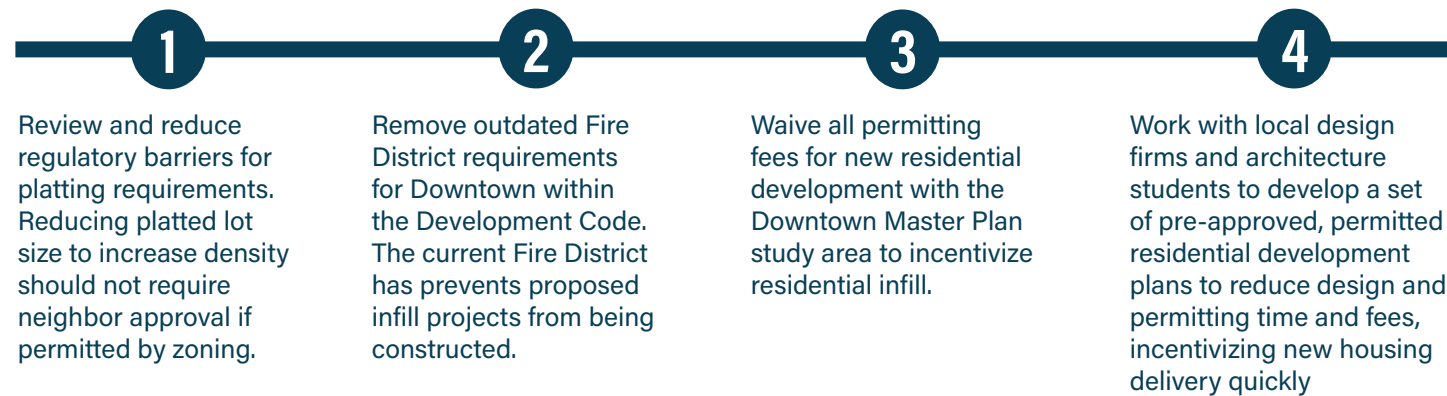

Strategy 4C Reevaluate Capitol Zoning District requirements to make redevelopment more viable in those areas of Downtown

Lead Implementer:	Capitol Zoning Commission; State of Arkansas
Other Groups:	City of Little Rock Planning and Development
Timeline:	Short Term (1-3 Years)
Funding Sources:	No Funding Required

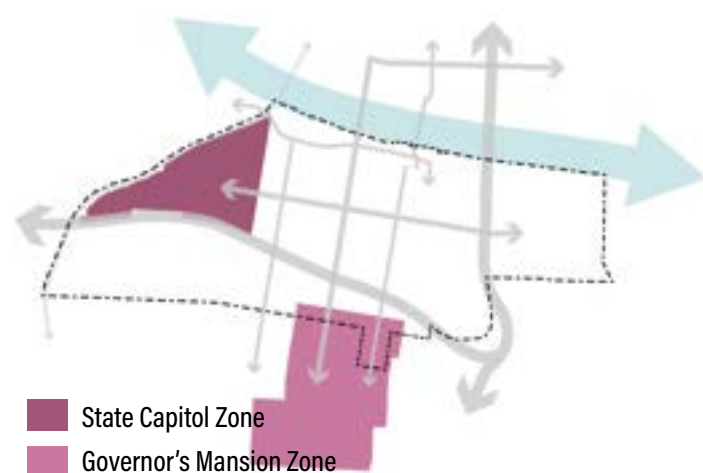

The State-managed zoning district, Capitol Zoning District, comprises a large portion of the southern and western areas of Downtown Little Rock. The Zoning District currently has a master planning process underway with the intention of updating the zoning.

Through the Downtown Little Rock Master Planning process, key barriers were identified that the Zoning District's master plan should address. These include:

- Eliminate barriers for multifamily development such as number of family requirements per parcel
- Reduce parking requirement to align with UU Zoning
- Reduce required property-line setbacks
- Permit lower lot area per dwelling unit requirements
- Increase permissible building heights

Strategy 4D Develop a residential development toolkit, public-private partnership and incentives toolkit, and a residential pattern book to encourage new residential construction.

Lead Implementer:	City of Little Rock; Downtown Partnership, New Development Corporation
Other Groups:	Private Development
Timeline:	Short Term (1-3 Years)
Funding Sources:	City General Fund; HUD Choice Neighborhoods Planning Grant; HUD Sustainable Communities Regional Planning (SCRIP) Grant

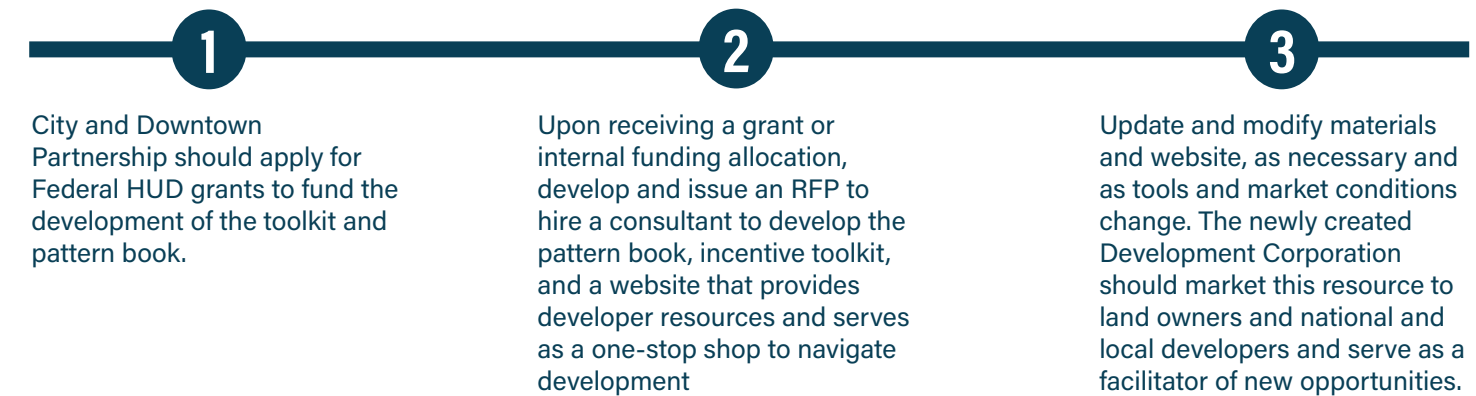

The creation of a residential toolkit could unlock potential development opportunities that land owners and developers did not know existed. Given the limited activity from national developers, small scale developers and land owners simply do not know of the opportunities that exist. The goal of this strategy is to systematic infill underdeveloped parcels within downtown with a diversity of housing options that serve all types of demographics, from families to affordable and workforce needs to market rate options. The toolkit should be designed to facilitate information and streamline processes. By developing pre-approved typologies, this tool can cut down on time needed to bring a project to market, which is one of the largest barriers for smaller developments. This development toolkit should be fundamentally created



to deliver more housing. By focusing on cost effective commodity products, the delivery of more housing will shift the market to a place where it can hopefully function on its own without incentives. However, that will take time and utilizing a strategy like this can give a roadmap for reaching the goal of doubling the downtown population quickly. The newly formed Development Corporation should actively use this tool to try and make new projects of all sizes happen, and the City should use this as a resource to streamline approval processes. At the same time, it is imperative for the City of Little Rock to work to protect existing homeowners and residents from displacement caused by rising property values. Additional policy should be explored to protect historic minority communities south of I-630.

Residential Typology Pattern Book

Prevailing Development Sites

Although no two parcels are exactly the same, due to the regular grid pattern in Downtown Little Rock, there are predominant development site typologies. The five development sites shown here should serve as a starting point for considering the diverse array of residential building typologies that are possible

Infill Parcel Between Buildings

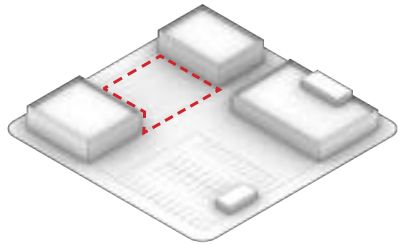

+/- 0.35 Ac | +/- 15,000 SF

Quarter Block (140' x 140')

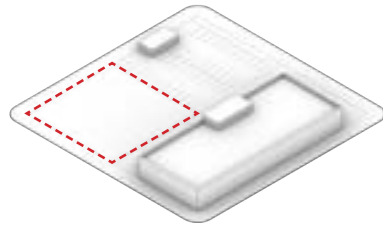

+/- 0.45 Ac | +/- 20,000 SF

Half Block (140' x 300')

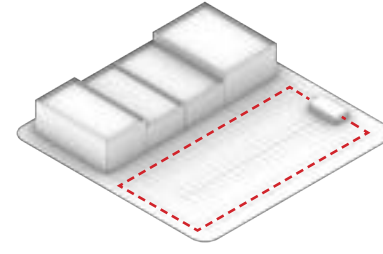

+/- 0.9 Ac | +/- 40,000 SF

Full Block (300' x 300')

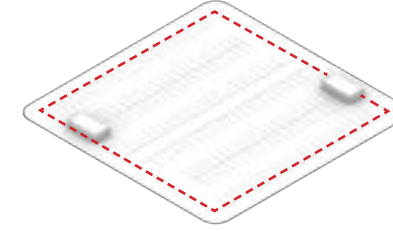

+/- 1.8 Ac | +/- 80,000 SF

Irregular, Large Block (>300')

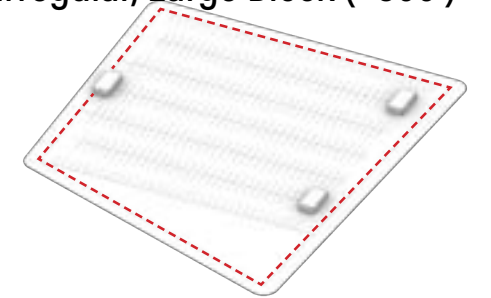

+/- 2.5 Ac | +/- 100,000 SF

Residential Typologies

Each development site has different feasible typologies based on its dimensions and its location in Downtown. The projected number of units and parking spaces are estimates to help inform potential development decisions by future developers.

A key aspect of increasing residential development is limiting the cost barriers to construction. This includes everything from construction type, parking requirements, ground floor uses, etc. A few considerations for the development of this pattern book is how to increase small scale residential fabric and how to attract institutional developers.

For small scale developments this strategy should look at elements such as allowing point-access blocks (buildings with one stair/elevator core), utilizing on-street parking, and allowing residential ground floors on most streets. Assisting in land assembly and providing pre-approved site plan typologies to limit delivery time will help attract larger institutional capital.

Each physical typology should be accompanied with a series of economic incentives.

Townhomes

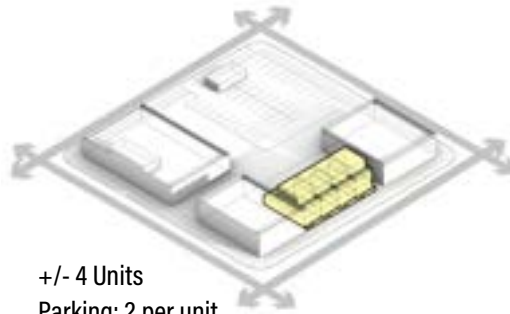

+/- 4 Units
Parking: 2 per unit

Quadplex

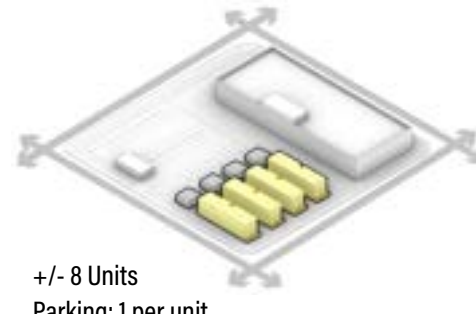

+/- 8 Units
Parking: 1 per unit

Townhomes

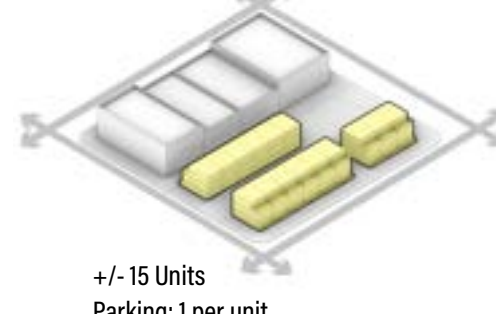

+/- 15 Units
Parking: 1 per unit

Townhomes

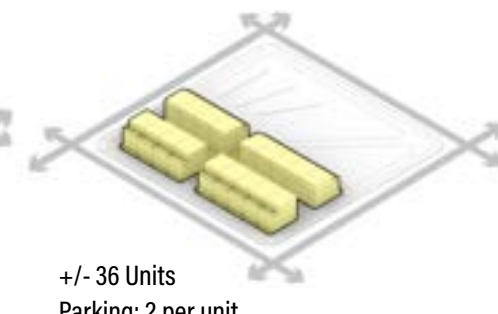

+/- 36 Units
Parking: 2 per unit

Texas "Donut"

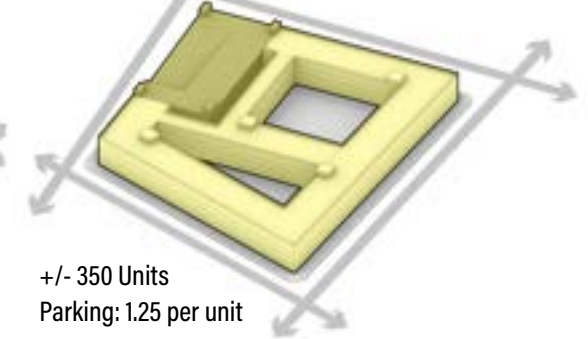

+/- 350 Units
Parking: 1.25 per unit

Walk-up Flats

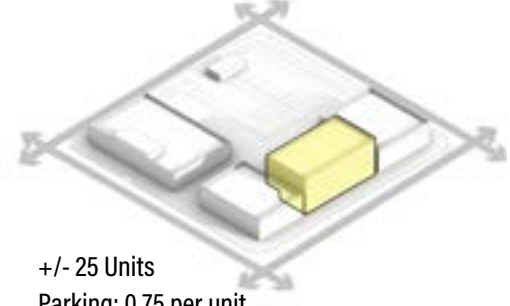

+/- 25 Units
Parking: 0.75 per unit

Townhomes

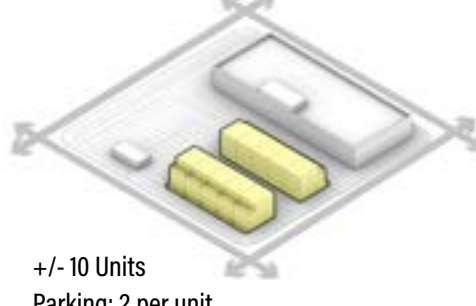

+/- 10 Units
Parking: 2 per unit

4-Over-1 Multifamily

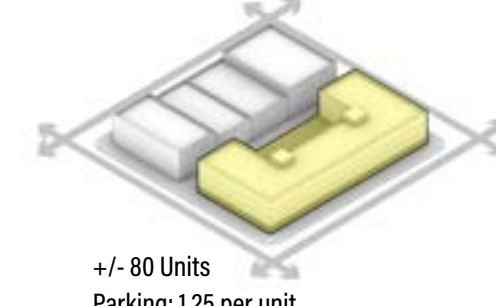

+/- 80 Units
Parking: 1.25 per unit

Texas "Donut"

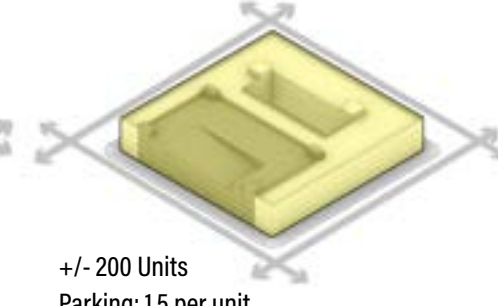

+/- 200 Units
Parking: 1.5 per unit

Residential Tower

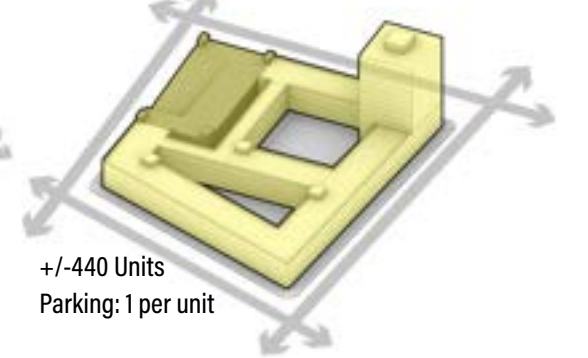

+/- 440 Units
Parking: 1 per unit

Walk-up Flats

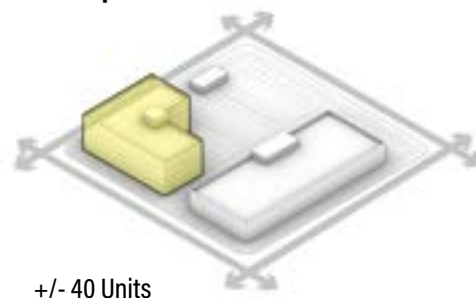

+/- 40 Units
Parking: 0.5 per unit

5-Over-2 Multifamily

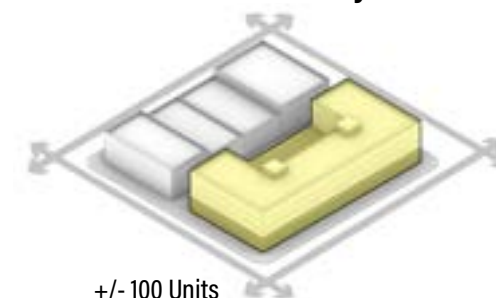

+/- 100 Units
Parking: 1.25 per unit

5-Over-2 Multifamily

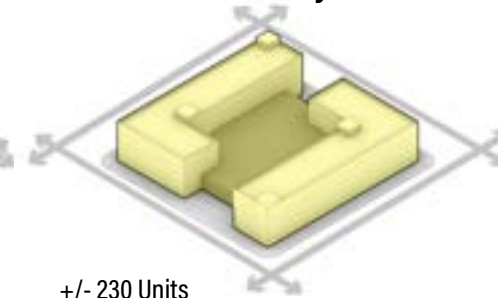

+/- 230 Units
Parking: 1 per unit

Strategy 1A

Expand the existing METRO Streetcar system to better connect key downtown neighborhoods and connect residents to neighborhood-serving amenities

Lead Implementer:	Rock Region Metro
Other Groups:	City of Little Rock, Metroplan, Pulaski County
Timeline:	Rubber tire bus: Short Term (1-3 Years) Streetcar expansion: Long Term (10+ Years)
Funding Sources:	USDOT BUILD Grant; USDOT RAISE Grant



1

2

3

Create a dedicated rubber-tire shuttle between SOMA and the River Market with 15-minute frequency and well-branded stops. This could be bus, or an alternative transit technology.

Extend the METRO Streetcar down Main Street to connect Downtown to SOMA and Pettaway

Long-term, a future east-west alignment down Markham Street to Union Station and east to Bond Street, with expansion considerations to Little Rock National Airport could be explored.

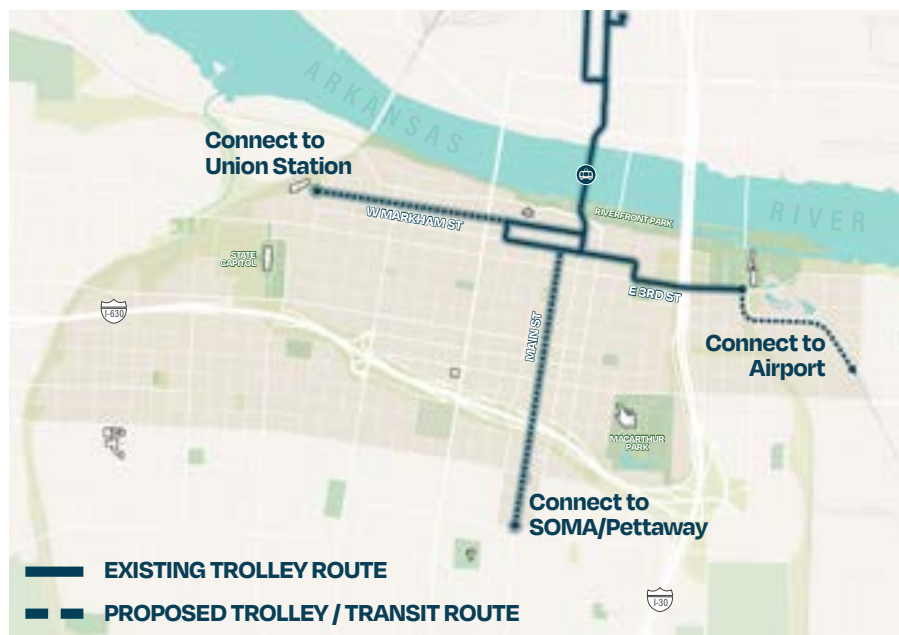

Testing potential routes through shuttles and dedicated bus routes are a cost-effective way to identify preferred mobility patterns and ensure long-term operational success. This first step should explore USDOT Mobility and Technologies grants to test a shuttle pilot program.

Long-term expansion of the network should hinge on the success of the shuttle program. If utilization is high, a dedicated streetcar extension should be explored to SOMA and Pettaway. Future expansion of the network should also include replacing some or all of the heritage trolleys with modern streetcars, which are faster and meet modern accessibility requirements, allowing the streetcar to function as a true transit system.

Strategy 1B

Operate a dedicated transit route connecting destinations such as UAMS, the Capitol, Children's Hospital, Philander Smith, the River Market, and East Village.

Lead Implementer:	Rock Region Metro
Other Groups:	City of Little Rock, Metroplan, Pulaski County; UAMS, Ark. Children's Hospital
Timeline:	Pilot project shuttle: Short Term (1-3 Years) Dedicated BRT system: Long Term (10+ Years)
Funding Sources:	FTA New Starts/Small Starts Grants; FTA TOD grants; USDOT BUILD Grant; USDOT RAISE Grant; Innovative Coordinated Access and Mobility Grants



1

2

3

Coordinate Rock Region Metro, Children's Hospital, and UAMS to pursue EPA Grants to fund a pilot project shuttle between the hospitals and other key sites

In addition to the hospital pilot program, Rock Region should enhance existing service frequency on the 8-Route, including bus stop upgrades.

Should the pilot program and transit enhancements be successful, Rock Region should pursue federal grants to create a high-frequency bus route

Although Downtown Little Rock is the epicenter of Rock Region Metro's transit network, transit ridership in Little Rock is very low due to low frequency, poor reliability, and the lack of direct connections between key job centers and residential areas.

A potential Bus Rapid Transit (BRT) loop connecting East Village, Downtown, Philander Smith University, Arkansas Children's Hospital, the State Capitol, UAMS, and the VA Medical Center could connect over one-quarter of all jobs in Pulaski County to each other, while also connecting to existing residential neighborhoods. Strategic planning for infill around potential transit stops could drive additional transit-oriented development along the route.





Strategy 1C

Enhance existing transit infrastructure, including installing new bus shelters along key routes and new bus-tracking technology to encourage convenient and comfortable ridership experience

Lead Implementer:	Rock Region Metro
Other Groups:	City of Little Rock, Metroplan, Pulaski County
Timeline:	Medium Term (4-8 Years)
Funding Sources:	FTA All Stations Accessibility Program Grants



Throughout the planning process, the public expressed the desire to take transit but currently find the system to be unpredictable and unsafe. Strategic improvements on key corridors in Downtown such as more prominent bus shelters with lighting, real-time bus track technology, and enhanced wayfinding will improve the visibility and predictability of transit and help navigators better understand route destinations. This should help drive additional transit ridership, reducing the need for parking Downtown. Rock Region Metro should pursue FTA All Stations Accessibility Grants to implement many of the suggested transit enhancements.



Source: Metro Little Rock Guide



Strategy 2A

Close State Street and Center Street bridges to vehicular traffic, making tactical improvements to those bridges including lighting, paint, and landscaping

Lead Implementer:	City of Little Rock Public Works
Other Groups:	ARDOT; Metroplan; StudioMAIN
Timeline:	Medium Term (4-8 Years)
Funding Sources:	USDOT RAISE Grant; USDOT SMART Grant; Arkansas Intersection Improvement Program grants; Private Philanthropy

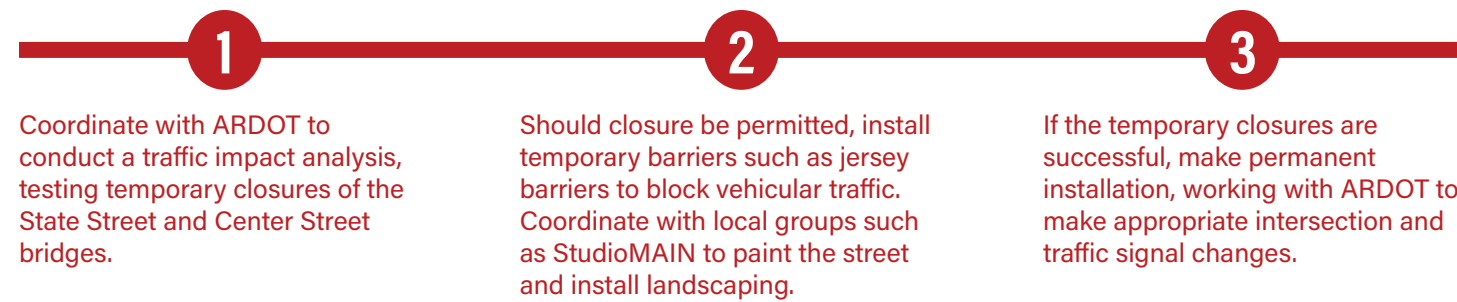

Today, most Downtown bridges are largely dedicated to vehicular travel.

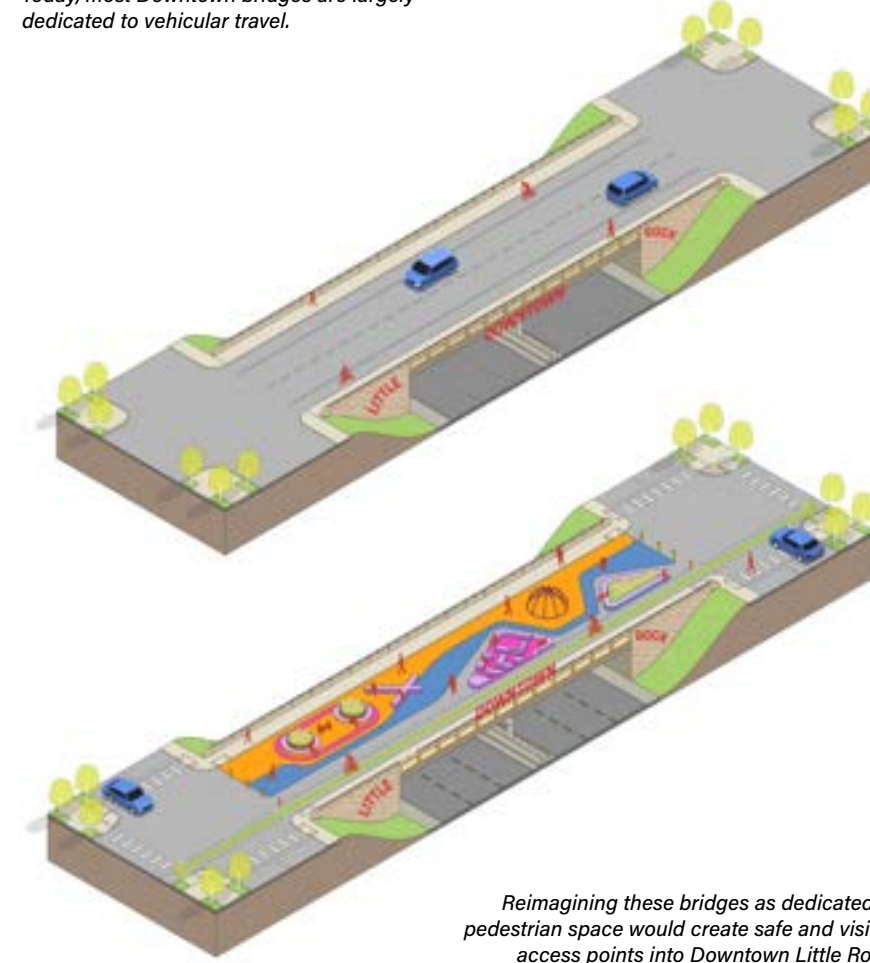

Reimagining these bridges as dedicated to pedestrian space would create safe and visible access points into Downtown Little Rock.

Although I-630 is a substantial barrier separating Downtown from surrounding neighborhoods, there are numerous bridges connecting both sides. Today, these bridges are highly utilitarian, with little in the way of bike or pedestrian amenities. These bridges could be reimagined in alternatives ways to enhance connectivity between divided districts.

Two streets are currently underutilized for vehicular traffic while also connecting key assets. Center Street has the potential to be a ceremonial multimodal and green corridor connecting the Old State House to the Arkansas Governor's Mansion, while State Street can connect the Dunbar neighborhood and Philander Smith University to the Arkansas River as a part of a cultural loop.

Reimagining these two assets as pedestrianized and completely closed to traffic would create strong and safe pedestrian and bike crossing locations while also helping to create functional plazas in areas with little public open space. Improvements could include potted landscaping, shade structures, street furniture, and public art.

Strategy 2B

Make strategic improvements to the Main Street, Commerce Street, Marshall Street, and Third Street bridges to include widened sidewalks and bike lanes

Lead Implementer:	City of Little Rock Public Works
Other Groups:	City of Little Rock, Metroplan, Pulaski County
Timeline:	Medium Term (4-8 Years)
Funding Sources:	USDOT RAISE Grant; USDOT SMART Grant; Arkansas Intersection Improvement Program grants; City Bond; City General Fund

1

Coordinate with ARDOT to conduct a traffic impact analysis, understanding potential traffic implication from lane reductions

2

Conduct pilot projects on priority bridges for public realm expansion, using tactical urbanism techniques.

3

Should pilots be successful, install permanent enhancements through City funding and grants.

Although a few bridges are optimal to explore for complete closure to vehicles, others are critical for the district's circulation. These key bridges, particularly Main Street, Commerce Street, Marshall Street, and Third Street, should be studied for bike and pedestrian enhancements to enhance connections between surrounding neighborhoods and the core of Downtown. At a minimum, enhancements should include physically separated bike lanes and enhanced pedestrian infrastructure on either end, including new crosswalks and enhanced ADA accessibility. On key corridors such as Main Street, sidewalks should be widened to create more space for pedestrians.

Enhancements to key bridges should include wider sidewalks and pedestrian elements such as potted plantings and physical barriers at the bridge edge to attenuate sound.

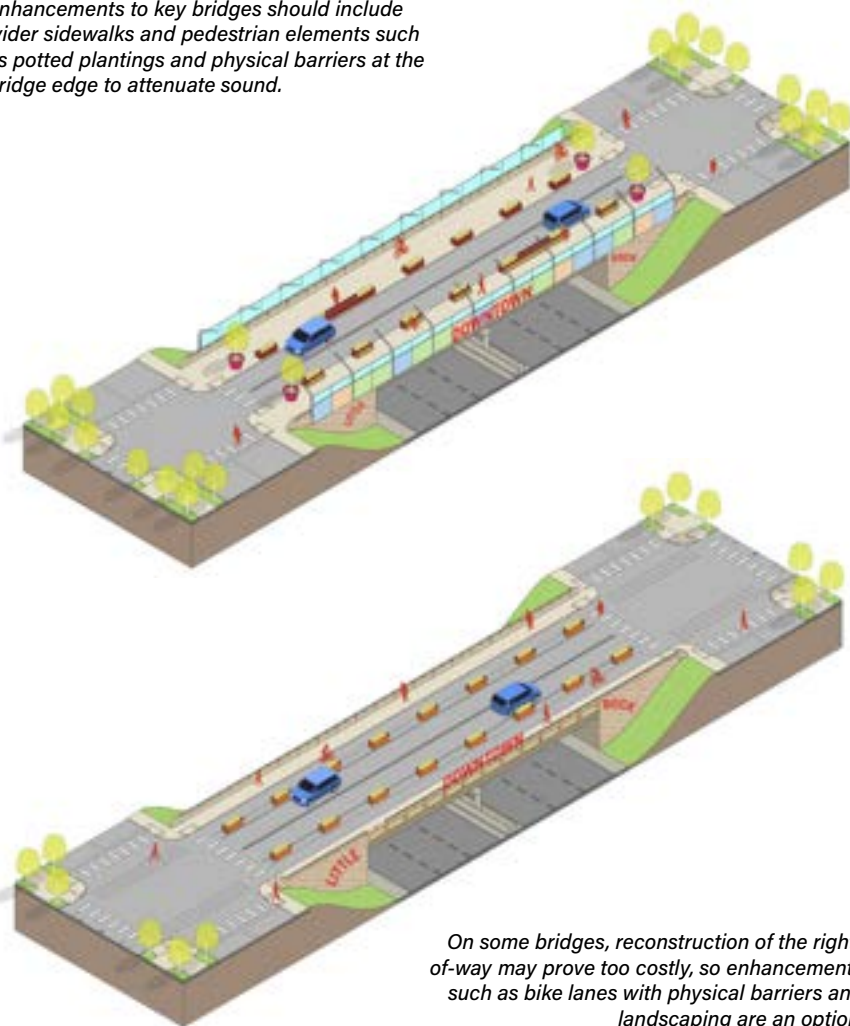

On some bridges, reconstruction of the right-of-way may prove too costly, so enhancements such as bike lanes with physical barriers and landscaping are an option.

Strategy 2C

Leverage the Reconnecting Communities Deck Park study to explore enhanced bridge crossings or deck parks at the 6th and 9th Street bridges over I-30

Lead Implementer:	City of Little Rock
Other Groups:	ARDOT; Metroplan
Timeline:	Long Term (10+ Years)
Funding Sources:	USDOT Reconnecting Communities and Neighborhoods Grant

Fifth Street | Atlanta, GA



Source: Georgia Tech

Prior to the Downtown Master Plan, the City of Little Rock was awarded a \$2 Million grant from the USDOT Reconnecting Communities program to explore the possibility of constructing a deck park between 6th Street and 9th Street over Interstate 30. Throughout the planning process, the public and advisory committees cited a new deck park as a lower priority than other enhancements due to its costs.

Due to engineering challenges and potential costs and maintenance issues, alternatives to a full deck park (such as Klyde Warren Park in Dallas) should be explored. These include substantially enhanced and widened bridges at 6th and 9th Street (such as was done on 5th Street in Midtown Atlanta) or constructing buildings over the interstate as was done on High Street in Columbus, Ohio.

High Street | Columbus, OH



Klyde Warren Park | Dallas, TX

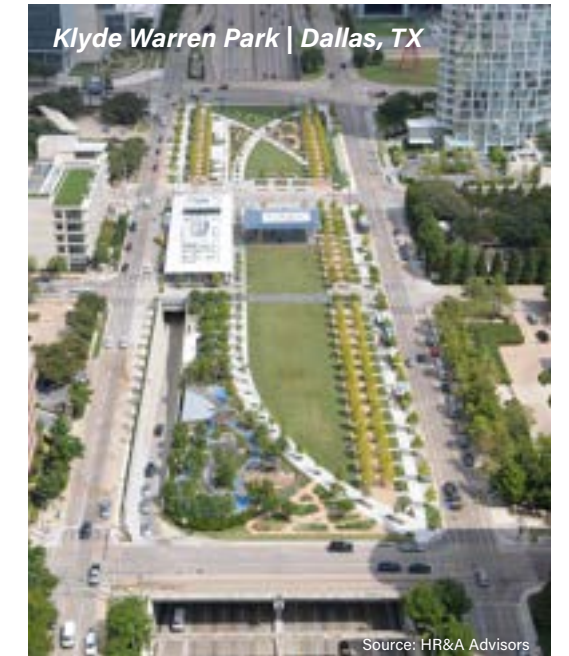

Source: HR&A Advisors

Strategy 2D

Collaborate with ARDOT on any future reconstruction plans for I-630 to ensure all existing connection points, establish a new connection point on West Ninth Street, consolidate access ramps to fewer, centralized locations, and to construct a small deck park at Chester and West Ninth.

Lead Implementer:	City of Little Rock
Other Groups:	ARDOT; Metroplan
Timeline:	Long Term (10+ Years)

1

2

3

Using the Master Plan as a starting point, coordinate with local stakeholders and designers to develop a conceptual vision for the I-630 corridor.

City of Little Rock Board of Directors should adopt a resolution requiring future interstate construction to preserve existing connections, provide new connections, build ramps no higher, and build highway right-of-ways no wider.

Upon initiation of a future reconstruction project of I-630 by ARDOT, City should coordinate city staff and local designers and collaborate on design throughout the design-development process.

The construction of Interstate 630 damaged historic neighborhoods fabric, destroyed historic buildings, and caused emotional and physical trauma on those areas and their surrounding neighborhood fabric. While the damage done cannot be repaired through physical improvements, future reconstruction of Interstate 630 should do all that it can to heal the wound.

To prevent future highway projects from causing undo harm on adjacent neighborhoods, the City of Little Rock should adopt policy guidance and design requirements for ARDOT to adhere to, ensuring existing connections are preserved, new connections are created, and no additional right-of-way is acquired.



When I-630 is slated for reconstruction, the City of Little Rock should establish a collaborative working design committee with ARDOT to ensure appropriate design measured are followed. This should include creating a new connection at West Ninth Street, including a small deck park opportunity at Chester Street, consolidation of the off-ramps between Broadway and Cumberland Streets, the narrowing of highway footprint to the greatest extent possible within existing right-of-way, and the greening of unused portions of the right-of-way to improve the appearance and reduce urban heat island impacts. Additionally, existing bridges should be reimagined as multimodal connections, with ample space for bike and pedestrians on all bridges.

Conceptual Vision for I-630

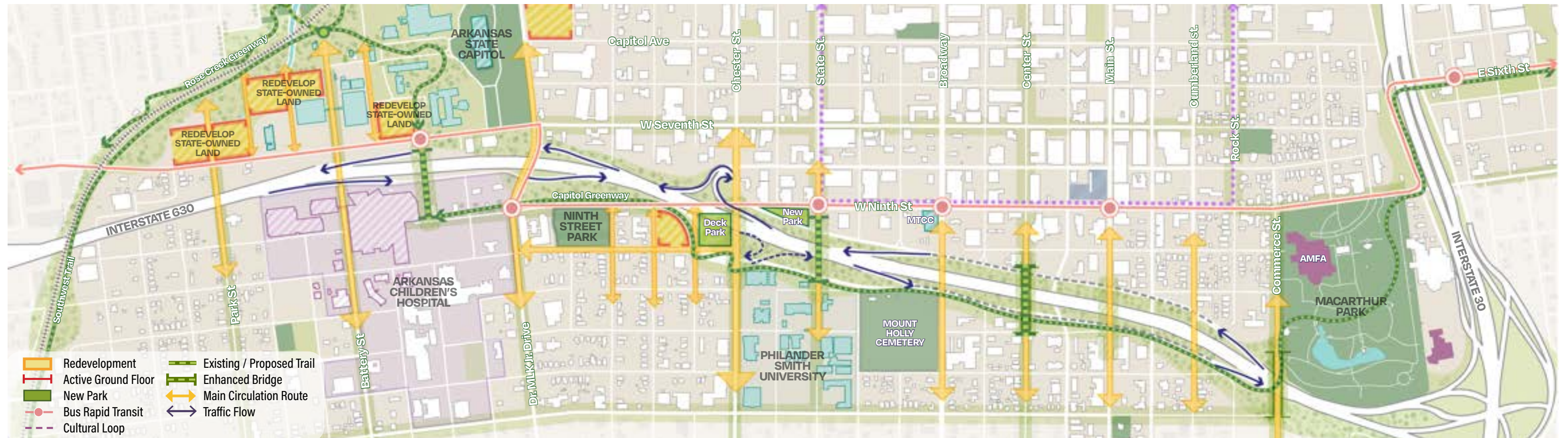

Strategy 3A

Prioritize reducing the number of travel lanes on Capitol Avenue, reconstructing the entire right-of-way

Lead Implementer:	City of Little Rock Public Works
Other Groups:	Metroplan
Timeline:	Short Term (1-3 Years)
Funding Sources:	Metroplan STBG Grants; City Bond; City General Fund; Arkansas Intersection Improvement Program Grants; USDOT Safe Streets for All and SMART Grants

1

2

3

In coordination with the Boyle Building and Tech Park projects, pursue Metroplan STBG grant for reconstruction of Capitol from Scott Street to Center Street, or as funding permits.

Coordinate with local property-owners to identify a second portion for reconstruction, west of Broadway, using the same cross-section and street design elements as in Step 1. Pursue Metroplan grants.

Finish the remaining segments of the Capitol Avenue corridor through grants, bond projects, or private development, ensuring consistency in design across all segments.

Today, Capitol Avenue is a mixture of a two-lane, four-lane, and five-lane corridor, with a varied sidewalk widths, on-street parking, and irregular landscaping. Traffic volumes are as low as 2,000 per day, which presents an opportunity to implement a road diet down to two-lanes the entire stretch of the corridor. Capitol Avenue should be a pedestrian-friendly ceremonial street connecting the Capitol to the core of Downtown. Redesign should include a consistent street section, unified street furniture and landscaping, and uniform materials such as brick pavers to signify the importance of the roadway.

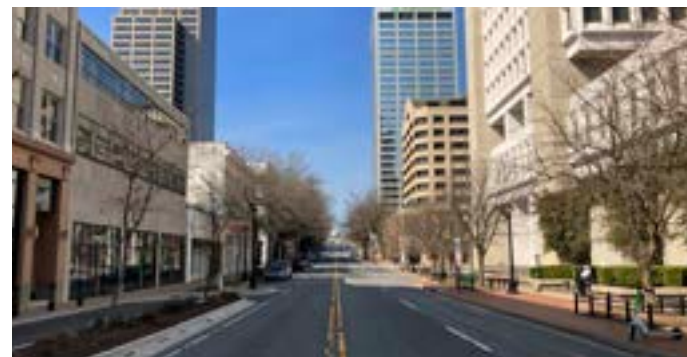

Existing

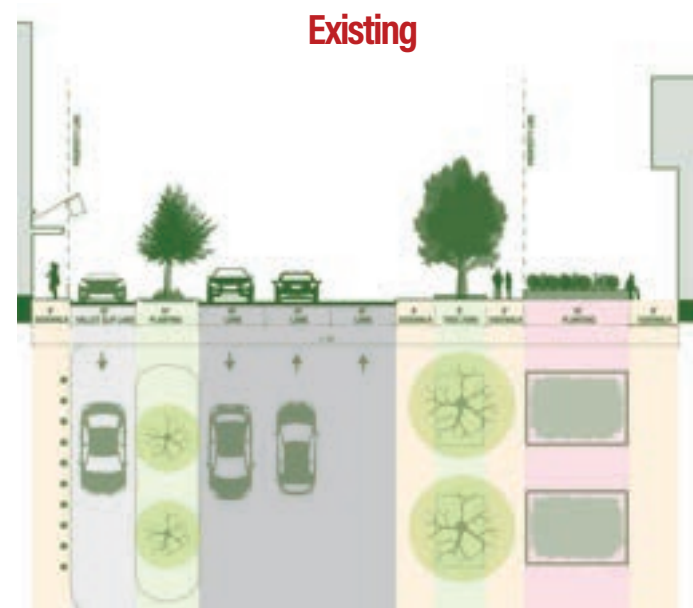

Proposed

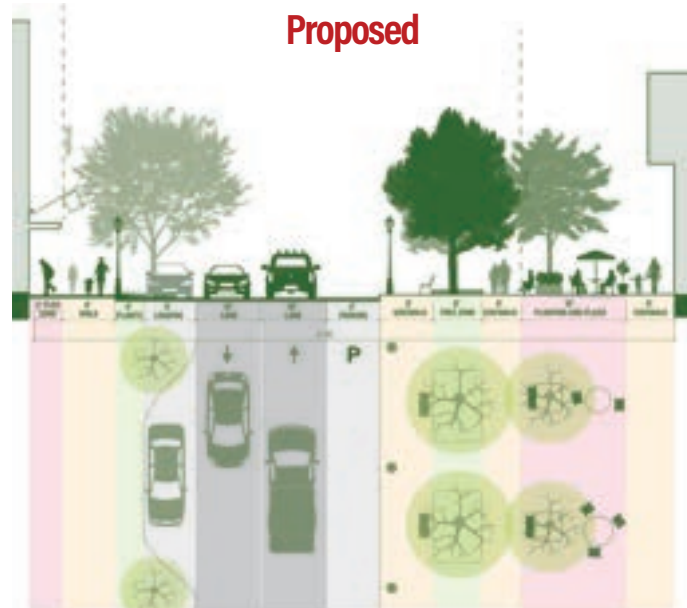

Conceptual Vision for Capitol Avenue

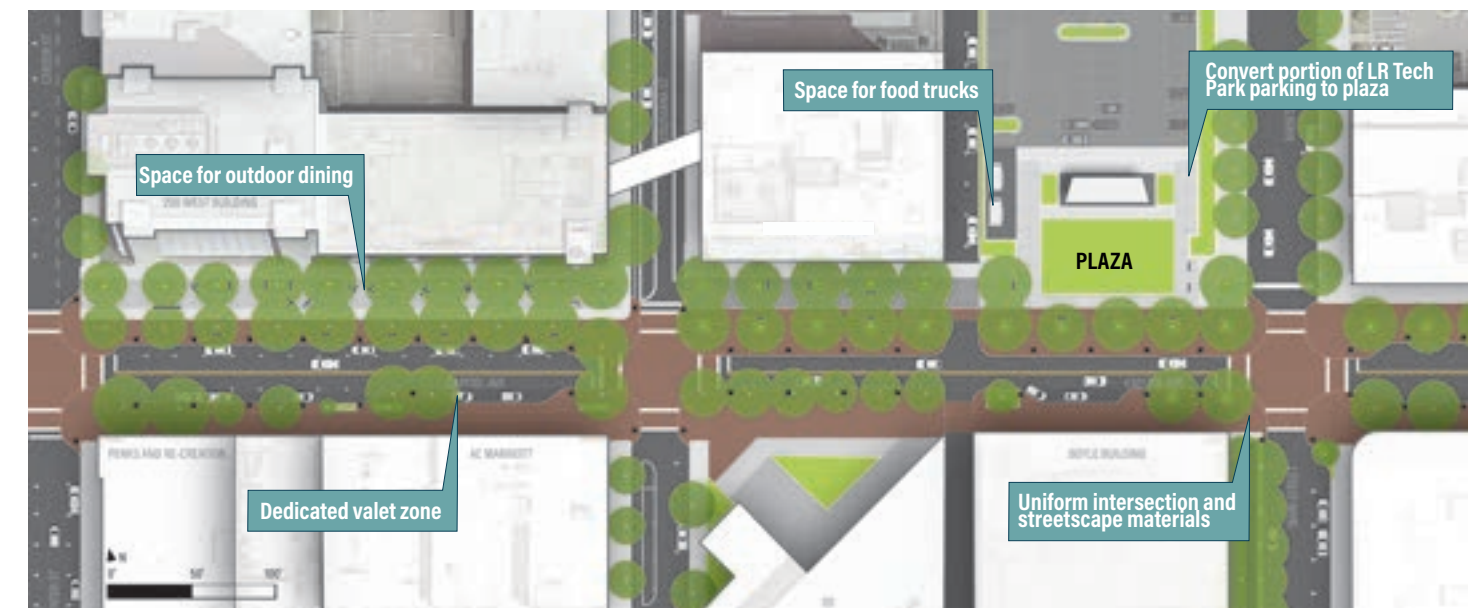
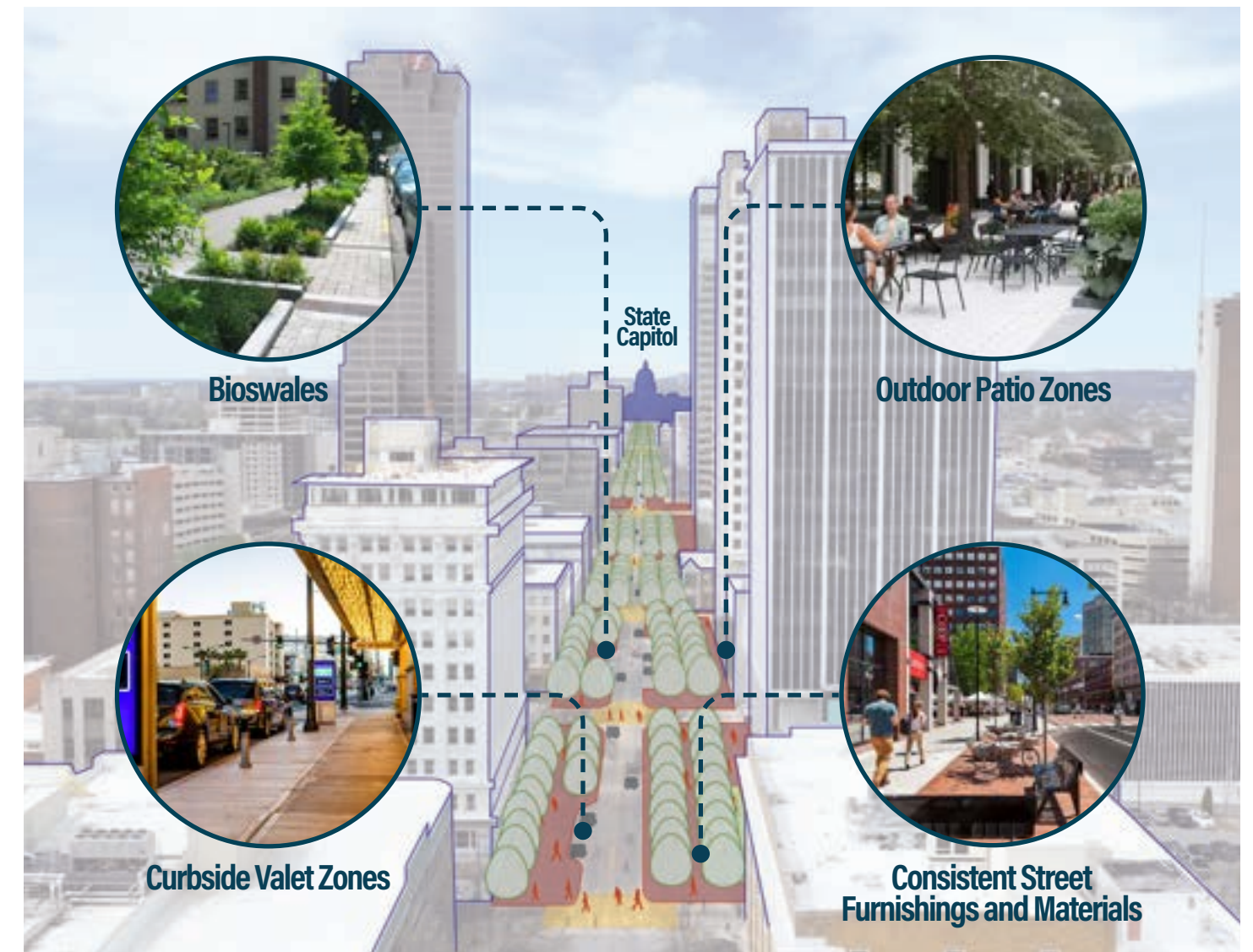



Strategy 3B

Prioritize converting one-way streets to two-way, including 2nd, 4th, 6th, 8th, and Center Streets

Lead Implementer:	City of Little Rock Public Works
Other Groups:	Metroplan; ARDOT
Timeline:	Prioritize 4th Street for Short Term (1-3 Years); Remainder are Medium Term
Funding Sources:	Metroplan STBG Grants; City Bond; City General Fund; Arkansas Intersection Improvement Program Grants; USDOT Safe Streets for All and SMART Grants

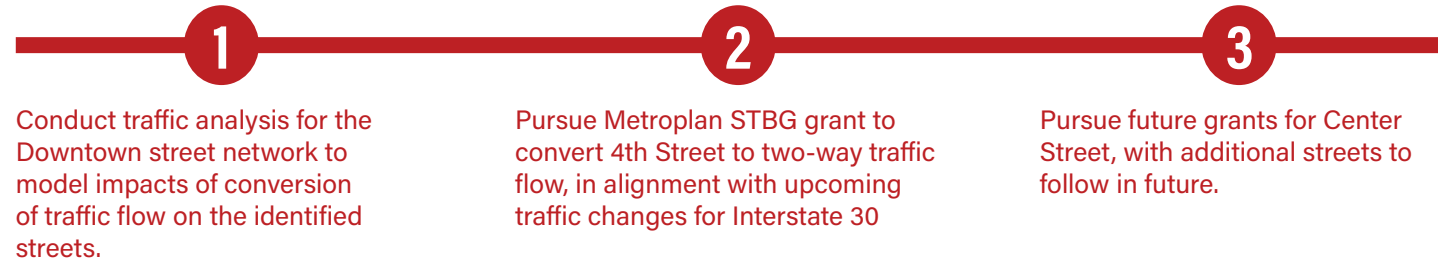

Strategy 3C

Explore replacing traffic signals with stop signs at underutilized intersections to reduce operations and maintenance costs, reallocating savings towards signal upgrades along two-way street conversions

Lead Implementer:	City of Little Rock Public Works
Other Groups:	None
Timeline:	Short Term (1-3 Years)
Funding Sources:	City General Fund

Numerous intersections in Downtown Little Rock have low traffic counts and yet are still regulated by traffic signals. These signals require operations and maintenance, a financial burden on the City, while also causing drivers to sit idle at empty intersections, increasing emissions and reducing regional air quality.

Using existing traffic counts to identify intersections where signals could be replaced by stop signs, long-term savings from reduced operations and maintenance can be spent on other traffic projects such as signal upgrades necessary for one-way to two-way street conversions.

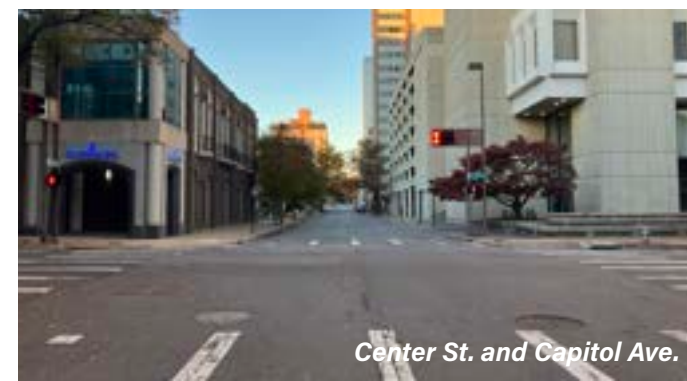

Strategy 4A

Prioritize Capitol Avenue, Center Street, Rock Street, State Street; and Commerce Street as key green corridors, including bike lanes, widened sidewalks, and enhanced landscaping

Lead Implementer:	City of Little Rock Public Works
Other Groups:	Metroplan
Timeline:	Rock or Cumberland St. in Short Term (1-3 Years); Remainder are Medium Term
Funding Sources:	Metroplan STBG Grants; City Bond; City General Fund; USDOT Safe Streets for All and SMART Grants

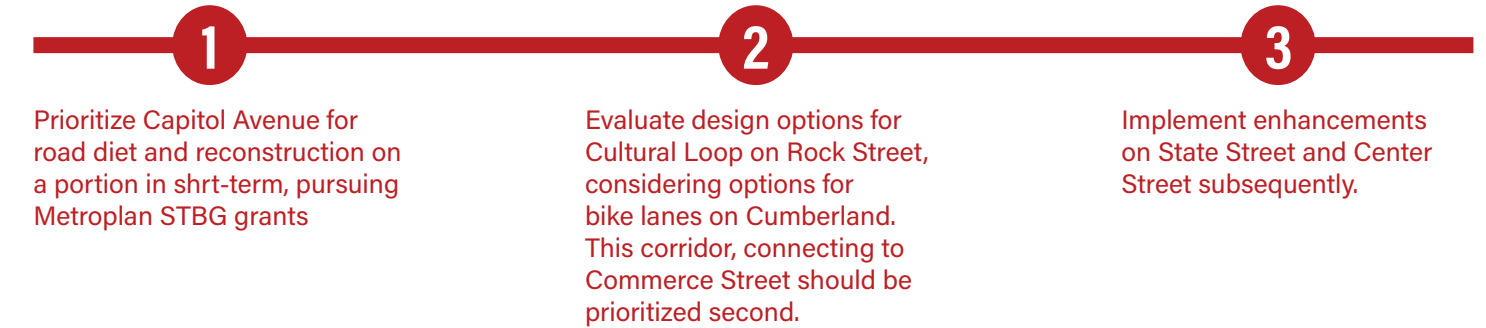

Strategy 4B

Adopt a roadway design policy that includes a streetscape kit of parts that includes recommendations for roadway cross-sections, landscaping, and street furniture.

Lead Implementer:	City of Little Rock Public Works
Other Groups:	None
Timeline:	Short Term (1-3 Years)
Funding Sources:	No Funding Required

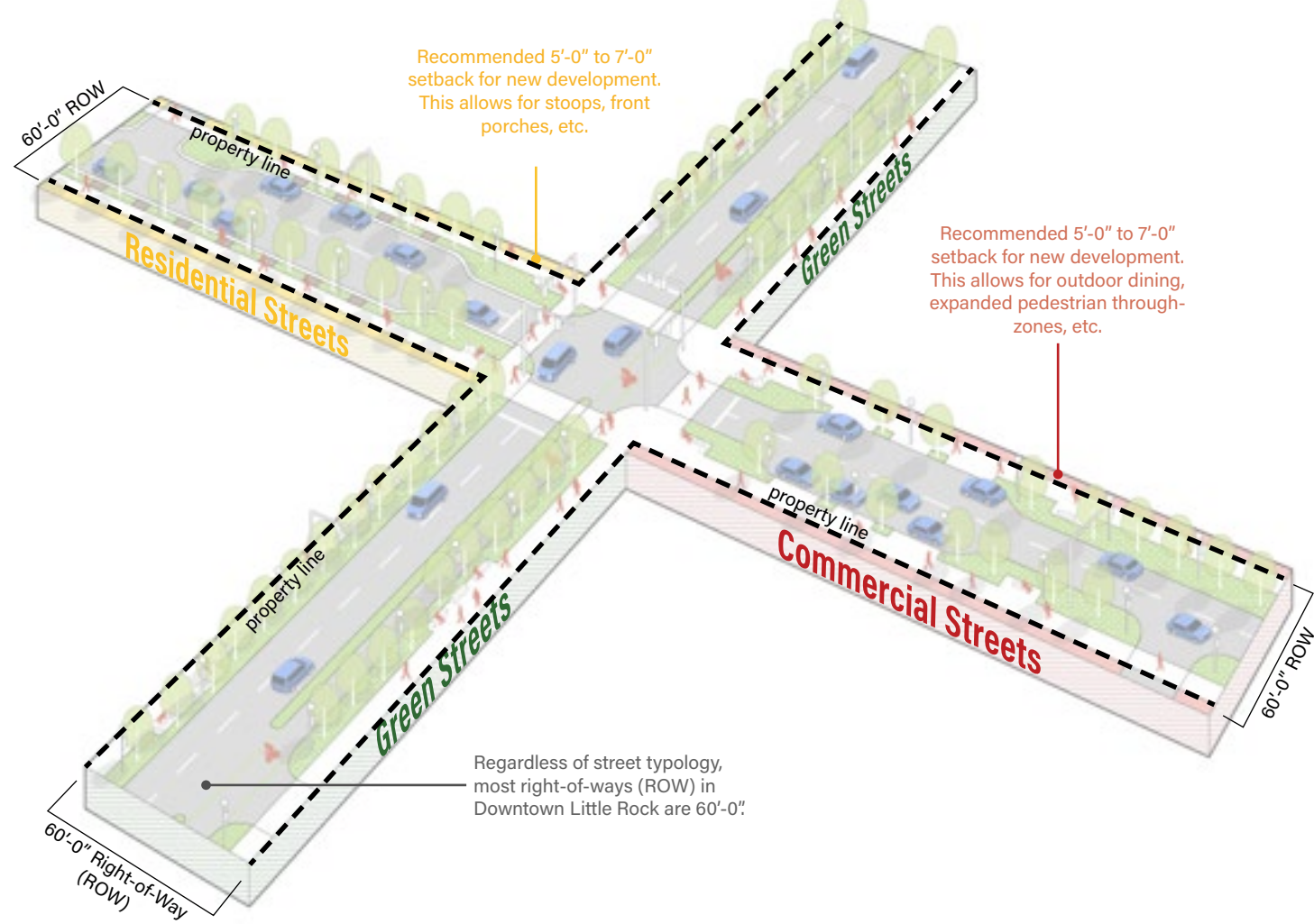

Applies to commercial streets

Applies to green streets

Applies to residential streets

Applies to all streets

Ownership

All land within the right-of-way (ROW; property line to property line) is the responsibility of either the City of Little Rock or Arkansas Department of Transportation (ARDOT) to operate, maintain, and improve. Land beyond the ROW (including setbacks, extended pedestrian zones, plazas, and so on) are the responsibility of the relative property owner. Exceptions exist for when property owners want to go above and beyond typical street improvements as specified in the roadway design policy. In these instances, maintenance agreements should be enacted between private party and public agency.



Commercial Streets

Commercial Streets are higher vehicular traffic thoroughfares that connect across districts. They should have enhanced pedestrian realm, including landscape buffers and on-street parking that protect pedestrians from vehicles. Infill development should minimize and consolidate driveways and access points to reduce pedestrian-vehicle conflict points. Ensuring infill development along these streets improves land uses and provides high-quality design will be critical.

Examples in Downtown:

- Broadway Street
- West Third Street
- Chester Street



Residential Streets

Residential Streets are low vehicular traffic streets that have very slow travel speeds and have primarily residential land uses. These streets should prioritize walking with sidewalks that are at least 5' wide and with wide landscape buffers for street trees. They should have on-street parking zones and can have bike lanes. Curb-to-curb widths and travel lanes should be narrow to ensure slow traffic.

Examples in Downtown:

- Sherman Street
- Pulaski Street
- Cross Street



Green Streets

Green Streets are priority corridors that can have a variety of land use and vehicular traffic patterns, depending on their location. They are key corridors that prioritize moving pedestrians and cyclists to the Arkansas River and other parks and open spaces. They should have enhanced pedestrian realm, including protected bike lanes and landscape buffers that include integrated stormwater infrastructure such as bioswales and rain gardens.

Examples in Downtown:

- Center Street
- West 2nd Street
- State Street

Dimensional Standards and Intersection Design

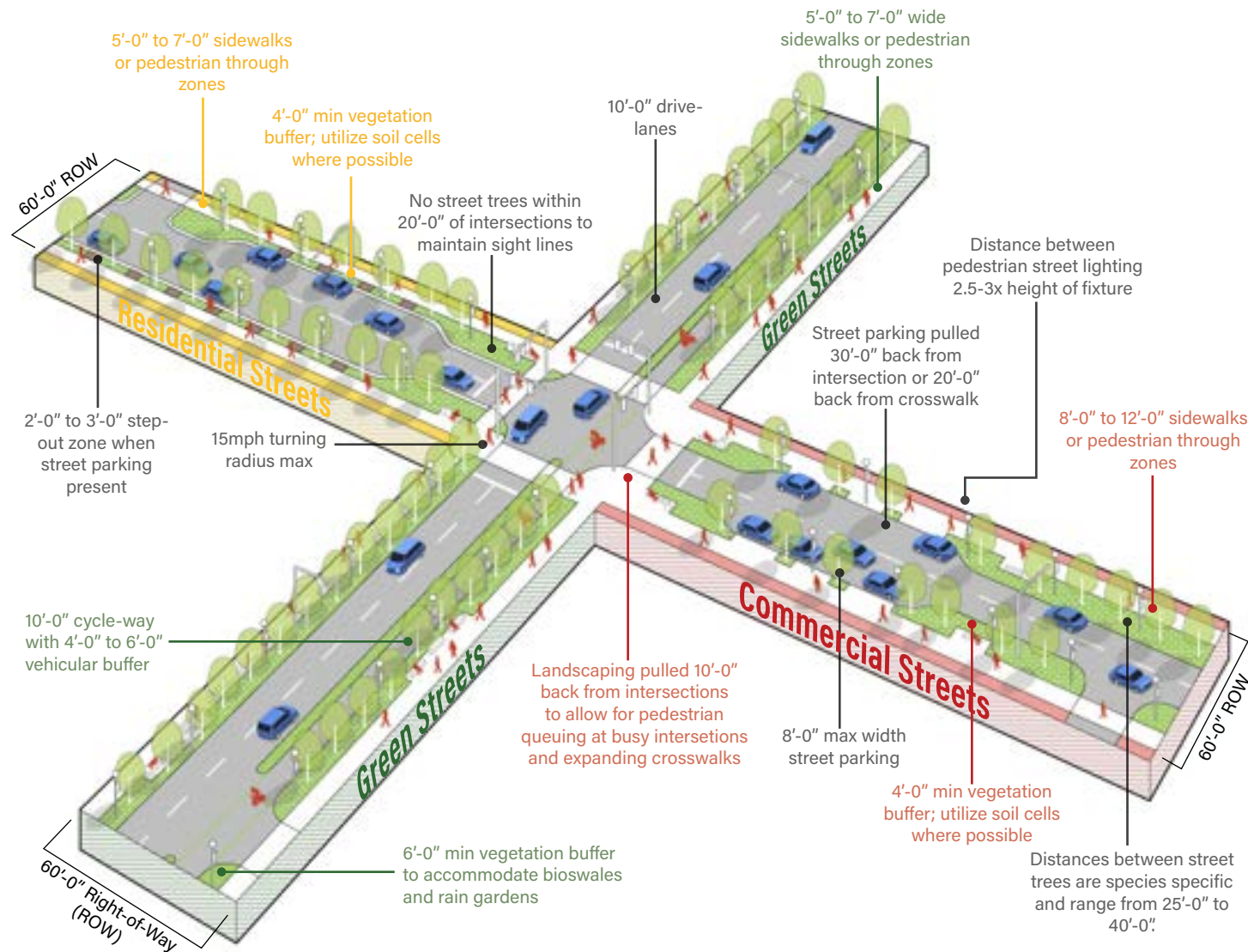

Source: "National Association of City Transportation Officials", May 6, 2024, <https://nacto.org/>.

Human-Scaled Street Design

Well-designed downtown streets prioritize pedestrian movement and safety and other forms of mobility, while still allowing for vehicular movement and necessary service and loading. Downtown Little Rock's are mostly 60 foot wide right-of-ways. This ensures a sense of enclosure needed for good urban design but also means different streets will need to prioritize different infrastructure elements due to limit width. Ensuring lane widths that are no wider than 10' will allow more room for other forms of movement. Regular street trees should be prioritized on all streets, while Green Streets prioritize stormwater infrastructure and bike movement. Commercial and Green Streets have wide sidewalks due to heavier pedestrian movements and surrounding land uses.

Do this...



Not that...



Create definition in the roadway using striping, cycle tracks, and narrow travel lanes. Physically separate different modes of travel.

Provide ample sidewalk space for pedestrians to travel without obstructions. Strategically utilize setbacks in new developments for outdoor dining or front porches that do not conflict with pedestrian through zones.

Utilize an advanced stop bar located at least 8'-0" in advance of the crosswalk to reinforce yielding to pedestrians. In cases where bicycles frequently queue in the crosswalk or may benefit from an advanced queue, a bike box should be utilized in place of or in addition to an advanced stop bar.

Utilize curb extensions, tight corner radii, cycle tracks, and pedestrian safety islands where appropriate that force drivers to navigate intersections cautiously.

Delineate guide markings through intersections to reduce conflicts and guide turning vehicles.

Loading, Access, Drop-Offs, and Transit

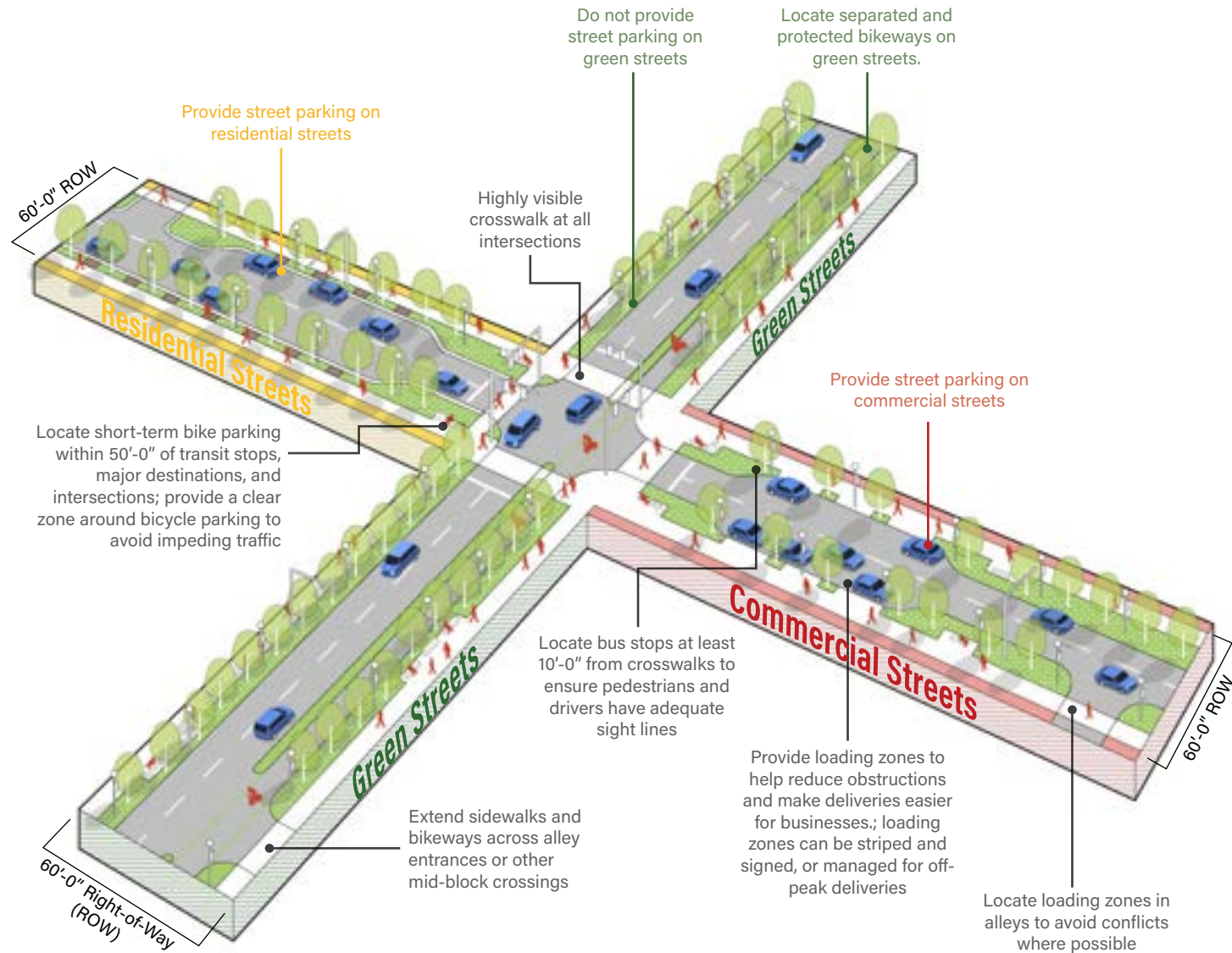

Designing for Function

Although Downtown streets should prioritize pedestrian and multimodal movement and safety, they must still be designed to enable vehicular movement, loading for businesses, and curbside access for vehicular dropoff. Thoughtful design along with adequate enforcement of curbside policies can ensure that these daily service needs do not have a detrimental effect on walkability.

Source: "National Association of City Transportation Officials", May 6, 2024, <https://nacto.org/>.

Do this...



Not that...

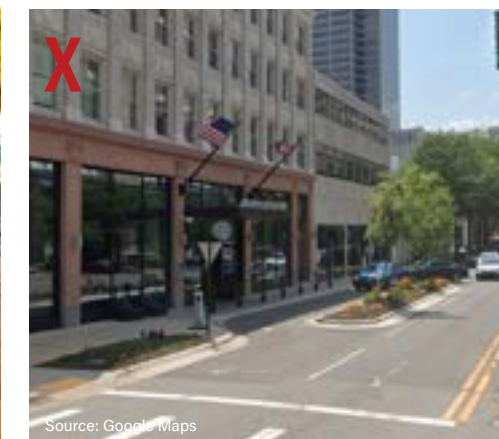

Provide dedicated areas for trucks, bikes, scooters, etc. to un/load, especially on commercial streets. Utilize clear signage, markings, and protection. Set time limits (about 10 minutes max) to enable turnover and quick access to essential services. Where possible, locate un/loading in alleys.

Ensure valet and other drop-off services do not conflict or hinder pedestrian through zones, normal vehicular traffic, bikeways, etc.

Extend sidewalks and bikeways (via markings, paving, raised curbs, etc.) across alley entrances or other mid-block crossings to slow vehicles and promote pedestrian / cyclist safety.

Utilize curbside pull-out stops (also called bus-bulbs) as a low-cost option for bus stops on streets with curbside parking. Locate bus stops at least 10'-0" from crosswalks to ensure pedestrians and drivers have adequate sight lines.

Amenities

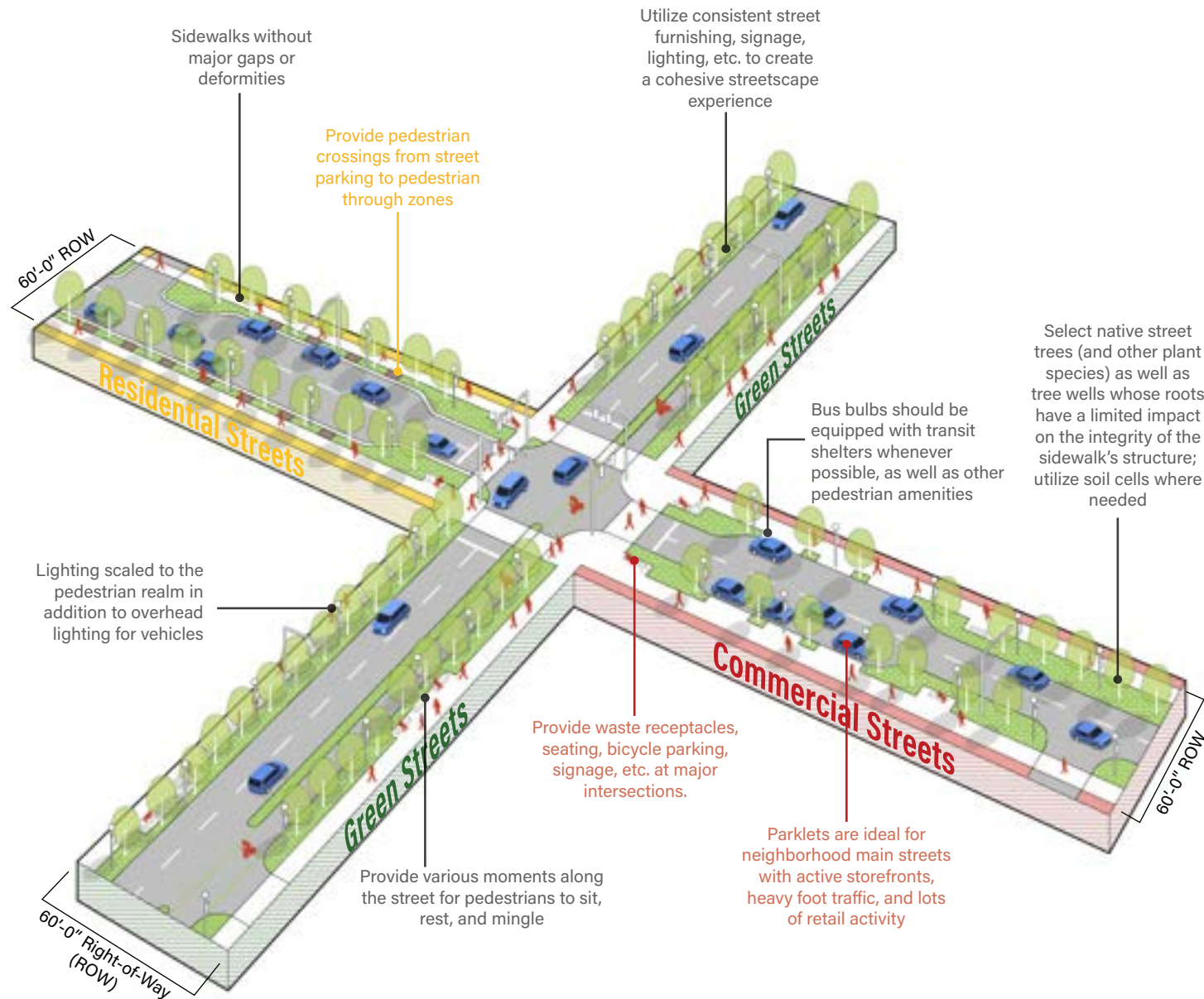

Designing for Comfort

A well-designed urban street is great because it is a comfortable experience. Wide, well-lit sidewalks, highly-visible crosswalks, adequate signal timing to cross intersections, shade from street trees, and consistent building edges all contribute to a comfortable walking experience. The outlined design recommendations above are all essential for ensuring an experience that encourages and promote walking. Additional street elements such as street furniture, consistent materials and lighting, and well-marked transit also contribute to a positive pedestrian experience.

Source: "National Association of City Transportation Officials", May 6, 2024, <https://nacto.org/>.

Do this...



Not that...

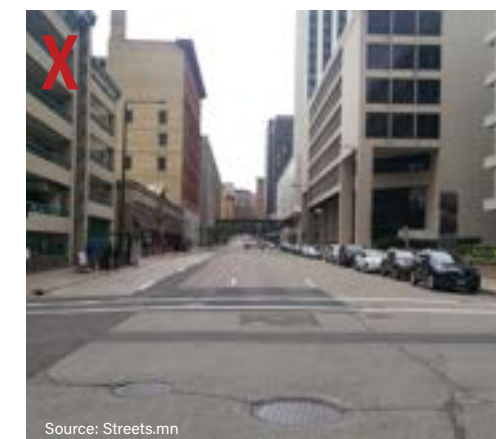

Sidewalks should prioritize human comfort and scale, as well as be vibrant collections of public art, cafés, benches, trees, awnings, signage, etc.

Bus bulbs should be equipped with transit shelters whenever possible and may be combined with amenities such as wayfinding maps, plantings, and trees to enhance the overall transit user experience.

Utilize native trees and understory plantings to provide shade, support eco-system services, slow traffic, and contribute to the overall beauty of Downtown Little Rock.

Ensure street furnishing and other amenities are inclusive

Strategy 1A

Construct the missing segment of the Arkansas River Trail, the final leg of the Southwest Trail and formalize design and construction of the Rose Creek Greenway

Lead Implementer:	City of Little Rock Parks; City of Little Rock Public Works; Private development
Other Groups:	Union Pacific Railroad (UPRR); State of Arkansas; ARDOT; Private Development
Timeline:	Ark River Trail: Short-Term (1-3 Years); Other Trails: Medium Term (4-8 Years)
Funding Sources:	City General Fund; Arkansas Transportation Alternatives Program Grant; Arkansas Recreational Trails Program Grant; Federal FLAP Grants; Philanthropy



Strategy 1B

Begin planning and potential land acquisition or easement negotiations for additional trail corridors in Downtown

Lead Implementer:	City of Little Rock Parks; City of Little Rock Public Works
Other Groups:	ARDOT; State of Arkansas; Private development
Timeline:	Medium Term (4-8 Years)
Funding Sources:	City General Fund; Arkansas Transportation Alternatives Program Recreational Trails Program; Arkansas Transportation Alternatives Program Grant; Arkansas Recreational Trails Program Grant; Federal FLAP grants; Philanthropy



Strategy 1C

Shift management and ownership of public trails from City of LR Public Works to City of LR Parks Department, shifting requisite funding from Public Works to Parks accordingly

Lead Implementer:	City of Little Rock Public Works; City of Little Rock Parks & Recreation
Other Groups:	City of Little Rock Board of Directors
Timeline:	Short-Term (1-3 Years)
Funding Sources:	None Required

Currently, the City of Little Rock's Public Works Department manages and maintains recreational trails, even in city parks. This is a highly unusual operational structure that was cited to create problems for trail maintenance and park operations. As a recreational asset for the parks system, trails should be maintained concurrent with park maintenance. The funding dedicated towards trail maintenance within the Public Works budget should be reallocated to the Parks and Recreation Department to ensure adequate funding. This will allow those monies to aid in trail-adjacent programming such as signage, furniture, and landscaping



Arkansas River Trail in Riverfront Park

Strategy 2A

Create a new Downtown Parks Conservancy to serve as a philanthropic support organization for park and trail enhancements

Lead Implementer:	City Parks Conservancy; City of Little Rock Parks & Recreation
Other Groups:	Downtown Partnership; Philanthropy
Timeline:	Short Term (1-3 Years)
Funding Sources:	Minimal funding required; Philanthropy to initiate creation of non-profit

- 1 Leverage the City Parks Conservancy, in partnership with the Parks Department and Downtown Partnership, to explore creation of a Downtown Parks Advocacy Group.
- 2 Leverage existing City Parks Conservancy, a newly formed Downtown Parks Advocacy Group, and private philanthropy to create a dedicated non-profit or effort within the City Parks Conservancy supporting enhancements to Downtown parks.
- 3 Consider the creation of a Downtown Parks and Trails Master Plan in the future should funding be available.

What Is a Parks Conservancy?

A 501c3 non-profit whose goal is to advance long-term development of new parks and trails while supporting existing park enhancements.

The City Parks Conservancy is an existing organization in Little Rock whose goal is "to maintain city parks, provide a safe environment for all visitors, and [provide] financial support for the regular maintenance and upkeep" of all parks in the city.

How Would This Work?



Strategy 2B

Collaborate with the State of Arkansas to reimagine portions of the State Capitol Grounds as functioning public open space with recreation space, trails, and a visitor center

Lead Implementer:	City of Little Rock; State of Arkansas
Other Groups:	New Parks Conservancy
Timeline:	Medium-Term (4-8 Years)
Funding Sources:	Federal FLAP Grants; State of Arkansas funding

- 1 Collaborate with the Capitol Arts and Grounds Commission to identify tactical open space interventions, including opportunities to construct the Southwest Trail on the west side of grounds
- 2 Initiate conversations with State Parks to consider opportunities for an on-site visitor center
- 3 Identify state-owned land for disposition for redevelopment. Leverage a portion of tax revenue generated from redevelopment to fund open space enhancements
- 4 Long-term, a master plan for State Capitol should be initiated to guide long-range redevelopment



Strategy 2C

Reimagine the 18-acres of ARDOT land leftover from the 30 Crossing project into a grand central park for all of Central Arkansas

Lead Implementer:	City of Little Rock; ARDOT
Other Groups:	Private Development; CALS, HAM, Museum of Discovery, Clinton Library
Timeline:	Short-Term (1-3 Years)
Funding Sources:	City Sales Tax Increase; Neighborhood Access and Equity Grant Program; USDOT Reconnecting Communities and Neighborhoods Grant; Philanthropy; Special Tax District; TIF Funding; Mellon Foundation Monuments Program

- 1
- 2
- 3

1 Create a special purpose taxing or TIF district around the Park to direct redevelopment tax generation and potential portions of sales tax to fund park operations, maintenance, and improvements

2 Strategically dispose of and redevelop available publicly-owned land around park to serve as catalytic tax increment for the taxing district and to activate the park once complete.

3 Actively pursue Federal and State grants and private philanthropy to assist with project financing.

The 18-acres left over from the removal of off-ramps through the reconstruction of Interstate 30 presents a transformational opportunity to create a regional park for all of Central Arkansas. There are countless examples from around the country, including Omaha and Oklahoma City, where new parks were able to catalyze massive amounts of economic development due to the vibrancy these parks attract. This park opportunity should provide a host of programming for all ages and should be strongly connected to the surrounding museums and cultural amenities such as the Central Arkansas Library, Historic Arkansas Museum, Museum of Discovery, and Clinton Library, giving them the opportunity to expand their programming into the park. The Park should consider telling Arkansas Indigenous Peoples



history, including a museum or memorial to commemorate those people and the Trail of Tears, which passed through Little Rock. The Park should also have a strong connection to the Arkansas River, connecting people to the water. Building new, thriving urban parks requires extensive programming and maintenance and are expensive to operate. It will be critical for the City of Little Rock to create dedicated revenue streams and unique management strategies that are separate from standard Parks and Recreation Department budgets and standard management to ensure the park's long-term success. The ideas on Page 188 should serve as a starting point for design and programming considerations. Specific design details and locations will be determined at a later phase.

A Special Purpose Tax District or Tax Increment Finance (TIF) District should be established around the park, strategically including future redevelopment parcels, including some of the right-of-way leftover from the highway removal. The new tax revenue generated in this district from redevelopment can be directed back into park's operations and maintenance and ensure a permanent funding stream that does not drain the City's General Fund.

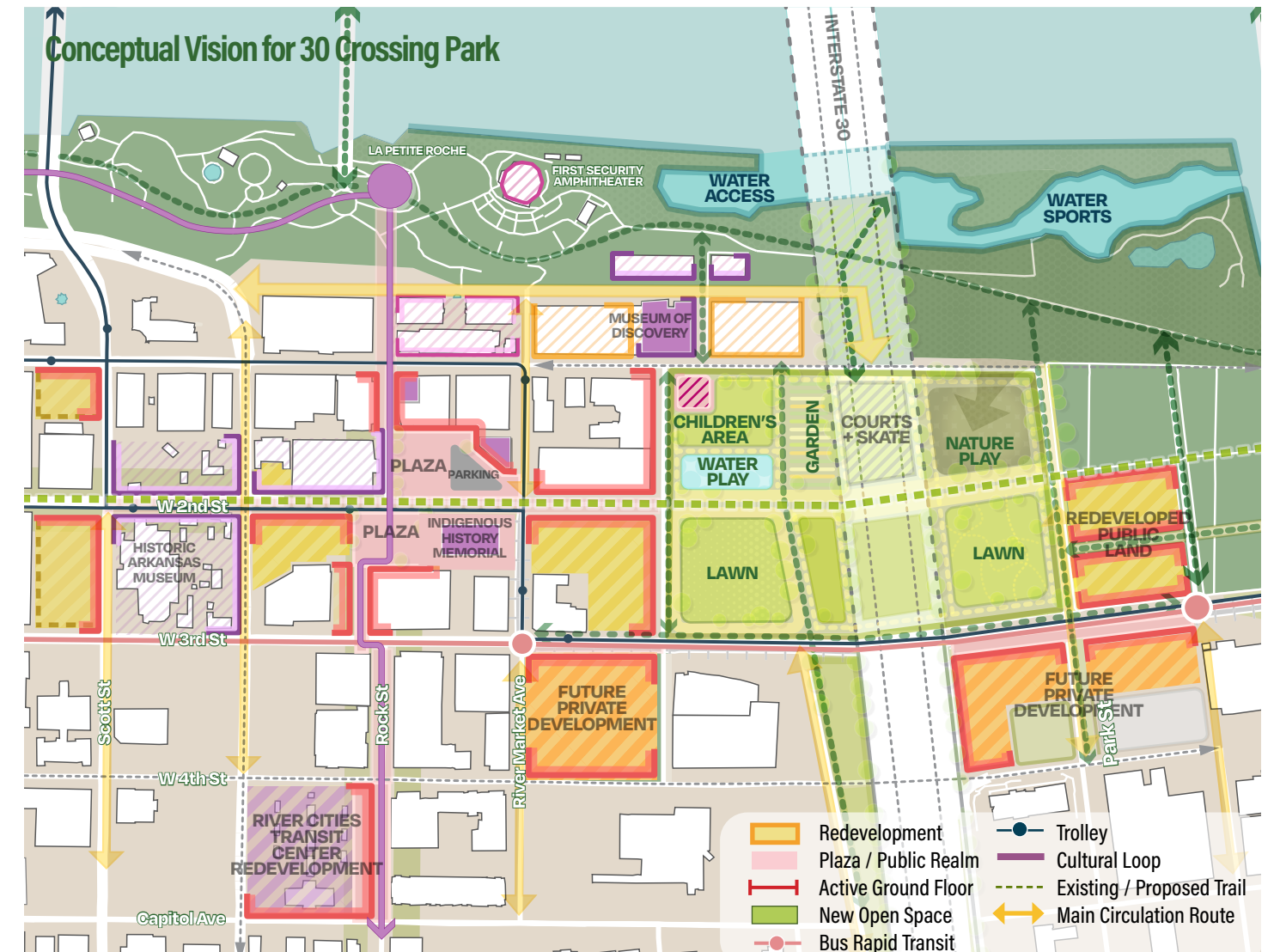
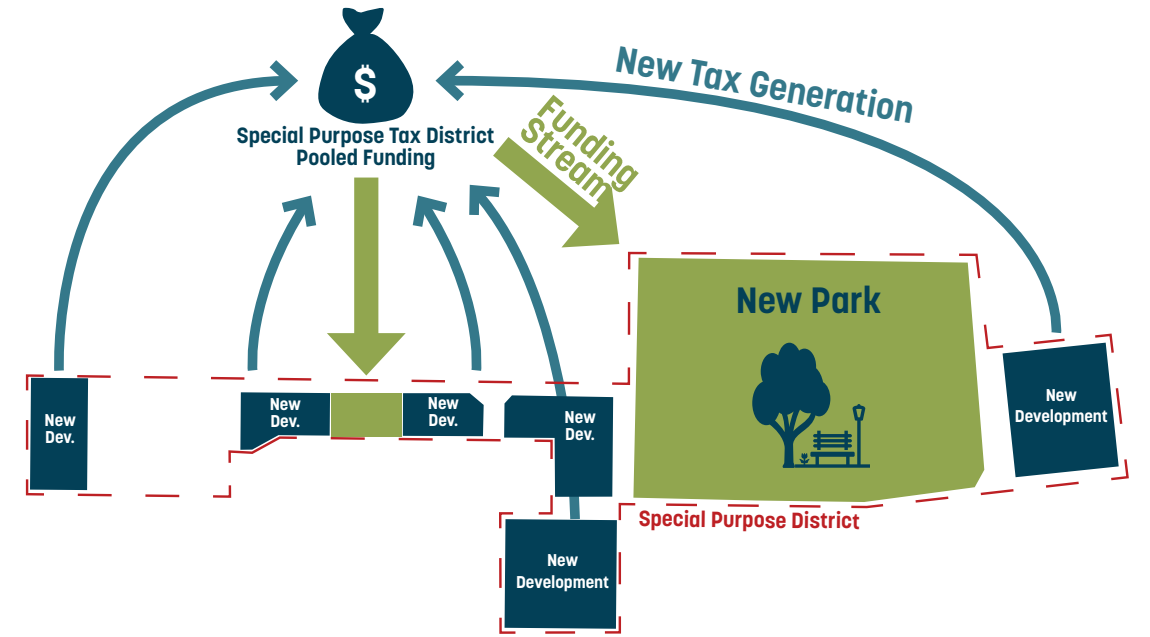

Strategy 3A

Reimagine LaHarpe Blvd. and Cumberland St. between Chester, President Clinton Ave., and 4th Street as a slow, two-lane shared street, reimagining leftover right-of-way as open space and development opportunities

Lead Implementer:	City of Little Rock Public Works; City of Little Rock Parks; ARDOT
Other Groups:	Adjacent Property Owners
Timeline:	Planning should begin immediately. Implementation is Medium-Term (4-8 Years)
Funding Sources:	Neighborhood Access and Equity Grant Program; USDOT Reconnecting Communities and Neighborhoods Grant; Future City Bond

- 1** Initiate conversations with ARDOT to remove LaHarpe from ARDOT control, conducting necessary traffic studies as needed
- 2** Begin tactical closures of roadway on weekends to highlight the opportunity.
- 3** Close one side of roadway to traffic, implementing necessary roadway and signal modifications
- 4** Implement a phased reconstruction of the full corridor, with a preferred Phase 1 to be between the Marriott Hotel and Arch St.

LaHarpe Boulevard's high-speed design, along with grade challenges and physical barriers, create significant challenges in connecting the core of Downtown to the river. Removing it from the State highway network and reimagining it as a City-managed two-lane parkway will allow the road to function as a neighborhood street, enhancing connectivity along it.

In the short-term, temporary weekend closures could help turn the roadway back over to pedestrians while also testing the viability of long-term lane reduction and reconstruction. Long-term, a reconstructed two-lane LaHarpe should connect to Ottenheimer Plaza in the River Market, creating a continuous, slow-speed parkway along the river's edge from Chester Street to Interstate 30.

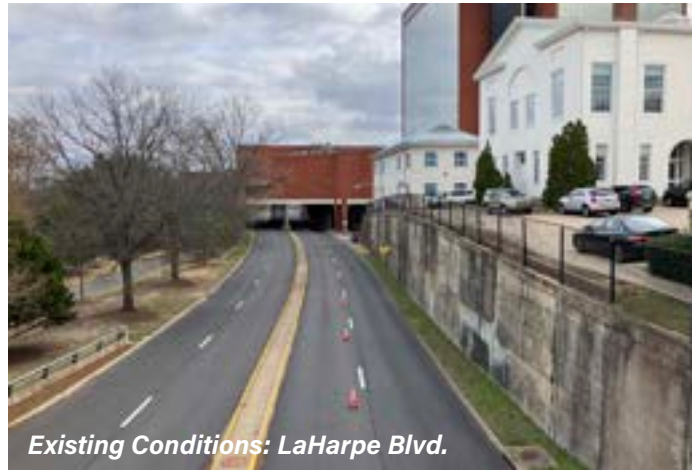

A reimagined cross-section for LaHarpe creates a ceremonial parkway through Riverfront Park

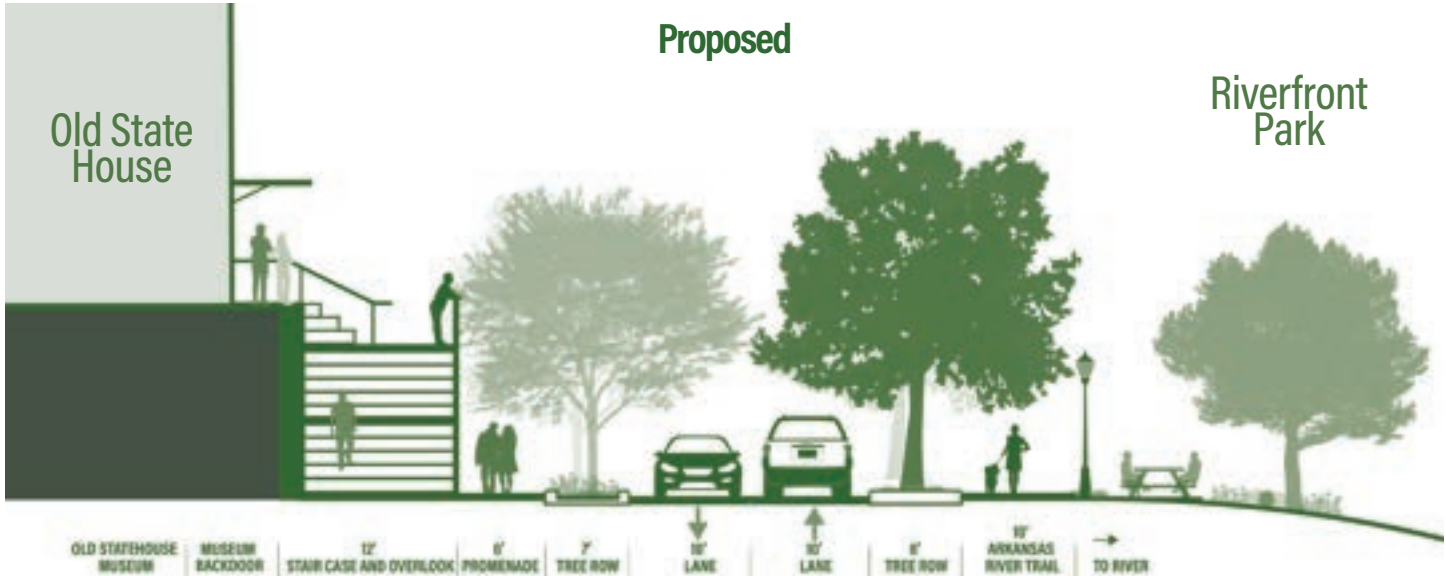
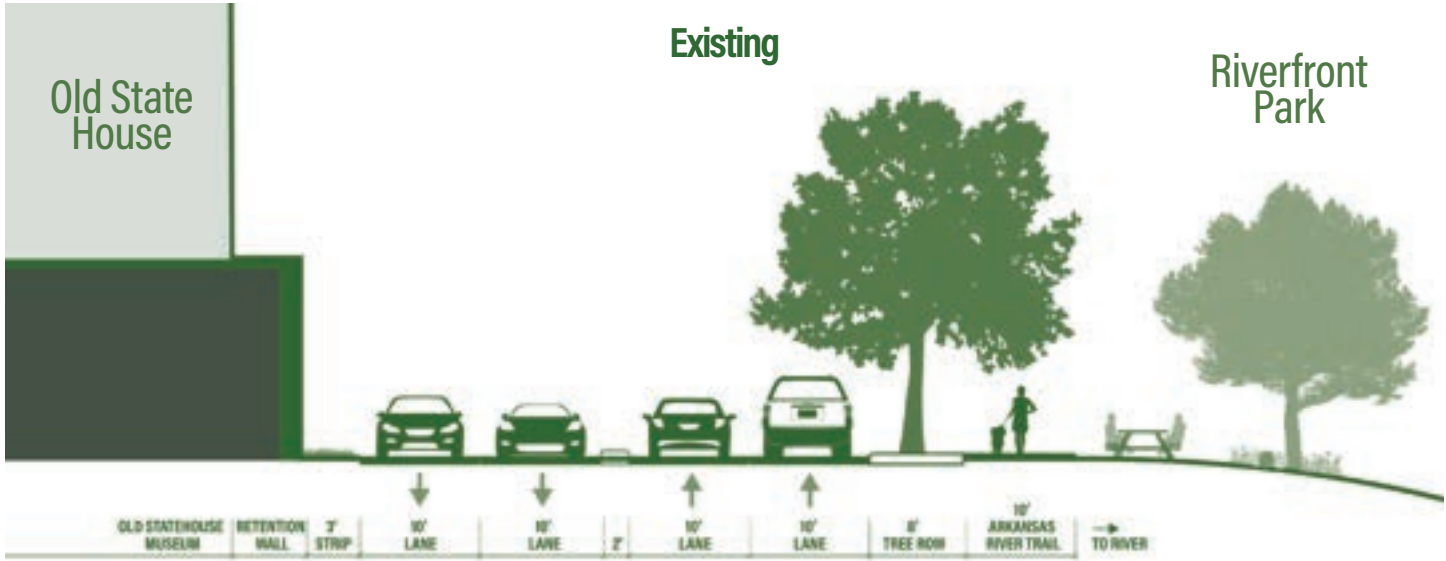

Strategy 3B

Develop a facade incentive program for all existing buildings facing the River, providing small grants to incentivize changes to the river-facing side of their building

Lead Implementer:	City of Little Rock
Other Groups:	Existing Property Owners
Timeline:	Medium-Term (4-8 Years)
Funding Sources:	TIF funding; Other Incentives Funding Tools (if created)

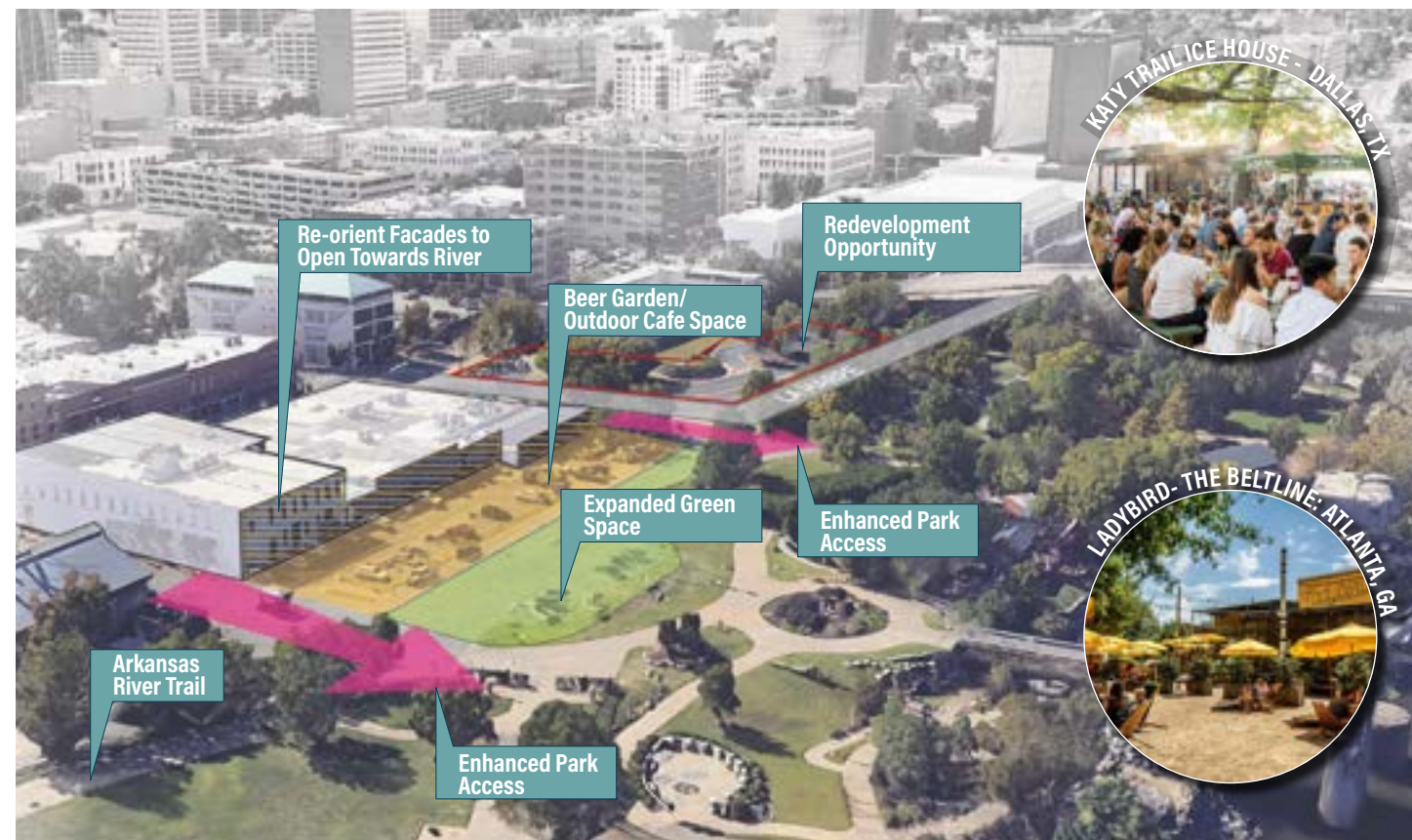
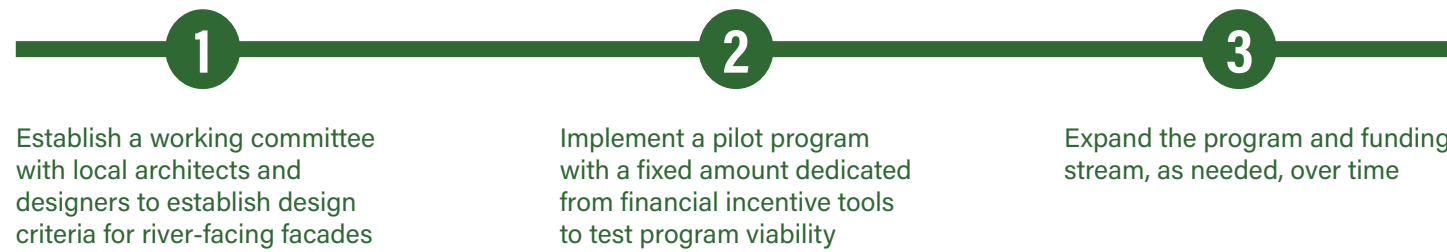

Critical to enhancing the City's connection to the river is to improve existing buildings along the river. A new facade program should be created to provide funding and design support for reimagining the way existing buildings engage with Riverfront Park. Existing parking lots should also be reimagined as new open space and private dining space.

Strategy 3C

Reimagine and redevelop city-owned and state-owned land along the Arkansas River into mixed-use development

Lead Implementer:	City of Little Rock; State of Arkansas
Other Groups:	Private Development
Timeline:	Short-Term (1-3 Years)
Funding Sources:	TIF Funding (as needed); private equity

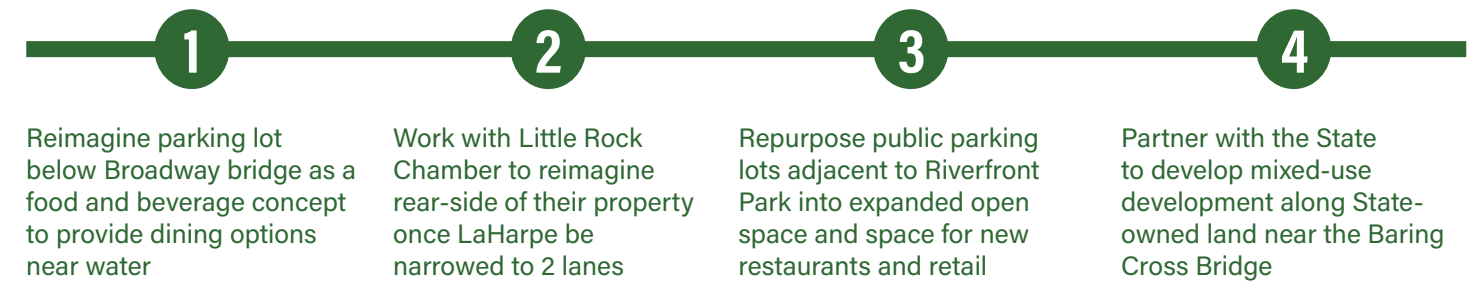



Strategy 4A

Pursue Department of Energy grant for smart grid enhancement to support growth, system electrification, and support for EV vehicle charging

Lead Implementer:	Entergy; Downtown Partnership
Other Groups:	City of Little Rock
Timeline:	Short-Term (1-3 Years)
Funding Sources:	US Department of Energy: Grid Resilience Utility and Industry Grants

As a center of commerce and one of the densest areas in the State, Downtown should epitomize sustainability. The US Department of Energy's Grid Resilience and Innovation Partnerships (GRIP) Program and Grid Resilience Utility and Industry Grants provide funds to electric grid operators to modernize the grid. In addition to improved grid reliability and resiliency, this funding opportunity apportions funding for associated community benefits initiatives. Entergy is partnering with key partners within the community to provide funding for things such as non-profit grant writers, additional paid internships, social worker stipends, LED lighting retrofits, marketing for energy efficiency programs, and college course scholarships.



Source: Little Rock Public Radio



Strategy 4B

Establish a Downtown tree planting program to establish new canopy within public realm and within ARDOT right-of-way, and improve surface parking lot landscaping

Lead Implementer:	Tree Streets Little Rock; Downtown Partnership
Other Groups:	City of Little Rock Public Works, Parks & Recreation; ARDOT
Timeline:	Short-Term (1-3 Years)
Funding Sources:	Arkansas Urban and Community Forestry Grant

1

Leverage Tree Streets Little Rock to conduct a survey of dead trees or empty tree wells on all streets north of I-630 in Downtown

2

Prioritize existing tree wells and areas with existing irrigation for priority plantings, coordinating with adjacent property owners as needed

3

Leveraging City funds and State grants, create an annual cycle for eligible property owners to receive trees for parking lots and public realm if they agree to maintain them



Strategy 1A

Establish a new campaign promoting tourism and activity in Downtown, using the Tourism Master Plan as a guide

Lead Implementer:	Downtown Partnership
Other Groups:	Little Rock Convention and Visitors Bureau (LRCVB); State of Arkansas
Timeline:	Immediate (0-2 Years)
Funding Sources:	State of Arkansas Tourism Attraction Matching Grant; Downtown Partnership Annual Budget; LRCVB Annual Budget; City of Little Rock General Fund

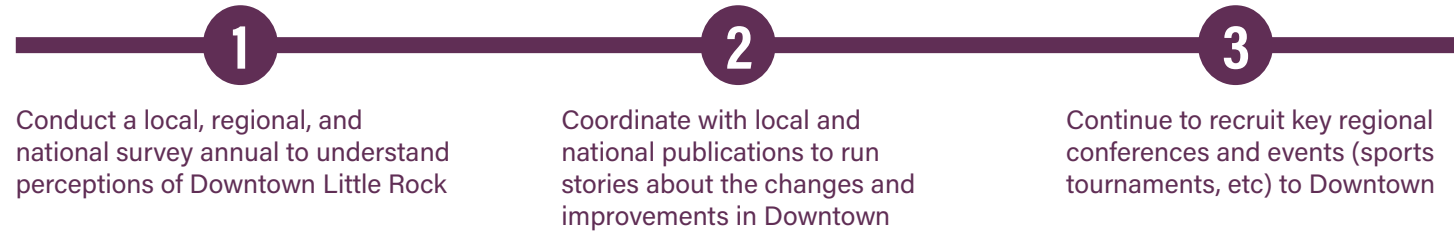

Even with the many exciting projects and events happening in Downtown, the district has a negative perception problem within Little Rock, Central Arkansas, and the State. These perceptions center around concerns about safety, homelessness, and lifelessness. Although some of these concerns are valid, many do not align with the facts. Crime is much lower than many areas of the City, and several neighborhoods such as SOMA have thriving restaurant and entertainment scenes. These present an opportunity for a broad-reaching promotional campaign.

The Downtown Partnerships, working with the Little Rock Convention and Visitor's Bureau and State of Arkansas should pursue internal and external funding to leverage



Source: Arkansas Times

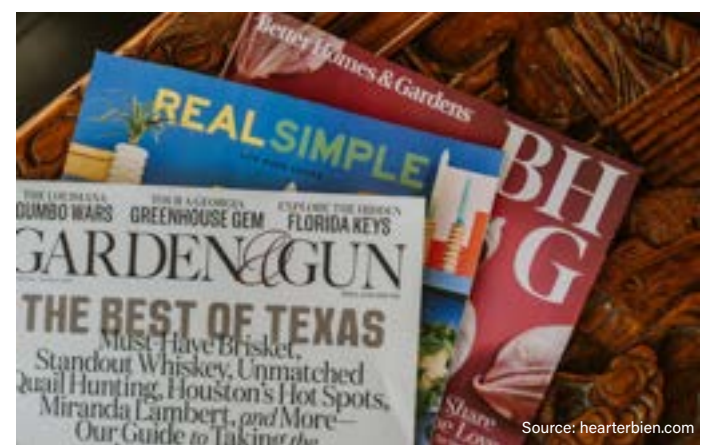

Source: hearterbien.com

existing tourism campaigns and to lead a new, national campaign that champions the opportunities for tourism in Downtown Little Rock. This should include articles and advertisements in national and regional publications.

At the same time, a more targeted local effort should be undertaken to promote positive stories in Downtown, proactively working with local publications to change the narrative, promoting Downtown as a safe, family-friendly destination. These will be critical to driving local foot traffic to parks, restaurants, and entertainment. Key to all of this is establishing an annual perceptions survey to track local, regional, and national perceptions to monitor if the campaign and development is having a positive impact.

Strategy 1B

Establish Downtown-wide and individual district branding and promotional materials, including new wayfinding and signage.

Lead Implementer:	Downtown Partnership
Other Groups:	LRCVB; City of Little Rock
Timeline:	Short-Term (1-3 Years)
Funding Sources:	National Endowment of the Arts Placemaking Grant; Arkansas Historic Preservation Program Main Street Public Art Grant program



In conjunction with a broad-reaching tourism and promotional campaign, Downtown Little Rock should explore new branding for the entire district and for the distinct neighborhoods. This will help to give a physical, graphical manifestation to the changes occurring in Downtown. In order to establish this district and neighborhood branding, a new Promotion and Branding Taskforce should be established by the Downtown Partnership. This group will outline a vision for Downtown branding and should serve as a starting point for establishing neighborhood-specific focus groups or committees. The more important aspects for a rebrand for Downtown is consistency across all of the neighborhoods so that, even though each area's unique's attributes are represented, they feel collectively to be one



Source: cycle905.blogspot.com



Source: Luminant Design

brand. Over time, this will become something well-known locally and nationally. Once a branding identify has been established, new signage, including light pole banners, and wayfinding should be funded and installed around Downtown. This will not only help encourage mobility between Downtown's neighborhoods but will also reinforce the Downtown brand. The Downtown Partnership should partner with LRCVB to leverage planned wayfinding enhancements to deliver improved, refreshed branding and signage.

Upper Right: District wayfinding signage in Indianapolis
Left: District wayfinding signage in Downtown Portland



Strategy 2A

Establish a Downtown Public Events Revolving Fund and a Public Art Fund to finance public events and public art within Downtown

Lead Implementer:	Downtown Partnership
Other Groups:	AMFA; Arkansas Reperatory Theater; Other Art/Culture Institutions; Artists
Timeline:	Medium Term (4-8 Years)
Funding Sources:	Philanthropy; Arkansas Arts Council Grants (Community Arts Project Grant); Arkansas Historic Preservation Program Main Street Public Art Grant program

Downtown’s numerous events are highly popular by all of Central Arkansas. In addition to large events like the Main Street Food Truck Festival, the Downtown Partnership has also been responsible for numerous pieces of public art and murals installed around the district. Enhancing and expanding existing events attracts new visitors to the area and provide additional positive messaging for promotion. Much as the Downtown Partnership has leveraged alcohol sales at events to pay for mural installations, using seed money to establish a revolving fund could enable organizations and artists to use these dollars for events, physical installation, and performances.

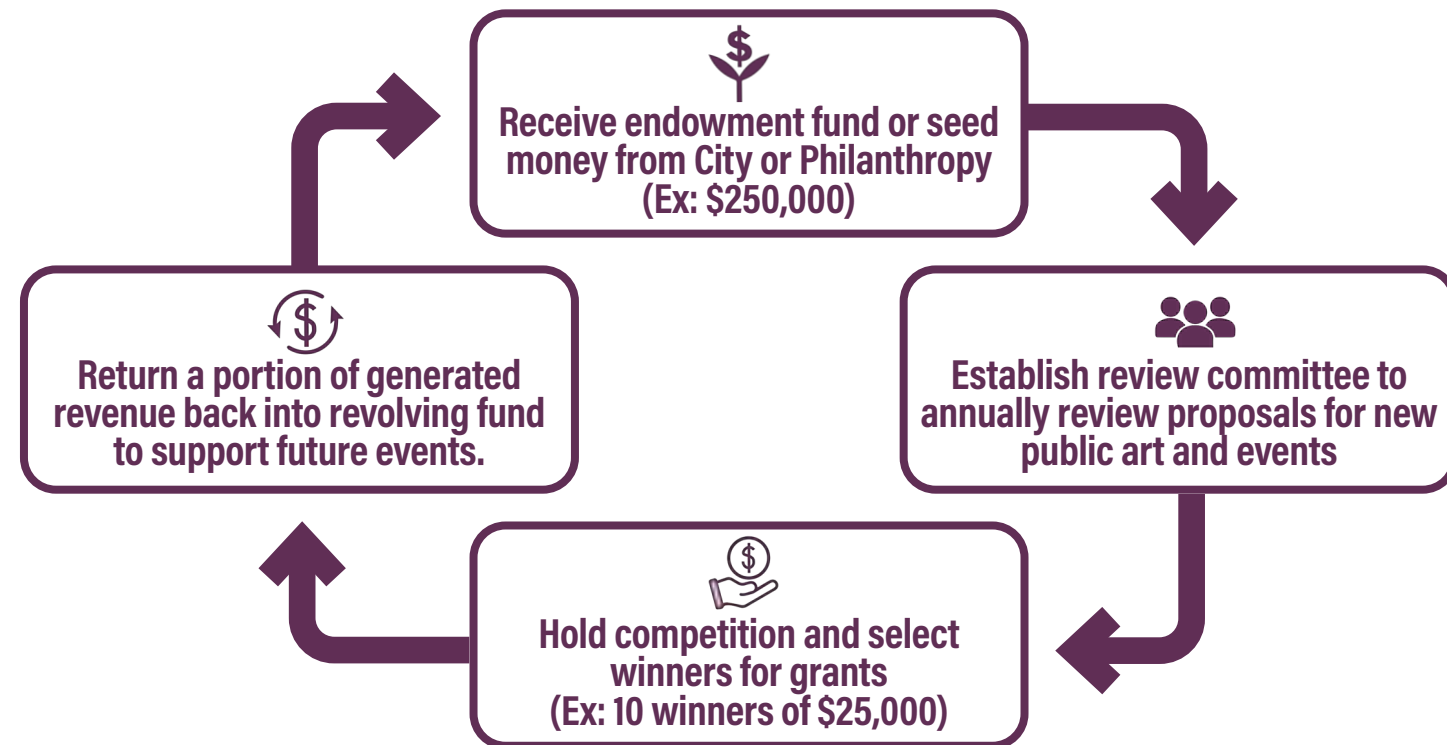

Strategy 2B

Collaborate with ongoing local events such as Central Arkansas Pride, the Big Dam Bridge 100, and Big Bass Bonanza to return to Downtown Little Rock, reducing permit fees and easing coordination as needed

Lead Implementer:	LRCVB; Downtown Partnership
Other Groups:	Local Event Organizers
Timeline:	Short-Term (1-3 Years)
Funding Sources:	No Funding Required

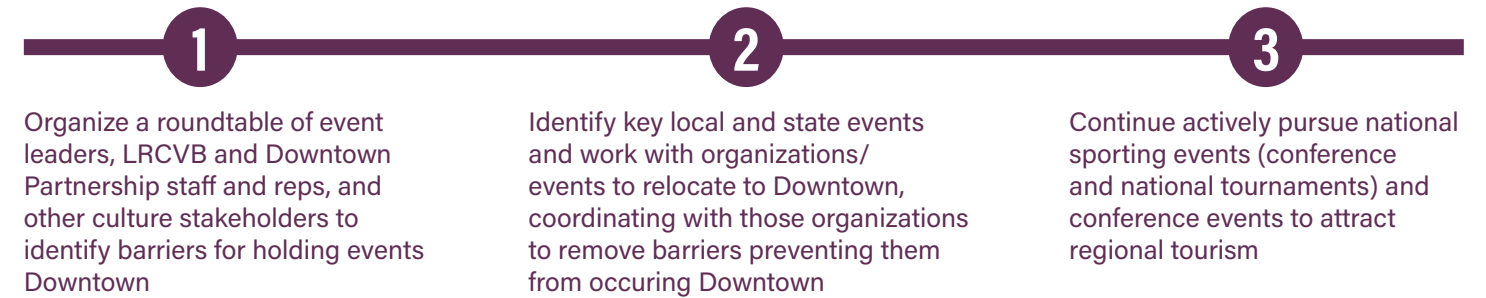

Strategy 2C

Construct an Indoor Sports and Recreation Facility in Downtown to create a new center for the community and drive tourism activity.

Lead Implementer:	City of Little Rock
Other Groups:	Private Groups To Be Determined in Future
Timeline:	Medium Term (4-8 Years)
Funding Sources:	Local Sales Tax Increase Measure

Creating a destination indoor sports and recreation complex for all Little Rock residents and out-of-town visitors will enhance the sense of community and enhance vibrancy and activity, supporting local hotels and retail in the process. It will also enhance Downtown residents’ quality of life by providing additional recreation amenities. A new facility should be located in the heart of existing activity, near the River Market and East Village. This will create a walkable destination from existing and new hotels while also having easy access to Interstate 30. Potential locations that should be considered are vacant land east of the Heifer International Campus and the existing US Postal Service facility on Capitol Avenue.



Strategy 3A

Establish a Black Entrepreneurship and Incubator Hub located on West Ninth Street to provide affordable space for start-up businesses.

Lead Implementer:	Mosaic Templars Cultural Center; City of Little Rock
Other Groups:	Philander Smith University; UALR; CALS; Little Rock Tech Park; ReMix Ideas
Timeline:	Short-Term (1-3 Years)
Funding Sources:	Private Philanthropy; Arkansas Heritage Office funding; Mellon Foundation Humanities in Place Grant program; National Endowment of Arts grants

1

Establish a new dedicated 501c3 non-profit whose goal is the creation of a new center. Alternatively, leverage an existing non-profit to fulfill the same role.

2

Identify potential partners, including the City, local universities, and the Mosaic Templars Cultural Center.

3

Fundraise and pursue grants, with the goal of developing a hub in the next five years. This should include pursuing purchasing of an existing building on West Ninth.

Due to the construction of Interstate 630 in the 1970's and 80's, the history and significance of West Ninth Street has largely been lost to history. But still, the corridor is home to numerous anchors, including the Mosaic Templars Cultural Center (MTCC), The Hall, and Dreamland Ball, a historic space operating as an event venue. A new Black Entrepreneurship and Innovation Hub should serve as another anchor for the corridor. This would bring new visitors, businesses, food options, and vibrancy to the area.

A new Black Entrepreneurship and Innovation Hub should include coworking space, leasable office space that should be prioritized for minority-owned non-profits and businesses, a commercial kitchen for start-up restaurants, and community meeting rooms and gathering spaces. Future expansion could also include performing arts spaces and artist galleries. This future expansion could remember the Historic Gem Theater once located on West Ninth and name the space "The Gem".

A new facility will be an expensive undertaking, so it may be designed in phases. Phase One should explore a collaborative partnership of the MTCC (State of Arkansas Heritage Office), the City, a potential new non-profit organization, and local higher education institutions to purchase an existing structure along the street. A primary site that should be considered is the one-story retail building located at the southeast corner of Arch Street and Ninth Street. Due to its location, this building could expand south in the future into its current parking lot. Between this building and MTCC, a new plaza should be



constructed. This public space could honor John Carter, who was lynched near the spot in 1927. This space could also become a vibrant plaza, activated by the museum and the proposed Entrepreneurship and Innovation Hub. Patio seating for the restaurant incubator hub and a performance stage could anchor the plaza.

Other Improvements on West Ninth Street should include enhanced streetscape to make the corridor more walkable. This includes wider sidewalks, street trees, and signage as a part of the Cultural Loop. The area should also consider the creation of a shared parking lot to be used by MTCC, The Hall, The Hub, and other future users, leveraging State-owned, underutilized ARDOT property southwest of MTCC. A vacant, triangular piece of land at the southwest corner of State Street and West Ninth, currently owned by ARDOT, is a prime opportunity to create a dedicated greenspace along the corridor. This piece of land, which was once part of a vibrant neighborhood which was taken from Black families for the construction of Interstate 630, could become a gathering space adjacent to the State Street bridge, which is proposed to be closed to vehicular traffic to create a safe, predominant crossing between Philander Smith and West Ninth. This new green space could also become the location of a memorial or commemorative landscape that tells the history of the West Ninth corridor.

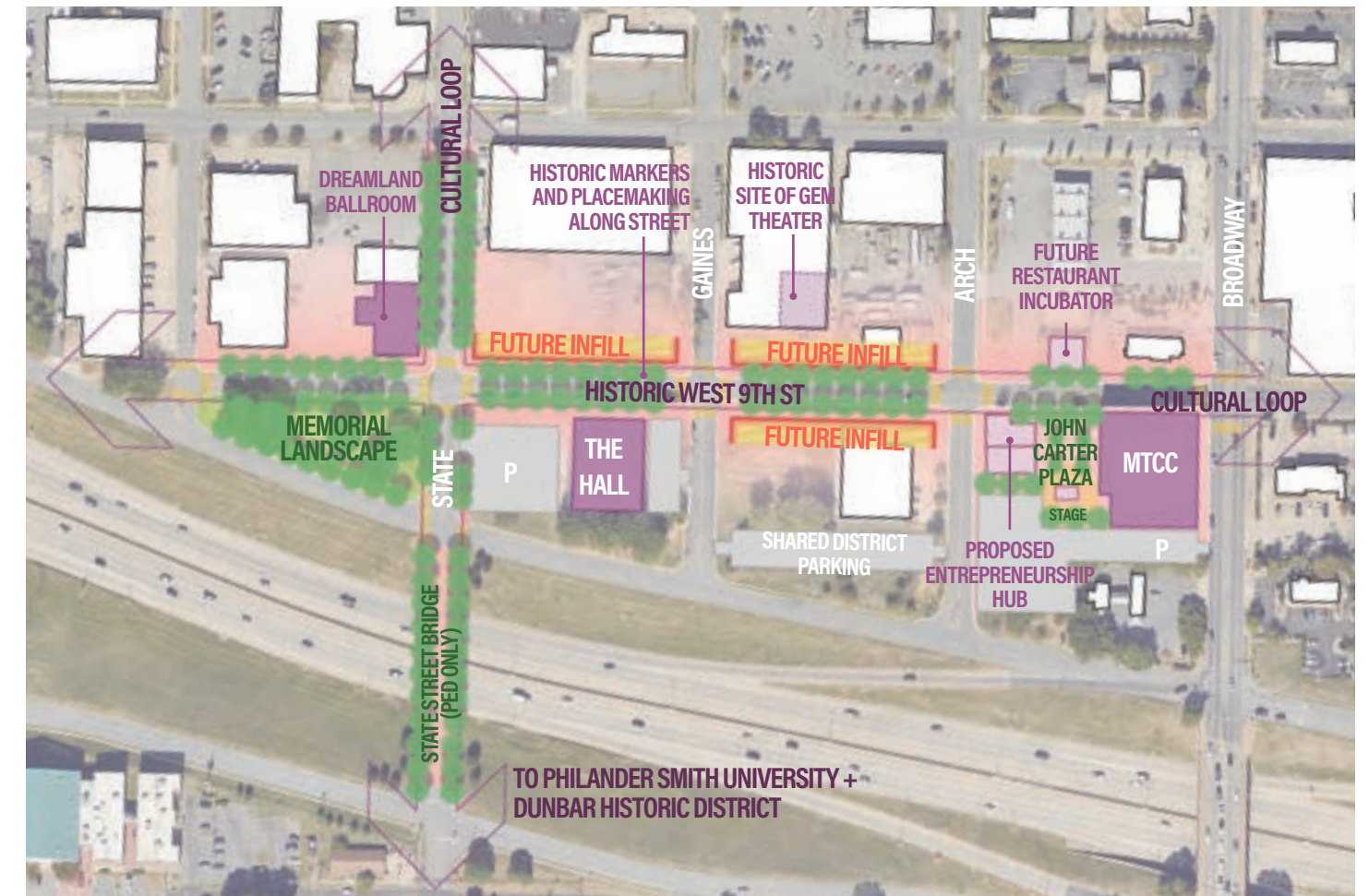

Strategy 3B

Partner with Arkansas-based higher education institutions to expand their presence in Downtown to drive innovation and activity

Lead Implementer:	City of Little Rock
Other Groups:	Downtown Partnership; Little Rock Regional Chamber; Little Rock Tech Park; Higher Education Institutions; Private Industry
Timeline:	Short-Term (1-3 Years)
Funding Sources:	No Funding Required



Although Downtown has numerous higher education assets, including Philander Smith University, UALR's Bowen School of Law, and the University of Arkansas' Clinton School of Public Service, their opportunities for large-scale expansion are limited. The City of Little Rock, Downtown Partnership, and Little Rock Regional Chamber should explore additional expansion of existing higher education institutions in Arkansas. An exploratory committee should be created to facilitate the establishment of partnerships between existing institutions and pursuing the relocation or expansion of an existing institution to Downtown. The Little Rock Tech Park is an ideal location for initial space for higher-education expansion, and their surface parking



lot on Main Street should be considered a primary site for a new higher-education facility in the future. Lastly, in addition to attracting a new higher-education institution, the City should partner with existing higher-education institutions and developers to construct dedicated student housing on city-owned land to provide affordable housing opportunities, driving vibrancy in the process.

Strategy 4A

Connect key institutions such as Mosaic Templars, Philander Smith, Dunbar Historic Neighborhood, and Central High School to lead Black History and Civil Rights walking tours

Lead Implementer:	City of Little Rock; LRCVB; Mosaic Templars Cultural Center
Other Groups:	Philander Smith Univ.; Central High Museum; Local Neighborhood Associations
Timeline:	Short Term (1-3 Years)
Funding Sources:	LRCVB; City of Little Rock General Fund; Philanthropy; Neighborhood Association financial support

Little Rock's significant Civil Rights and Black history should be celebrated to educate locals and tourists alike. The City and LRCVB should facilitate conversations between key entities such as Mosaic Templars Cultural Center, Dunbar Neighborhood Association, the Little Rock Central High School National Historic Site, and Philander Smith University to identify opportunities for quick implementation of monthly walking tours to important historic assets. These walking tours should be promoted by the City, LRCVB, the Downtown Partnership as others.



Strategy 4B Construct a Cultural Loop through streetscape enhancements, connecting historic and cultural assets while enhancing placemaking

Lead Implementer:	City of Little Rock Public Works; City of Little Rock Parks & Recreation
Other Groups:	Little Rock Parks Conservancy; Central Arkansas Library System (CALs), Private Development; Rock Region Metro, Museums
Timeline:	Phase 1 Improvements are Short Term (1-3 Years); West Ninth Street and State Street improvements are Medium Term (4-8 Years)
Funding Sources:	STBG Grants; Neighborhood Access and Equity Grant Program; USDOT Reconnecting Communities and Neighborhoods Grant; Arkansas Transportation Alternatives Program Grant; Philanthropy; Special Purpose District financing; National Endowment of the Arts Placemaking Grant

- 1 Establish a committee comprised of local historians, designers, and other stakeholders to review potential cultural loop branding.
- 2 Hire a local design firm and/or advertisement agency to establish a brand for cultural loop materials.
- 3 Install new signage, historical markers, and branding along the Arkansas River Trail between North Gaines Street and "La Petite Roche" to establish the identity of the Little Rock Cultural Loop.
- 4 Construct a Phase 1 Cultural Spine from "La Petite Roche" to MacArthur Park, improving sidewalks and constructing bike lanes. This should be done as part of Priority Streetscape Projects outlined in Loop, Stitch, and Reconnect. Rock Street and Cumberland Street should both be considered as possible routes.
- 5 Reconstruct West Ninth Street from Commerce Street to State Street with enhanced sidewalks and cultural trail branding, including educational and historical markers.
- 6 Install bike lanes, repair broken or missing sidewalks, and install Cultural Loop signage and branding along State Street between West Ninth and LaHarpe Boulevard.



Source: Birmingham Civil Rights District

Although Downtown Little Rock has the largest concentration of cultural and institutional assets in the State of Arkansas, many feel disconnected from each other even if they are not physically far apart. Creating clear, legible connections between these assets will make movement between destinations easier, reduce short distance driving trips, reducing the need for parking, and will allow placemaking to create a sense of joy in moving through the city.

A successful Cultural Loop will build off existing trails to create a unified path for pedestrians and cyclists. This includes consistent signage and artwork, consistent use of pavers, lighting, and street furniture, and clear wayfinding. Today, the Arkansas River Trail connects key assets and can easily be a starting point for branding and marketing. Extensions of the River Trail to Union Station and the Clinton Library create a single spine that connects popular destinations. The next phase could be a north-south spine linking the River Market to MacArthur Park and the AMFA. Future phases should connect MacArthur Park to the Mosaic Templars Cultural Center and West Ninth, and then connect the West Ninth corridor to the Arkansas River.

Existing Trail



The existing Arkansas River Trail should serve as a portion of the proposed cultural loop. Enhancements along the trail should include improved wayfinding and educational signage, expanded public art (such as the Indianapolis Cultural Trail), expansion of the Vogel Schwartz Sculpture Park, and trail enhancements to improve its visibility and access.

Rock Street + State Street



Rock Street and State Street's enhancements should include rebuilding the roadways with bike lanes and enhanced sidewalks to serve as strong, clear north-south conduits from surrounding neighborhoods to the River and to other points in Downtown. This should include consistent streetscape elements such as trees, lighting, furniture, and signage. Cumberland Street should be considered as an alternative to Rock Street.

Ninth Street

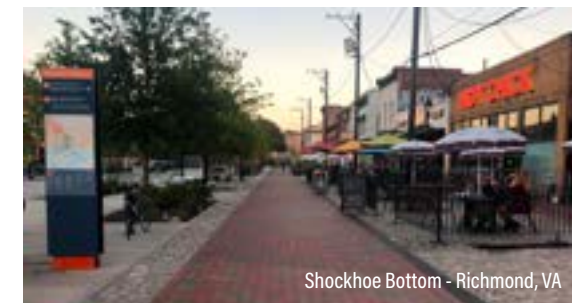

West Ninth Street's prominence as the city's Black Main Street has been lost over time, largely due to the construction of I-630. Rebuilding the street should center around creating a public realm that supports vibrancy, walkability, reinvestment, and retail growth. It should include wide sidewalks, with a design consistent with State and Rock Street to create a unified trail.

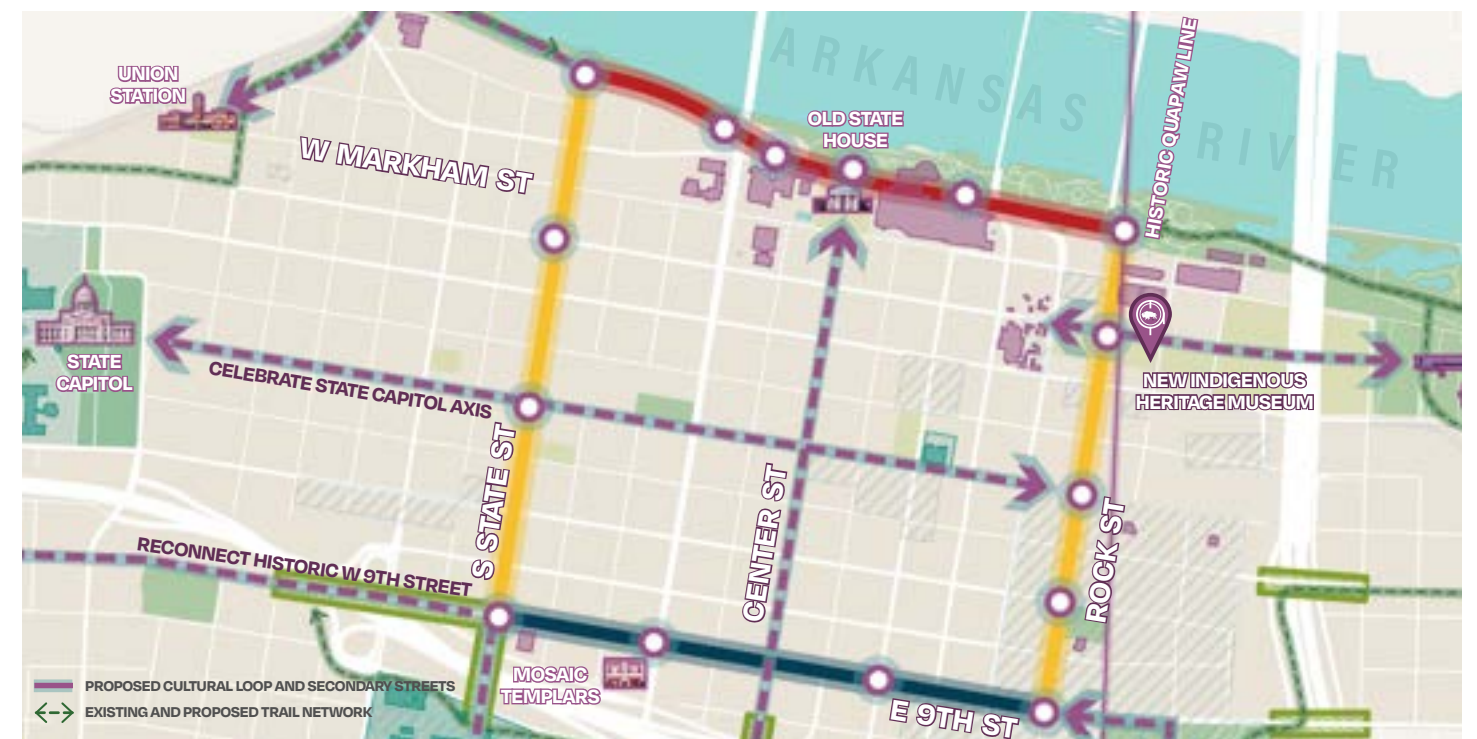

6

Appendix



Appendix



Table of Contents

Sources and Citations	209
Benchmark Studies for Downtown Little Rock.....	212
Shared Parking District Report	241
Benchmark Cities New Development and Renovations.....	251

Sources and Citations

Arkansas Business. "Venue and Image Upgrades Part of Little Rock Tourism Master Plan." 2024. <https://www.arkansasbusiness.com/article/venue-and-image-upgrades-part-of-little-rock-tourism-master-plan/>.

Arkansas Democrat Gazette. "Signs to mark Trail of Tears in Benton County." 2019. <https://www.arkansasonline.com/news/2019/oct/17/signs-to-mark-trail-of-tears-in-benton-/>.

Arkansas Heritage. "1833-1859: Capital For a New State." 2024. <https://www.arkansasheritage.com/old-state-house-museum/about/history>.

Arkansas History Commission. "The 1968 Little Rock Uprising." 2015. <https://arktimes.com/news/arkansas-reporter/2015/09/10/the-1968-little-rock-uprising>.

Arkansas State Archives. "Ninth Street in Little Rock." 2020. <https://digitalheritage.arkansas.gov/exhibits-online-african-americans/28/>.

Caldwell, Paul. "Photos of Arkansas." 2014. <https://photosofarkansas.com/2014/02/22/022114-featured-arkansas-photography-moonset-and-sunrise-over-downtown-little-rock/>.

CALS. 2024. <https://encyclopediaofarkansas.net/entries/>.

Chandler, Wil. "Rock and Role: 300 Years of La Petite Roche." 2022. <https://www.littlerocksoiree.com/rock-and-role-300-years-of-la-petite-roche/>.

City of Des Moines. "City of Des Moines Plan and Zoning Commission." 2022. <https://cms2.revize.com/revize/desmoines/P&Z%20Packet%2012.15.22.pdf>.

City of Little Rock. "Museum History." 2024. <https://www.littlerock.gov/residents/parks-and-recreation/park-facility-trail-information/macarthur-museum-of-arkansas-military-history/about/museum-history/>.

Delimont, Danita. "Visiting the Arkansas State Capitol Building." 2019. <https://www.tripsavvy.com/visiting-the-state-capitol-2211857>.

Dunn, Bob. "Little Rock City Hall." 1981. <https://commons.wikimedia.org/wiki/File:Little-Rock-City-Hall.jpg>.

Durning, Dan. "Viva Vigo's Public Art!" 2018. <https://www.eclecticatbest.com/2018/06/viva-vigos-public-art.html>.

Everson, Bart. "Downtown Little Rock." 2018. <https://www.flickr.com/photos/editor/44717071932>.

Ford, Paige A. "Mound S at Plum Bayou Mounds." 2022. <https://archeology.uark.edu/features/mound-s/>.

Govt. Printing Office. "File: US Courthouse and Post Office, Little Rock, Arkansas.jpg." <https://en.m.wikipedia.org/wiki/File:U.S.-Courthouse-and-Post-Office,-Little-Rock,-Arkansas.jpg>.

Guy, Jazz. "Kansas City Considers Doing Away with Transit Fares Citywide." 2019. <https://nextcity.org/urbanist-news/kansas-city-considers-doing-away-with-transit-fares-citywide>.

Hadley Company. "Little Rock Central High School." 1966. <https://www.wisconsinhistory.org/Records/Image/IM5002>.

Historic Arkansas Museum. "Hinderliter Grog Shop." 2024. <https://encyclopediaofarkansas.net/media/hinderliter-grog-shop-15035/>.

Lee, Hoyoung. "Bishop Arts Can Be a Model for Southern Dallas Development." 2018. <https://www.dmagazine.com/publications/d-magazine/2018/dallas-and-the-new-urbanism/bishop-arts-southern-dallas-development/>.

Library of Congress. "The History of Little Rock." 2020. <https://www.littlerockguestguide.com/post/98165/the-history-of-little-rock>.

Little Rock Convention & Visitors Bureau. "Quapaw Line Markers." 2024. <https://www.littlerock.com/directory/quapaw-line-markers/>.

Little Rock Culture Vulture. "Little Rock Look Back: THE EAGLE has landed (LR's first steamboat)." 2018. <https://lrculturevulture.com/2018/03/16/little-rock-look-back-the-eagle-has-landed-lrs-first-steamboat/>.

MAA Greene Apartments. 2024. <https://www.forrent.com/sc/greenville/maa-greene/tl9ffxc>.

Phillips, Gene. "10 Things to Eat and Do on Atlanta's BeltLine." 2022. <https://www.southernliving.com/travel/georgia/atlanta-beltline>.

Rosales + Partners. "Falls Park on the Reedy." 2015. <https://www.architectmagazine.com/project-gallery/falls-park-on-the-reedy>.

Rundell Ernstberger Associates. "Indianapolis Cultural Trail, A Legacy of Gene and Marilyn Glick." 2024. <https://www.reasite.com/projects/indianapolis-cultural-trail>.

Saunders, Earl Jr. "UA Little Rock Center for Arkansas History and Culture." 1961. <https://ualrexhibits.org/mappingblog/2019/08/05/town-and-country-westward-sprawl-in-little-rock-part-ii/>.

SB Friedman Development Advisors, LLC. "Little Rock Downtown Plan, Benchmark Cities - New Development and Renovations." 2023.

Steele, William. "Fort Smith." 2013. <https://jaysteeleblog.wordpress.com/2013/03/08/fort-smith/>.

Tichnor Brothers. "Museum of Fine Arts, MacArthur Park, Little Rock, Ark." 1930. [https://commons.wikimedia.org/wiki/File:Museum-of-Fine-Arts,-MacArthur-Park,-Little-Rock-Ark-\(65472\).jpg](https://commons.wikimedia.org/wiki/File:Museum-of-Fine-Arts,-MacArthur-Park,-Little-Rock-Ark-(65472).jpg).

T-Mobile. "T-Mobile Announces \$163 Million in Completed Network Upgrades for Arkansas." 2024. <https://www.t-mobile.com/news/network/t-mobile-announces-163-million-in-completed-network-upgrades-for-arkansas>.

Trip Advisor. "Little Rock Photo: Amphitheater at the Park Along the River." 2015. <https://www.tripadvisor.com/LocationPhotoDirectLink-g60766-i140393485-Little-Rock-Arkansas.html>.

USGS. "National Land Cover Database." 2018. <https://www.usgs.gov/centers/eros/science/national-land-cover-database>.

US Census Bureau. "Commuting Datasets." 2021. <https://www.census.gov/topics/employment/commuting/data/datasets.html>.

Walk Score. "Data Services." 2024. <https://www.walkscore.com/professional/research.php>.



BENCHMARK STUDIES

For Downtown Little Rock

SASAKI

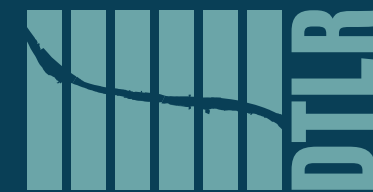

Overview

Introduction	1
Little Rock	3
Benchmark Cities	5
Chattanooga	7
Greenville	9
Richmond	11
Additional Cities	13
Benchmark Downtown Plans	17
Birmingham	19
Raleigh	21
Des Moines	23
Sources	25



01

Introduction

Downtown Little Rock is unique in its geographic location, its status as a state capitol, and its position as the economic heart of a state. However, there are several other cities that share many of Little Rock's characteristics that can serve as benchmarks to better understand how those downtowns operate within their metropolitan area, and how they compare with Little Rock in terms of population growth, housing, economic trends, and employment. In order to understand how Little Rock compares, three benchmark cities have been identified: Chattanooga, TN, Greenville, SC and Richmond, VA. Benchmark downtown plans from the following three cities have also been identified: Raleigh, NC, Birmingham, AL and Des Moines, IA. These benchmarks can serve as a guide for understanding how other cities are leveraging an aligned vision to achieve economic growth and success. Each of these cities has taken a unique approach in terms of developing their downtowns for the twenty-first century, and all can provide lessons for things Little Rock should consider looking into the future.



Little Rock

Arkansas



CITY DEMOGRAPHICS

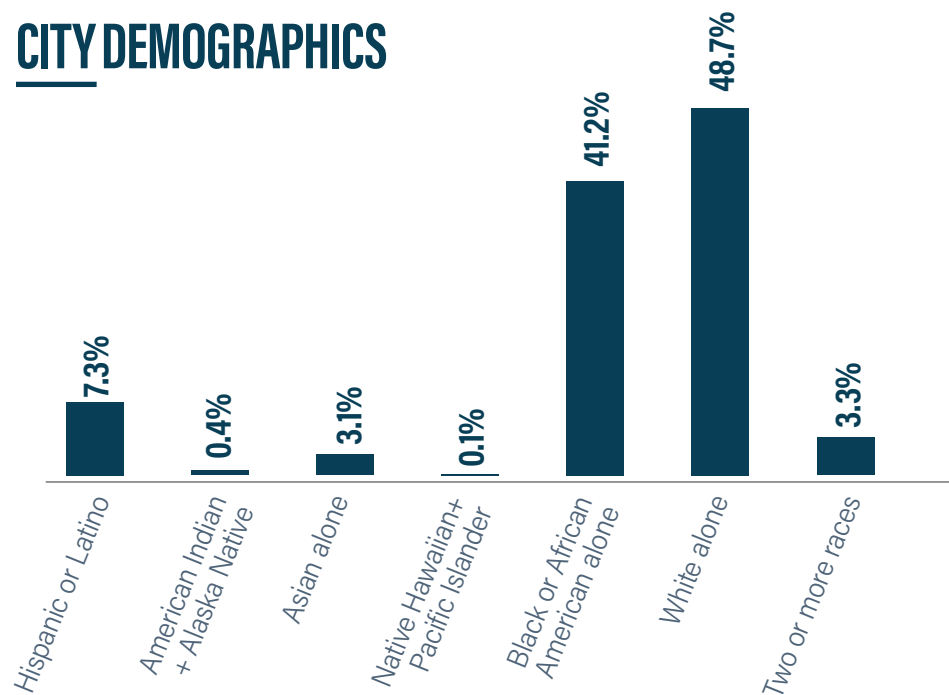

757,945 Metro Population

202,851 City Population

4,395 Downtown Population

1,758 Downtown Pop. Density
People/sq. mi



56.8% Population with Bachelor's Degree or higher

30.4% Population Aged 20-34

53.9% Black Indigenous People Of Color Population



\$56,928 Median Household Income (15.6% poverty rate)

\$189,500 Median Home Value (\$940 Median Rent)



Historic Downtown Little Rock 1958, Photo courtesy of the Butler Center for Arkansas Studies, Central Arkansas Library System.

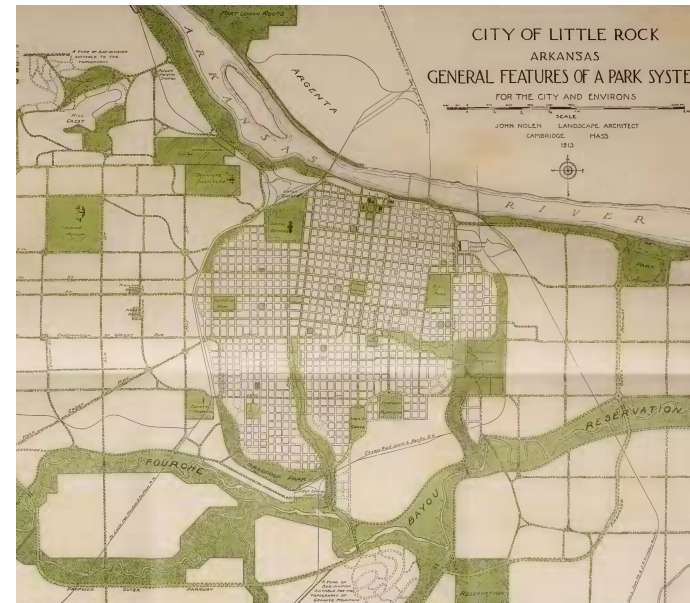

Report on a Park System for Little Rock Arkansas, John Nolen, 1913.

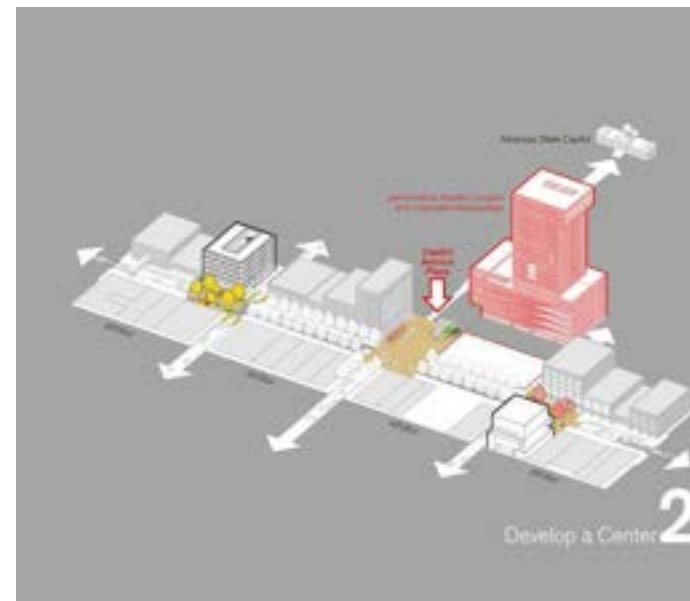

The Creative Corridor: A Main Street Revitalization for Little Rock, 2014, University of Ark. Community Design Center and Marlon Blackwell Architect.

CITY HISTORY

- Little Rock is the ancestral homeland of the Caddo, Osage, and Quapaw peoples. The city sits at the crossroads of the land and water path of the Trail of Tears.
- Little Rock was first settled by Europeans in 1812, serving as a trading post at a significant crossing of the Arkansas River. By 1821, the city was named the capitol of the Arkansas Territory, which became a state in 1836.
- Little Rock was the site of a Civil War battle and occupation by Union troops in 1863.
- The city grew substantially after the Civil War, with the downtown becoming the epicenter of commerce in Central Arkansas by the early 1900's.
- Downtown Little Rock fell into decline beginning in the 1960s due to suburban sprawl and White Flight from the core of the city.
- Numerous revitalization efforts have occurred since, including the establishment of the River Market in 1996, to reinvest in the heart of the city.

CITY ECONOMY

Downtown Little Rock is the largest employment district within Central Arkansas, with over 40,000 workers. The area has a large number of governmental jobs due to the State Capitol and associated state offices, the City of Little Rock, Pulaski County, and the Little Rock School District. The area also has a large financial sector, including Stephens Inc., Simmons Bank and Arvest Bank. Other notable industries within downtown include healthcare, legal, leisure, hospitality, and education.

DOWNTOWN PLANNING

Downtown Little Rock has never conducted a master planning effort. However, there have been numerous important guiding plans that can serve as a foundation.

1913 —The famous landscape architect John Nolen conducted park planning for the city, which served as the first notable downtown planning effort. Although the city did not implement many of the recommendations, elements of the plan can still be seen in physical form today.

1982 —The Downtown Little Rock Development Plan was the first concerted public-private effort to redevelop the downtown riverfront and East Markham Warehouse District.

2001 —Little Rock Parks System Master Plan

2012 —The Creative Corridor Plan for Main Street

2023 —The Tourism Master Plan.



Benchmark Cities

Richmond, Virginia, Chattanooga, Tennessee, and Greenville, South Carolina are all mid-sized Southern cities with diversified populations and economies that share many characteristics with Little Rock. For each, investment and revitalization of their downtown has been key to their success in recent decades.

Richmond, Virginia is a sister Southern State Capitol that shares many demographic features with Little Rock and also enjoys its location at the center of the state along a major river. Chattanooga, Tennessee is another river city that is similar in size, both as a city and as a metro area, to Little Rock. Both are uniquely positioned with incredible access to outdoor recreation. Greenville, South Carolina shares the least in common with Little Rock of the other benchmark cities, but is also a sizable Southern city and metro area that is situated near outdoor recreation and along a downtown river. Greenville leveraged open space and recreation through public-private partnership to attract tourism, enhance quality of life, and attract major manufacturers and corporate offices.



Chattanooga

Tennessee



CITY DEMOGRAPHICS

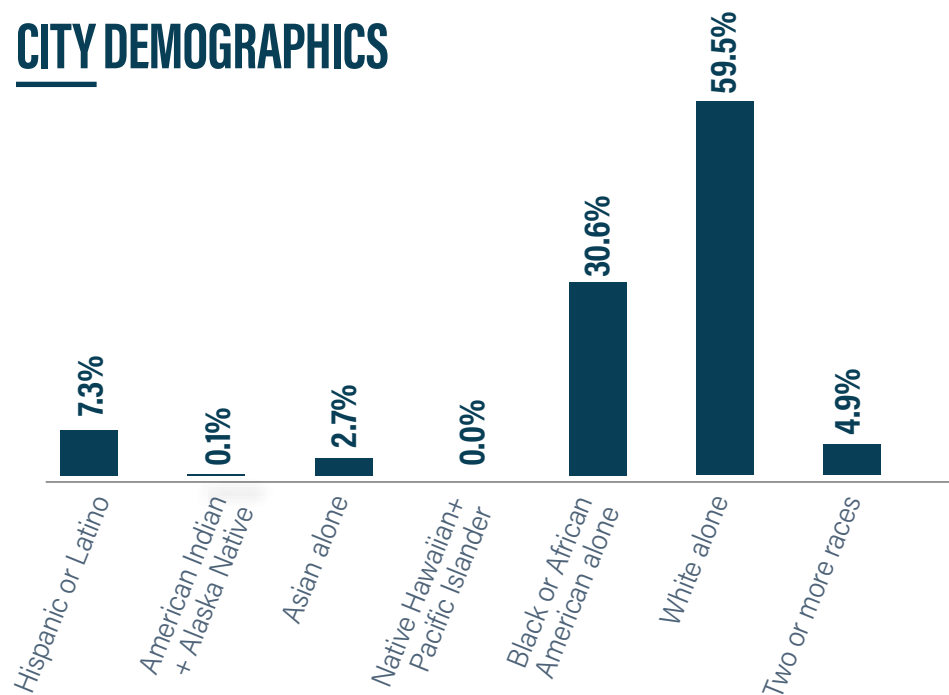

575,000 Metro Population

184,000 City Population

3,745 Downtown Population

4,161 Downtown Pop. Density
People/sq. mi



53.5% Population with Bachelor's Degree or higher

28.0% Population Aged 20-34

28.3% Black Indigenous People Of Color Population



\$50,437 Median Household Income (17.6% poverty rate)

\$184,086 Median Home Value (\$958 Median Rent)



Chattanooga, TN, author Albert Ruger 1871.

CITY HISTORY

Chattanooga sits along the Tennessee River adjacent to the Georgia border. The fertile land was home to the Cherokee People until they were forcibly removed from the city along the Trail of Tears. Europeans founded the city in 1838. It is a site of multiple Civil War battles, including Chickamauga and the Battle for Chattanooga.

The railroad and river transformed the city into an industrial hub around the turn of the century. This industrialization also resulted in Chattanooga becoming America's most polluted city in 1970. During the Civil Rights Movement, Chattanooga was home to peaceful sit-in protests that ultimately resulted in desegregation of downtown businesses. Today, the city has gained national attention for its downtown redevelopment, entrepreneurship, and outdoor adventure culture.

CITY ECONOMY

3 MILLION VISITORS
In 2022



\$70K
In Visitor Tax Revenue



\$ 3.2M
Spent by visitors

Chattanooga's low cost of living and its city-wide gigabit broadband network that is 200 times faster than the national average has made it a hub for startups. The American Reinvestment and Recovery Act funded the \$110M fiber optic network called The Gig. The city's Innovation District that houses 671 startup businesses encourages the startup scene.

The internet infrastructure has also attracted projects from global companies like Volkswagen, Amazon and Google. Chattanooga is now home to major corporations such as Shaw Industries, Lodge Manufacturing, and CBL properties all contributing to a \$43.9 billion economy.

DOWNTOWN PLANNING

1990s-2000s — Major Downtown Riverfront District projects built: The Tennessee Aquarium, Tennessee Riverwalk, AT&T Field, and the 21st Century Waterfront Park.

2002 — A downtown plan for the city was completed in 2002 by Dover & Kohl and Hargreaves Associates.

2015 — Chattanooga Design Studio created as a public-private partnership to better plan projects for downtown and surrounding areas.

2018 — Design of The Bend, a new 120 acre mixed-use project along the Tennessee River, began.

2022 — ONERiverfront Plan created in partnership with the River City Company, a non-profit economic development engine for Downtown Chattanooga.

2023 — City's Housing Action Plan created to address affordability and home ownership.

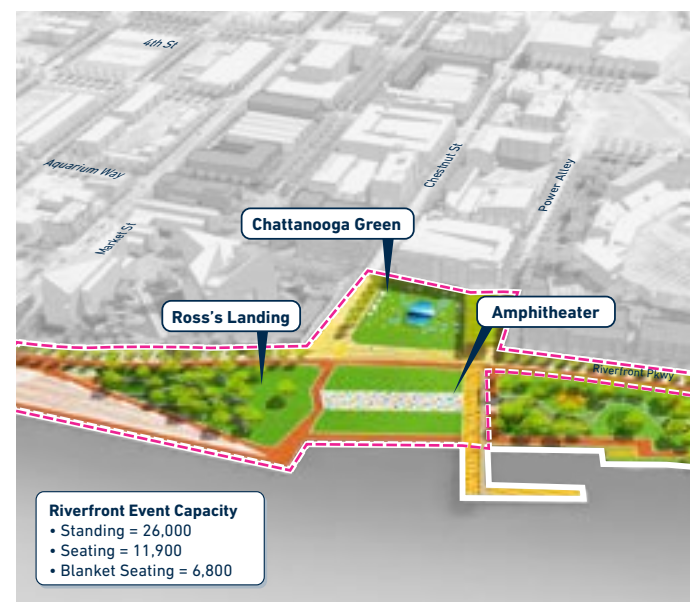

ONERiverfront Plan 2022.

Greenville

South Carolina



CITY DEMOGRAPHICS

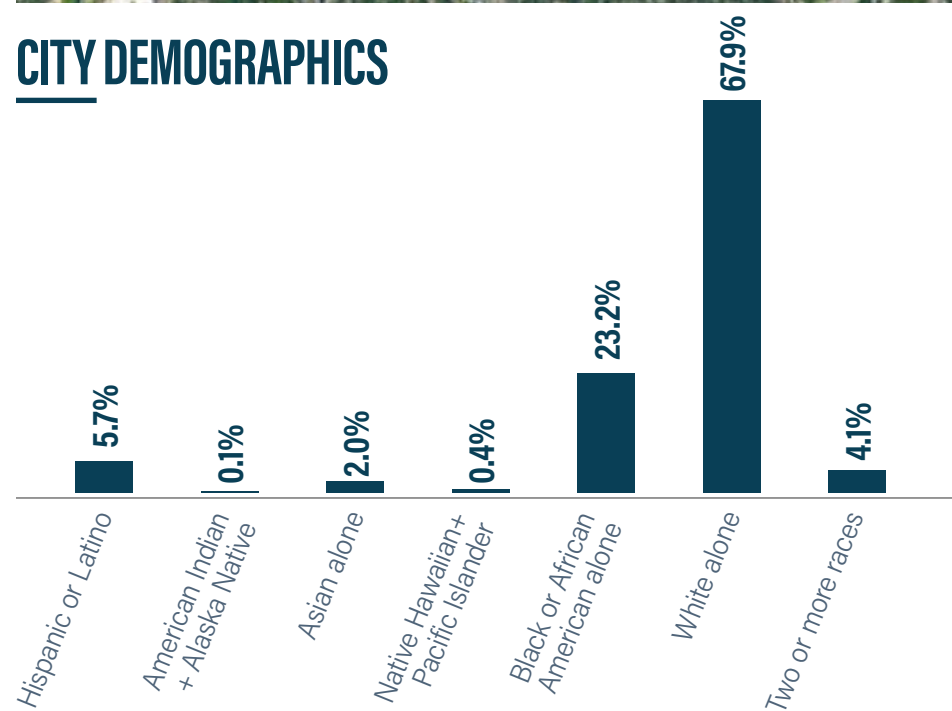

958,900 Metro Population

72,300 City Population

7,141 Downtown Population

4,760 Downtown Pop. Density
People/sq. mi



61.8% Population with Bachelor's Degree or higher

27.2% Population Aged 20-34

22.7% Black Indigenous People Of Color Population



\$60,388 Median Household Income (13.9% poverty rate)

\$349,300 Median Home Value (\$1,078 Median Rent)



Greenville District, SC Robert Mills Map 1825.

CITY HISTORY

The city sits on former hunting land of the Cherokee people who utilized the live-giving falls of the Reedy River. In 1777, Europeans forcibly removed the Cherokee and built a trading post and mill along the falls. Industries including ironworks, and mills for cotton, grist, corn, and gingham clustered around the river and used the water power.

Furman University moved from Edgefield to the city in 1851, bringing students and faculty. In WWII, a new Greenville Army Air Base further increased the town population. Post-war the city grew and expanded to the suburbs, leaving downtown vacant and the river polluted by industry. The Total Development Campaign of 1966 encouraged retailers to "slip cover" old buildings with aluminum to modernize downtown, but that was ineffective. New streetscapes of the 1980s paired with public-private partnerships finally helped turn the tide on downtown growth patterns. In the late 1990s and early 2000s, the city re-embraced the Falls on the Reedy by making it a city-center park.

CITY ECONOMY

7 MILLION VISITORS
In 2022

\$14.3M
From Accommodations tax revenue

\$28.6M
From Hospitality Tax

\$42.9M
In Visitor Tax Revenue

\$1.5B
Spent in hotels, shops, + restaurants

Greenville is a strong pro-business city. It has one of the lowest tax rates in the nation (5%) and no state taxes on property, inventory, sales on equipment, industrial power or materials for finished products. This has helped attract major businesses like Michelin North America, General Electric, Verizon, Lockheed Martin, and Proterra.

Tax Increment Financing (TIF) has been downtown Greenville's most successful financing tool. TIF funds heavily contributed to the cost of construction of the Peace Center development, many streetscape projects, parking structures, and infrastructure improvements, all of which helped revitalize downtown. Downtown now includes a Central Business Tax Increment District, West End Tax Increment District, and Viola Street Tax Increment District. Revenue from these districts has progressively increased since their creation in the 1990s.



Falls on The Reedy Park, Downtown Greenville.

DOWNTOWN PLANNING

- 1968** — First Downtown Plan aimed to revive the struggling downtown.
- 1979** — Streetscapes Plan narrowed Main Street added light fixtures, widened sidewalks, etc.
- 1982-1991** — Greenville Commons and the Peace Center for the Performing arts built on opposing ends of Main Street through private-public partnerships. Projects catalyzed downtown development.
- 1987** — Downtown Development Strategy highlighted the importance of restoring the Reedy River.
- 2004** — Falls Park on the Reedy opened. The \$13M park helped spur over \$100M in private investment within only two years.
- 2008** — Sasaki created a Downtown Master Plan providing a conceptual framework with five key anchor areas surrounding Main Street.

Richmond

Virginia

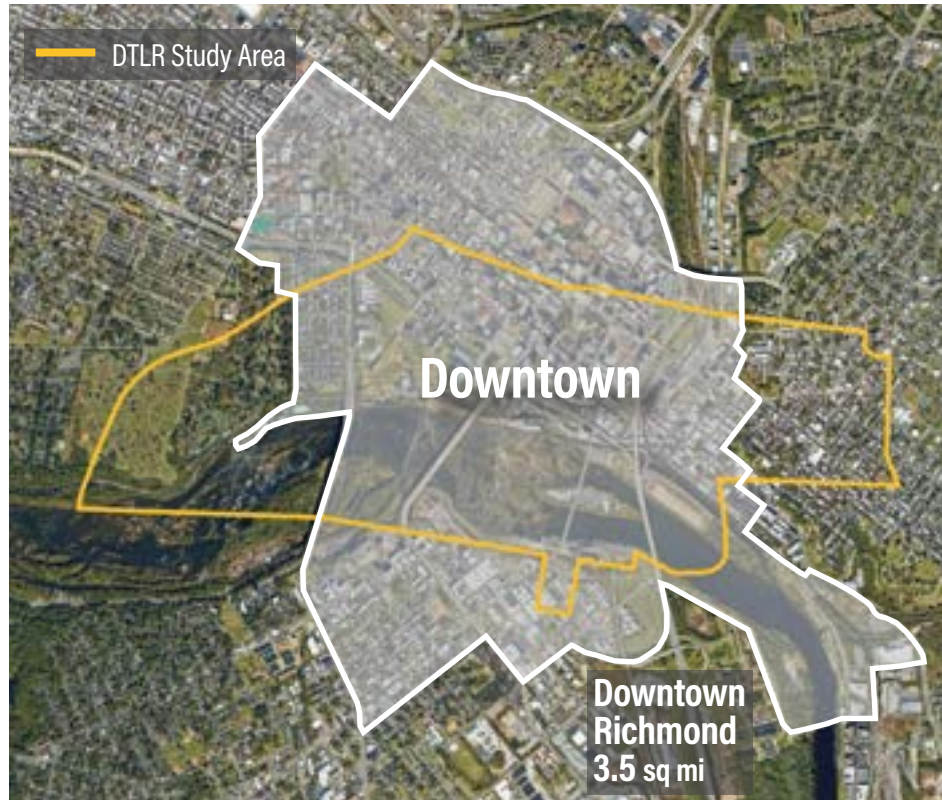

CITY DEMOGRAPHICS

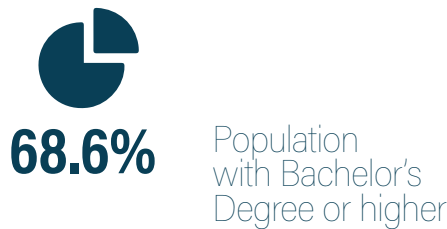
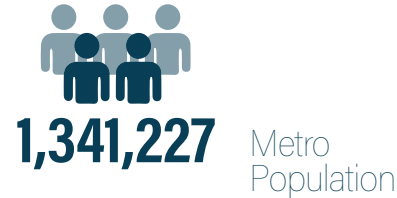
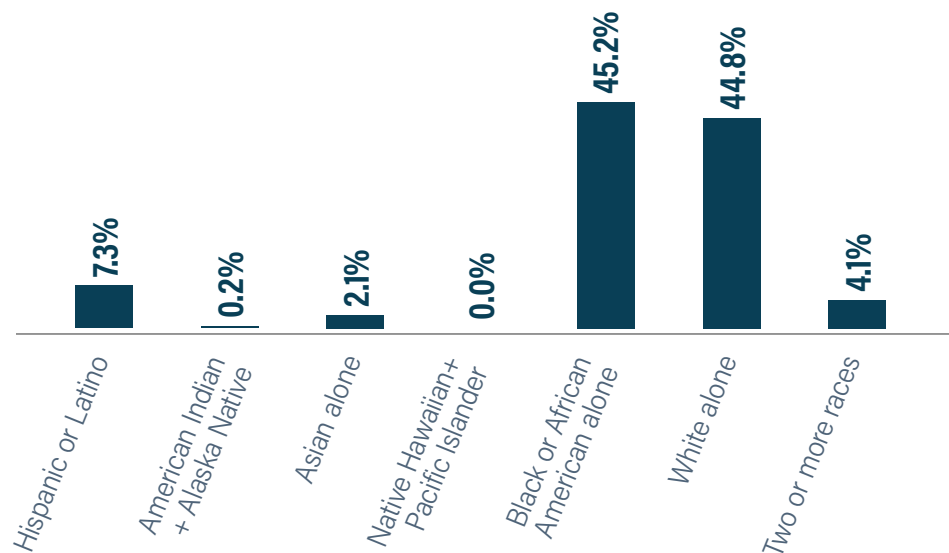

Richmond, VA 1863, by Robert Knox Sneden, Virginia Historical Society.

CITY HISTORY

Located at the Falls of the James River, the land that is now Richmond has long been a political, military, and economic hub first to Native Americans and later to Europeans. It was the Powhatan tribe capital until the native peoples were forcibly relocated. The site then became Virginia's capital under colonial rule.

The James River formerly divided Richmond into two cities: Manchester and Richmond. In 1910, the cities merged to allow for improved movement of goods along the river. An extensive railroad hub strengthened trade. During the Civil War, Richmond functioned as the city, state, and Confederate capital which led to an influx of troops and output of war provisions. Twenty-five percent of the city was burned in the war. During WWII, the city became the fastest growing industrial city in the US. In the 1960s, the downtown drastically declined after highways I-95 and I-64 were built through it. Planning efforts in the early 2000s slowly revived downtown.

4.9 MILLION VISITORS In 2022

22,312
Jobs Supported Through Tourism

\$1.2B
Spent by visitors

\$113M
In Local Tax Revenue

\$217M
Spent in hotels stays and occupancy

CITY ECONOMY

Today, primary industries include finance, biotechnology, medicine, knowledge-based services, manufacturing, and transportation industries. In 2019, the city was ranked nationally in the Metro Rankings Report as 4th in economic growth potential for mid-sized cities, second in corporate leadership, and seventh in attracting millennials.

Fiscal Year 2022 brought \$552 million in capital investment. Richmond's Enterprise Zone Program and CARE Program support economic growth of small local businesses through incentives including: Real Estate Tax Abatements, Brownfields Rebates, Employment Assistance Grants, Loan Fee Rebates, and Business Relocation Rebates.



Richmond 300 Plan, Cap Bridge to Reconnect the City.

DOWNTOWN PLANNING

1946 —First city-wide master plan created by Richmond led to mass displacement of African American businesses and homes downtown.

1980 —Greater Richmond Convention Center and 6th Street Market Place built to revive downtown.

1980-2005 — Adaptive reuse of tobacco warehouses and factories along Tobacco Row revived the district.

2009 — Downtown Plan created a unique plan for the six downtown areas to improve livability and connectivity.

2020 — Richmond 300 Plan: A Guide for Growth was created and centered on equity to guide downtown development. The plan proposed rewriting the Zoning Ordinance.

2022 —A Strategic Plan for Equitable Economic Development created to build a more equitable economy downtown.

Additional Cities

OKLAHOMA CITY, OK

Beginning in the 1960s, Downtown Oklahoma City underwent a major urban renewal initiative known as the Pei Plan, which resulted in the large-scale demolition of numerous blocks and over 500 buildings of the historic fabric of downtown. Although much of the infrastructure was installed, much of the private development housing failed to materialize due to the plan's top-down nature and over-dependence on federal funds that dried up.

After the Oklahoma City bombing of 1995, the city desired a redevelopment strategy to bring energy and vibrancy to the moribund downtown, which Mayor Ron Norick believed was key to business retention and attraction. The Bricktown redevelopment began in the mid-1990s at the historic crossroads of commerce in the city. The plan utilized a series of tax incentives and a five-year sales tax to revitalize the historic warehouse buildings.

The resulting MAPS (Metropolitan Area Projects) plan was a \$350 million public works and redevelopment project which resulted in the construction of a new Triple-A

ballpark, renovations to existing performing arts facilities, transit enhancements, and the construction of a new mile-long canal, all of which laid groundwork for subsequent redevelopment.

Oklahoma City has extended the sales tax increase through multiple iterations, including: A \$700 million initiative geared towards schools and children's programs; a \$777 million initiative geared towards quality of life enhancements such as new parks, a streetcar, public realm enhancements; and a \$978 million initiative geared towards citywide neighborhood improvements. As of 2019, the city estimated that MAPS has generated \$7 billion in investment for the city over 20 years.



Oklahoma City Bricktown entertainment district.

CHARLESTON, SC

Downtown Charleston's historic fabric is one of the United States' most walkable and historic cities. The Charleston Downtown Plan: Achieving Balance Through Strategic Growth was the 1999 Downtown Master Plan. The Plan created a series of development tools to help the city manage its successful revitalization, while maintaining a high quality of life for its citizens. The plan laid a vision for guiding and directing growth, including visions for land use, streets, and redevelopment. The plan proposed a new organizational structure with the Charleston Downtown Partnership at the center of downtown development, connecting community, city, and business.

Central to Charleston's success and vision was a strong emphasis on urban design by then-Mayor Joe Riley. As

recommended in the 1999 Downtown Master Plan, the Charleston Civic Design Center was created in 2001 to elevate the dialogue of urban design within Charleston. The Charleston Civic Design Center serves as a public engagement venue, design workshop and charrette studio, community event space, project gallery and information center for the general public about urban design and planning matters. This public-private partnership studio serves as a conduit for development and design ideas within the city and helps inform and guide downtown development, ensuring high-quality design outcomes.

A vision for the lower peninsula

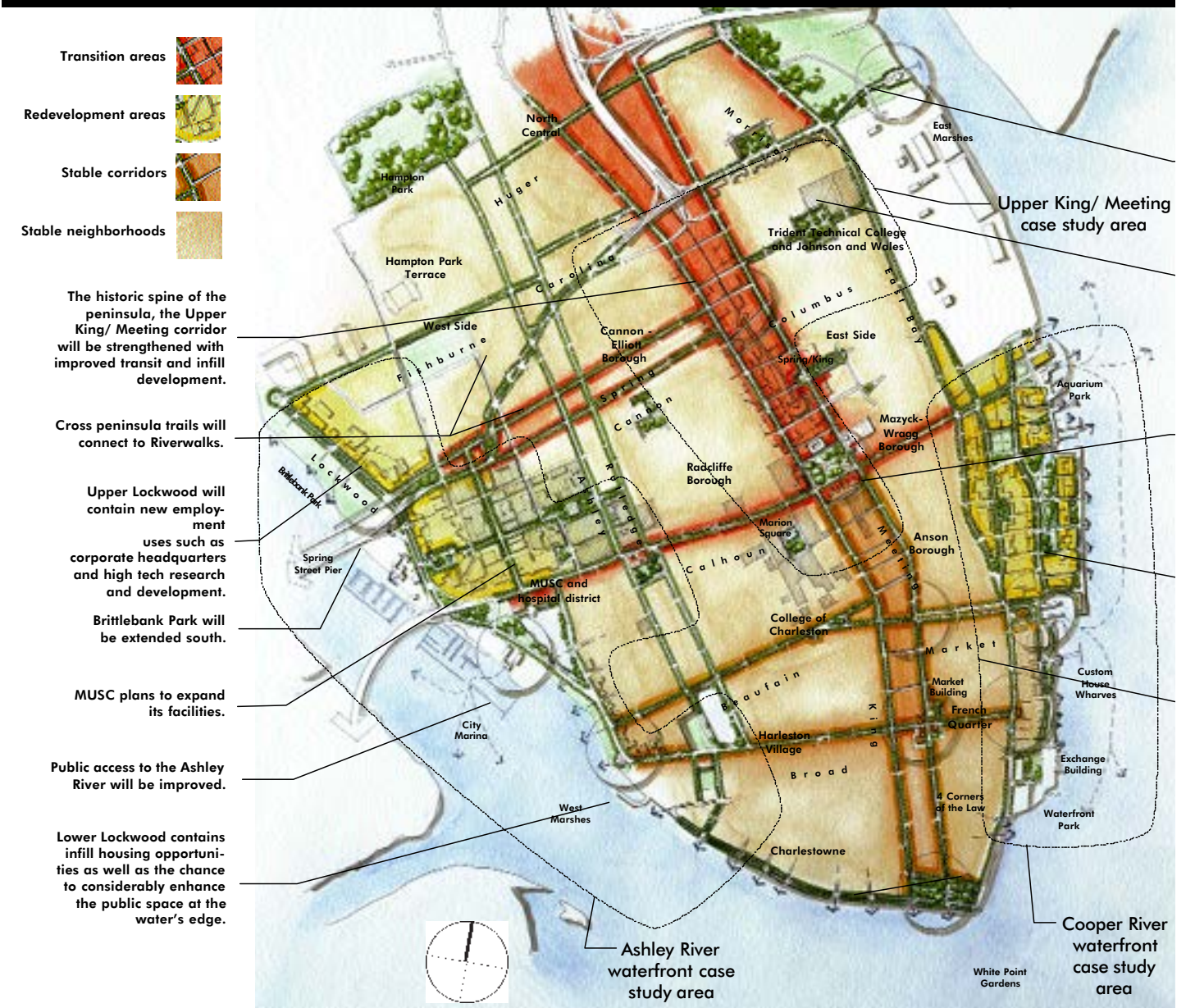

Charleston Downtown Plan 1999.

Development By the Numbers



Downtown
Population



Downtown
Density
People/sq. mi.



Retail Downtown
(SF)



Leasable Office
Space (SF)



Multifamily
Rental Units



Hotel Rooms

LITTLE ROCK

4,395

1,758

New Development (2010-2023)

49,500

253,800

245

463

Renovations (2010-2023)

52,700

421,200

183

820

TOTAL

102,200

675,000

428

1283

CHATTANOOGA

3,745

4,161

New Development (2010-2023)

114,900

165,900

988

535

Renovations (2010-2023)

85,900

474,500

69

343

TOTAL

200,800

640,400

1,057

878

GREENVILLE

7,141

4,760

New Development (2010-2023)

309,500

947,000

2,380

1,558

Renovations (2010-2023)

116,200

804,900

197

200

TOTAL

425,700

1,751,900

2,577

1,758

RICHMOND

27,565

7,875

New Development (2010-2023)

124,900

2,108,900

8,178

627

Renovations (2010-2023)

173,800

1,935,100

1,423

1,425

TOTAL

298,700

4,044,000

9,601

2,052

Benchmark Downtown Plans

Numerous cities have leveraged downtown plans as a way to create a unified vision to guide development, philanthropy, and policy. Downtown Raleigh, North Carolina, Downtown Birmingham, Alabama, and Downtown Des Moines, Iowa are three mid-sized cities (including two state capitals) that have recently completed downtown master planning efforts to catalyze new development. Although each took different approaches in their key frameworks and catalytic projects, they can serve as a guide for the success that can germinate from the creation of a planning effort.



Birmingham

Alabama



CITY DEMOGRAPHICS

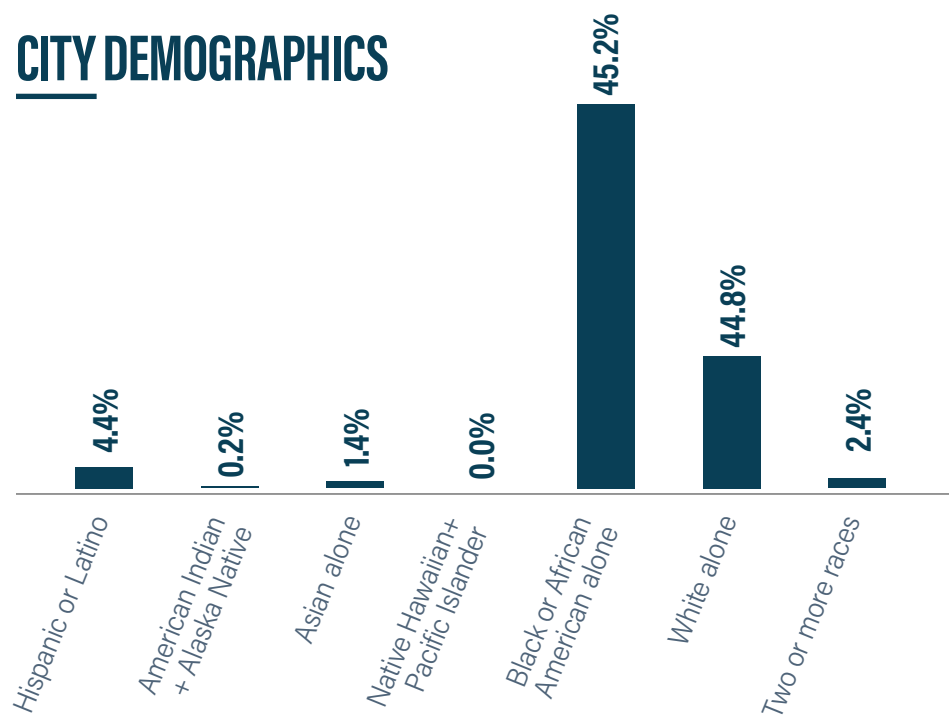

1,116,857 Metro Population

181,057 City Population

12,000 Downtown Population

4,553 Downtown Pop. Density
People/sq. mi



\$550M In Development Projects in 2021

419 Retailers Downtown

18M SF of Leasable Office Space



6,622 Multifamily Apartment Units

1,605 Units Under Construction



City Center Master Plan, Civil Rights District active park edge improvement.

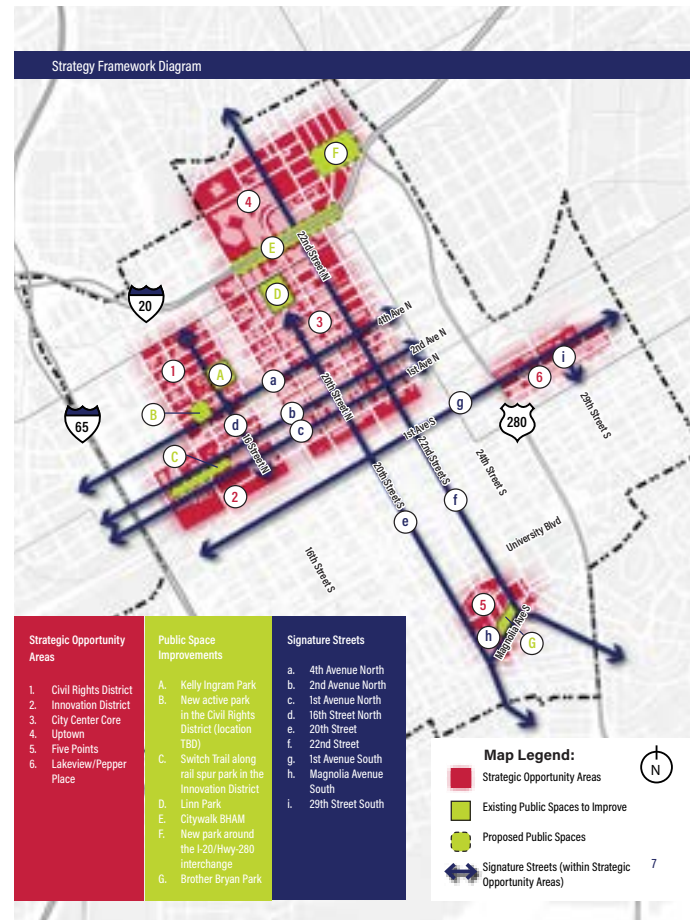

City Center Master Plan Strategic Framework 2020.

PLAN FRAMEWORK

Year of Plan: 2020

SIX GUIDING PRINCIPLES

- Equity is essential
- Focus investments into key nodes to create compact mass
- Build for people
- Respect, maintain, and celebrate Birmingham's living history
- Jobs drive growth and housing drives vibrancy
- Mobility is much more than moving cars

STRATEGIES FOR SUCCESS

1. Public Realm and Streetscape Strategies
2. Mobility and Parking Strategies
3. Strategic Opportunity Areas

IMPLEMENTATION

SPACES

- Six strategic opportunity areas: Civil Rights District, Innovation District, City Center Core, Uptown, Five Points South, Lakeview
- Nine Signature Streets
- Seven Public Space Improvement Areas

APPROACH

- Operations and Maintenance Strategies
- Minimum Development Program
- TIF Analysis Based on Expected Development Activity
- Priority Initiatives
- Implementation Matrix

PROGRESS POINTS

City Center now operates as a Business Improvement District (BID). The property owners are represented by the City Center District Management Corporation who contracts with REV Birmingham, an economic development non-profit that manages the BID, oversees public space improvements, and runs a safety ambassadors program. The BID funds these improvements and capital projects.

2022-2023 Achievements

- 44 new storefront openings downtown.
- Redesign of 20th Street North, downtown's main street, including improved seating, native plant design, dedicated bike lanes, and flex lanes.
- Launch of new brand website for downtown.

Raleigh

North Carolina



CITY DEMOGRAPHICS

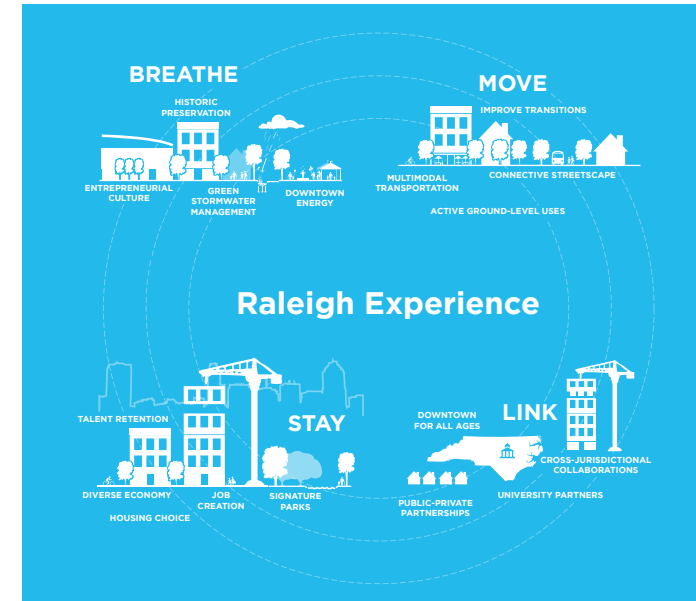
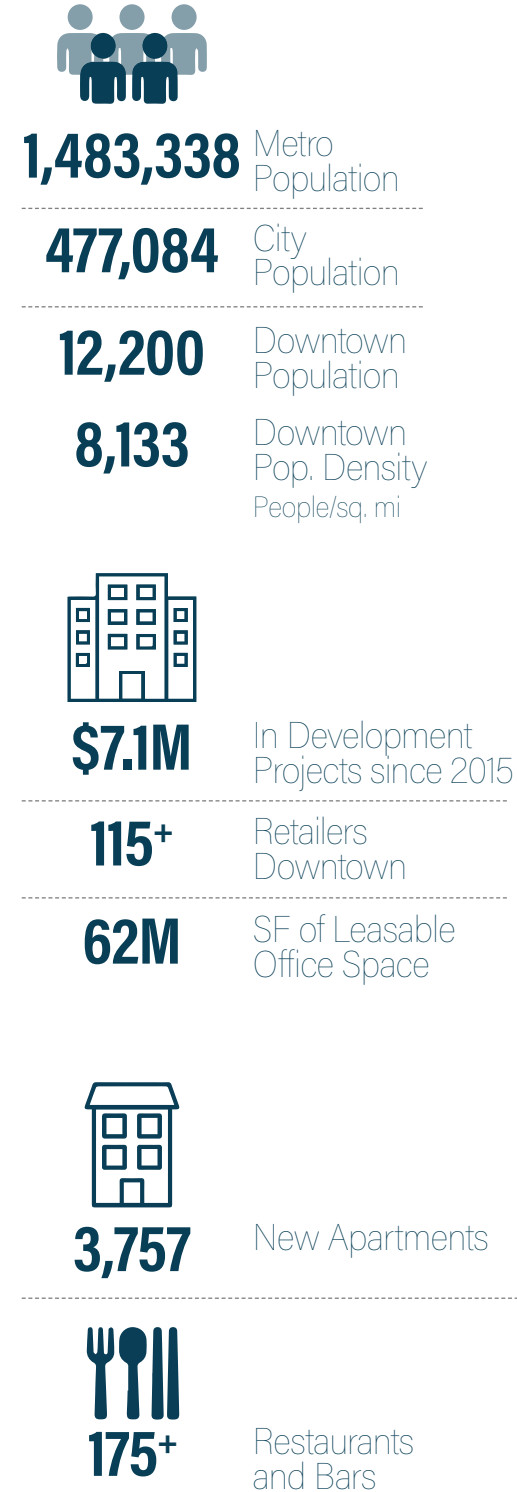
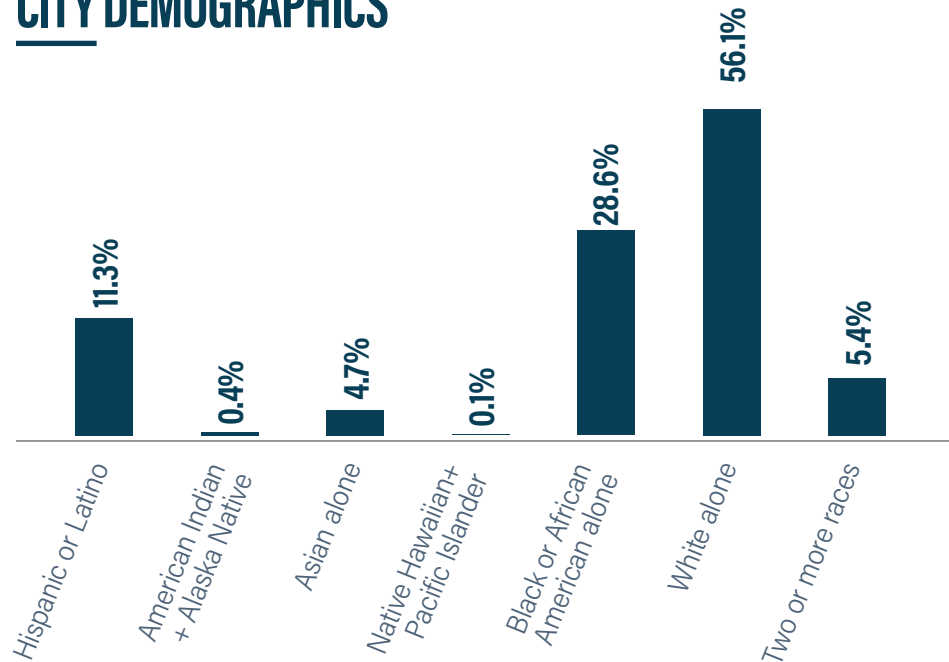

Downtown Raleigh Master Plan 2015, framework themes.



Moore Square designed by Sasaki, opening day event.

PLAN FRAMEWORK

Year of Plan: 2015

FOUR FRAMEWORK THEMES

- Breathe
- Stay
- Move
- Link

FIVE CATALYTIC PROJECT AREAS

- Glenwood Green
- North End
- Nash Square/Union Station
- Moore Square/City Market
- Gateway Center

IMPLEMENTATION

FINANCING + BUILDING PLAN

The plan implementation focuses on three key areas/strategies and gives specific actions regarding funding, governance, roles and responsibilities, and tools to recruit key uses to downtown. The three include:

- Activating the Warehouse District around a revitalized Nash Square
- Developing a framework for building out the Fayetteville District at Gateway Center
- Strengthening downtown Raleigh's retail environment

PROGRESS POINTS

- 2016** — Skyhouse apartment opened next to Moore Square.
- 2018** — New Raleigh Union Station for Amtrak opened.
- 2019** — Moore Square renovation completed under Sasaki design plan.
- 2019** — Master Plan for Dorothea Dix Property completed.
- 2022** — Deveraux Meadows Park Concept Design completed and renamed to Smoky Hollow Park as part of North Glenwood Smoky Hollow District.
- 2022** — Pendo moved its 11-story headquarters to Nash Square/Union Station catalytic area.

Des Moines

Iowa



CITY DEMOGRAPHICS

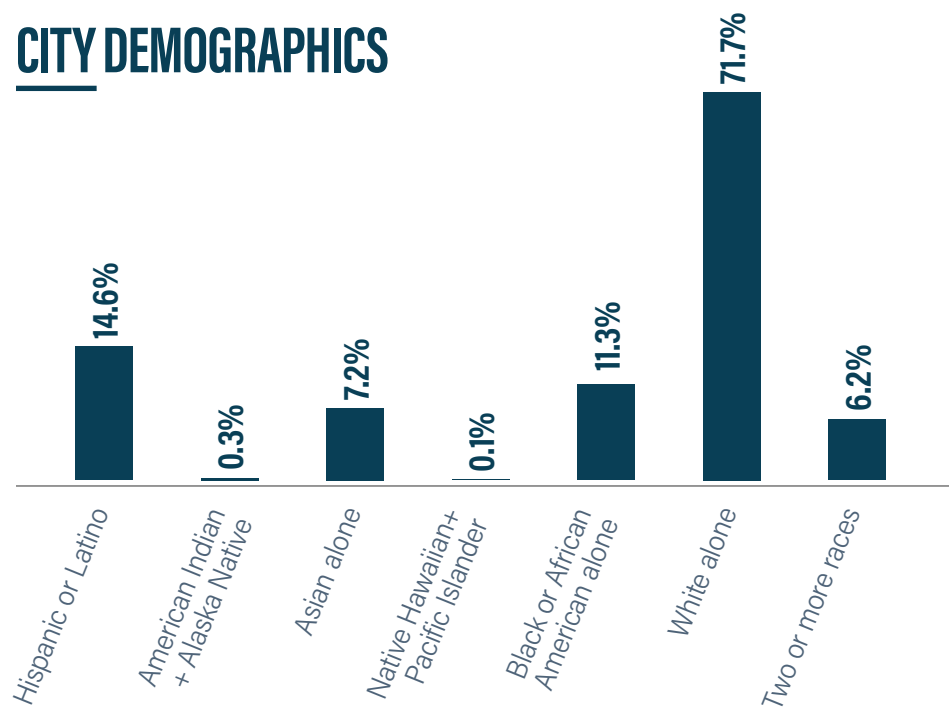

729,053 Metro Population

213,545 City Population

8,371 Downtown Population

3,960 Downtown Pop. Density
People/sq. mi



\$3B In Development Projects since 2013

\$160.5M In Hotel Development

\$1.07B In Commercial Development



\$267.6M In Residential Development



\$92M In Civic Projects



Strategy graphic, Downtown DSM: Future Forward Plan 2022.

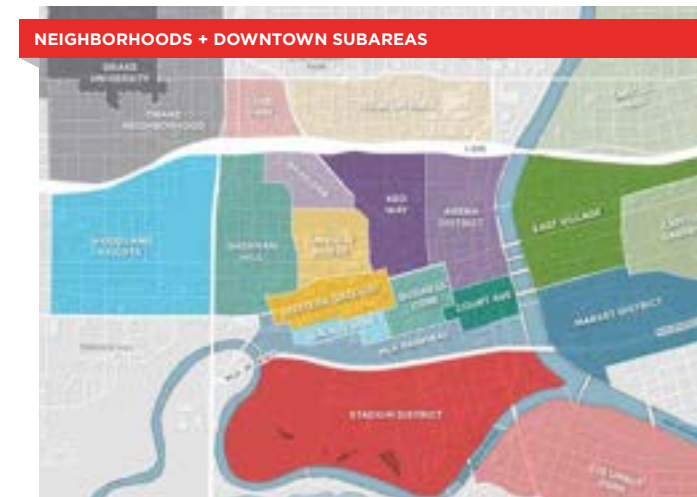

Neighborhood map, Downtown DSM: Future Forward Plan 2022.



The Green Ring design proposal, Downtown DSM: Future Forward Plan 2022.

PLAN FRAMEWORK

Year of Plan: 2022

VISION

- Destination
- Inclusive
- Opportunities
- Welcome Surprises

LENSES

- Inclusivity
- Sustainability
- Vibrancy
- Wellness
- Choice

GOALS

- Welcoming Urban Neighborhood Arts and Entertainment
- Rewarding Market for Development
- Vibrant Outdoor City
- Connected and Sustainable Mobility

IMPLEMENTATION

The plan laid out six initiatives. Each was given a specific vision, key elements, and strategies for how the project initiatives will advance the plan Goals.

FUTURE 6

- Green Ring
- Skywalks Reimagined
- Inner Circle
- Stadium District
- Connected Corridors
- Stronger Neighborhoods

PARTNERSHIPS + INCENTIVES

Greater Des Moines Partnership is the economic and community development organization that serves Greater Des Moines (DSM), Iowa. The Partnership includes 6,500 Regional Business Members, 400 Investors, and 24 Affiliate Chambers. It drives economic growth for the region through a unified voice.

FINANCIAL INCENTIVES: Grants, Loans, Revolving Loans, Site Development Subsidizing Acquisition, Loan Guarantees, Loan Pooling, and Government Equity Financing.

TAX POLICIES: Self Supporting Municipal Improvement District (SSMID), Urban Revitalization Districts, Tax Abatement, Property Tax Abatement, Property Tax Exemptions, Tax Increment Financing (TIF), and Tax Credits.

OTHER ASSISTANCE: Land Banking, Enterprise Zones, Des Moines Action Loan Fund, Microloan Program, Loan Injection Program, and Revolving Loan Fund.

Sources

Historic Maps:

Mills, R., Salmon, G. & Tanner, H. S. (1825). Greenville District, South Carolina. [Baltimore: F. Lucas, Jr. for Mill's atlas] [Map] Retrieved from the Library of Congress, <https://www.loc.gov/item/2013593133/>.

Ruger, A. (1871) Birds eye view of the city of Chattanooga, Hamilton County, Tennessee. [St. Louis] [Map] Retrieved from the Library of Congress, <https://www.loc.gov/item/73694525/>.

Snedden, R. K. (1863) Map of Richmond, Virginia. [to 1865] [Map] Retrieved from the Library of Congress, <https://www.loc.gov/item/gvhs01.vhs00051/>.

Demographics:

US Census Bureau. <https://www.census.gov/quickfacts/fact/table/>

Master Plans and Reports:

Birmingham City Center Master Plan. Adopted March 4, 2020. <https://www.downtownbhamplan.com/>

Birmingham's City Center Business Improvement District (BID) 2022 Annual Report. <https://downtownbhm.com/about/>

Downtown DSM Future Forward. December 1, 2022. <https://www.dsmpartnership.com/downtowndsmusa/about-downtown/downtown-vision-plan-action-plan>

Downtown Plan: The Next Ten Years, Raleigh, NC. September 15, 2015. <https://issuu.com/downtownraleighalliance/docs/downtownplan>

Downtown Reborn. (n.d.). Greenville City Government. Retrieved October 24, 2023, from <https://citygis.greenvillesc.gov/downtownreborn/index.html>

Greater Des Moines Partnership Downtown DSM Quarterly Report. September 2023. <https://www.dsmpartnership.com/downtowndsmusa/filesimages/PDFs/Downtown%20Q3%20Board%20Report.pdf>

Richmond 300 A Guide for Growth: Designing an equitable, sustainable, and beautiful Richmond for its 300th birthday in 2037, September 29, 2020. <https://www.rva.gov/economic-development/richmond-300>

State of Downtown Raleigh, Downtown Raleigh Alliance. 2023. <https://downtownraleigh.org/sod-2023>

Skyline Images:

Birmingham Skyline Creator: Sean Pavone

Copyright: Sean Pavone 2012 All Rights Reserved

Additional Resources:

About Us | Richmond. (n.d.). Retrieved November 6, 2023, from <https://www.rva.gov/economic-development/about-us>

Charleston Downtown Plan. (n.d.). Urban Strategies. Retrieved November 6, 2023, from <https://www.urbanstrategies.com/project/downtown-plan/>

Chattanooga Housing Action Plan for affordable housing—NOOGAtoday. (n.d.). Retrieved November 6, 2023, from <https://noogatoday.6amcity.com/city/chattanooga-housing-action-plan>

Cooksey, J. (2009, September 30). Realizing the Vision. Richmondmagazine.Com. <https://richmondmagazine.com/api/content/be602596-332b-30ca-0fd8-c3b375a7a5a0/>

Downtown Oklahoma City Skyline. (n.d.). Retrieved November 6, 2023, from <https://www.visitokc.com/media-gallery/item/downtown-oklahoma-city-skyline/5e84eff0f3c13944e2fdd8a4/>

Greenville District, South Carolina. (n.d.). [Image]. Library of Congress, Washington, D.C. 20540 USA. Retrieved November 6, 2023, from <https://www.loc.gov/item/2013593133/>

Historic District Commission | City of Little Rock. (n.d.). Retrieved November 6, 2023, from <https://www.littlerock.gov/business/planning-and-development/divisions/cultural-heritage-historic-preservation/>

How a City Under 200,000 People Is Outperforming Most Startup Hubs | Inc.com. (n.d.). Retrieved November 6, 2023, from <https://www.inc.com/jeff-barrett/how-chattanooga-attracted-gary-vaynerchuk-steve-case-2-billion-in-startup-exits.html>

How Chattanooga Created \$1.8B In Startup Exits In Under 5 Years | Inc.com. (n.d.). Retrieved November 6, 2023, from <https://www.inc.com/peter-cohan/how-chattanooga-created-18b-in-startup-exits-in-under-5-years.html>

Little Rock Convention & Visitors Bureau Releases 2022 Annual Report. (n.d.). Little Rock, AR. Retrieved November 6, 2023, from <https://www.littlerock.com/media/press-releases/little-rock-convention-visitors-bureau-releases-2022-annual-report/>

Map of Richmond Virginia. A.D. 1863. (n.d.). Encyclopedia Virginia. Retrieved November 6, 2023, from <https://encyclopediaivirginia.org/438hpr-5b48fb3b9187a95/>

River City Company. (n.d.). River City Company. Retrieved November 6, 2023, from <https://www.rivercitycompany.com>

The Creative Corridor: A Main Street Revitalization for Little Rock | 2014 ASLA Professional Awards. (n.d.). Retrieved November 6, 2023, from <https://www.asla.org/2014awards/199.html>

In accordance with scope of services for Phase 4, Walker project representatives will assist Sasaki Design with the research of parking and curb management ordinances, policies, and practices to comprehensively understand and document all factors related to parking and curb management in Downtown Little Rock. Recent project team discussions continue to center around recognizing the general oversupply of parking in downtown while focusing on opportunities for more efficient parking use. Such discussion narratives have shifted toward an understanding of how parking benefit districts could support redevelopment initiatives in each of the study area subdistricts.

Summary of Conclusions

Existing Conditions

- A Parking Benefit District in the Convention Center District could allow the City of Little Rock to progress toward a livelier district and a more balanced parking system.
- Approximately **1,700 parking spaces remain vacant** on a typical day within the district (62% occupied)
- The district is unbalanced, with office-dominated experiencing very little activity in evening and weekend hours.

Redevelopment Opportunities

- The redevelopment of eight (8) surface parking lots can increase density and activity in the district to help progress toward a 24-hour district.
- Assuming the addition of the proposed 650-space parking structure, the existing parking supply could potentially support redevelopment activities suggesting a potential mix of **250 new residential units, 80,000 SF retail/food and beverage, and 25,000 SF of evening entertainment.**
- This suggested redevelopment scenario would add approximately 1,550 spaces of peak demand within the district (excluding event demand).

How Does a Parking Benefit District Work?

A parking benefit district typically operates through a system of parking meters, parking permits, or other parking access-controlled areas which administer parking fines for non-compliance. The revenue generated from these sources is typically collected and managed by a local authority or organization designed to oversee the parking assets in the district. The funds collected from parking fees and fines are then reinvested back into the district after parking asset operating and capital costs have been settled. The specific allocation of funds can vary depending on the needs and priorities of the district. However, the primary goal is to use the revenue to improve parking and transportation options within the district. In the case of Downtown Little Rock, a primary goal would most likely focus on consolidating parking inventory for shared public use.

Some common uses of the parking benefit district funds include:

1. **Parking infrastructure improvement:** The funds can be used to build or expand parking facilities, such as parking structures or lots, to accommodate the parking demand for the district.
2. **Transportation improvements:** The funds can be used to enhance public transportation options, such as improving bus or transit services, implementing bike lanes, or supporting ride-sharing programs.
3. **Alternative transportation incentives:** The funds can be used to promote and incentivize the use of alternate transportation modes, such as offering subsidies for public transportation passes, providing bike-sharing programs, or implementing ride-sharing incentives.
4. **Maintenance and enforcement:** The funds can be used to cover the costs of maintaining parking facilities, enforcing parking regulations, and managing the overall parking system in the district.

Specific projects and initiatives funded by a parking benefit district are typically determined through a collaborative process involving local stakeholders, community input, and the designated authority or organization responsible for managing the district.

Overall, the purpose of a parking benefit district should be to manage parking demand, improve transportation options, and enhance the overall livability and economic vitality of the area. By reinvesting the revenue generated from parking back into the district, it helps create a more sustainable and efficient parking and transportation system.

Convention Center District Case Study

Project team representatives defined one potential parking benefit district shown in the following exhibit with the boundaries defined with the use of dashed red lines. The lines outline an area bound by Broadway Street to the west, West 3rd Street to the south, Cumberland Street to the east and LaHarpe Boulevard to the north. Comprised of 18± city blocks, this area represents nearly twenty-five percent of the larger study area in downtown identified under the district headings of the Financial Quarter, the River Market District, and the MacArther Park Historic District. This larger study area is commonly bound by Broadway Street to the west, Interstate 630 to the south, Interstate 30 to the east, and the Arkansas River to the north. For the purpose of this case study, we're referring to this downtown sub-district as the Convention Center District.

Exhibit 01: Convention Center District – Proposed Parking Benefit District



Source: Sasaki Design and Walker Consultants, 2024

Estimated Land Use Quantities

Within this sub-district, a high-level data capture estimates the following land use groupings:

- 40,000-sf of commercial retail space, to include a mix of food service and merchandise, primarily located at street level
- 800,000-sf of commercial and professional office space, to include County and Federal court systems
- 800± hotel rooms, to include the Little Rock Marriott, the Capital Hotel, and the Double Tree by Hilton Little Rock
- 180± residential units
- 220,000-sf Statehouse Convention Center
- 2,600 seat Robinson Center
- 60,000-sf eStem Public Charter School
- Old Statehouse Museum
- Historic Arkansas Museum

While a portion of the commercial retail and convention center land use quantities listed above may experience captive use from the three hotels, professional and service line employment centers, other land uses may be considered primary destinations for employees and visitors that do not patronize multiple land use destinations. Other locations, such as the eStem Public Charter School, may have student-based populations which do not require parking inventory beyond the parking needs of teachers and administrators. Typically, visitors to the County and Federal court systems may not be patronizing other commercial retail destinations beyond their immediate business needs.

Existing Parking Inventory

Exhibit 01 has also identified several significant parking collectors within the proposed parking benefit district. In total, there are approximately 2,750 parking spaces across public and private parking. These significant parking collectors have been identified and numbered as follows:

Structured Parking

- 1. Robinson Center parking structure (424 West Markham Street):** This publicly owned structure offers 550 public parking spaces of which nearly 50% are under contract for employee parking (118± spaces) and hotel valet parking (170± spaces) storage. Approximately 262± parking spaces are typically available for visitor parking during peak operating hours and the additional 118± employee parking spaces may be added to the 262± visitor parking spaces for a total of 380± public parking spaces on nights and weekends.
- 2. Statehouse Convention Center parking structure (201 Main Street):** This publicly owned structure offers 650 public parking spaces of which 103% are under contract for downtown employee parking (574± spaces) and hotel valet parking (100± spaces). Since the parking structure is oversold, it's understood that no parking spaces are available for visitor parking during peak operating hours. As a result of this scenario, the approximate 550± parking spaces may only be available for visitor parking space needs on nights and weekends.
- 3. Heritage West parking structure (225 East Markham Street):** This privately owned structure offers 100± public parking spaces for downtown parking use. The structure offers hourly parking rates and credit card only payment is accepted.
- 4. Stephens Building parking structure (entrance at 143 South Louisiana Street):** This privately owned structure provides employee parking needs for the Stephens Building and advertises no public parking available. It is understood that 550± employee parking spaces are available for use of the Stephens Building tenants.
- 5. Beach Abstract and Guaranty Company parking structure (100 Center Street):** This privately owned structure does not advertise public parking availability as it is assumed for use by downtown employees specific to the Beach Abstract and Guaranty Company. It is understood that 100± employee parking spaces are available for use of the Beach Abstract and Guaranty Company tenants.
- 6. Proposed parking structure development site (200 block of South Louisiana Street):** This surface parking area has been identified for the development of an additional 650-space parking structure to support the public parking needs of the Convention Center District.

Surface Parking

Additionally, **Exhibit 01** has identified multiple areas alphabetized and shown by yellow-shaded parcels which currently reflect areas where surface lot parking remains active to support parking demand for adjacent individual land uses.

- A. 138 Scott Street lot – 46± public parking spaces
- B. Capital Hotel surface parking lot (hotel valet and hotel contractor parking only)
- C. 2nd Street and Scott Street surface parking lot (Little Rock Marriott valet parking only)
- D. 2nd Street and Main Street surface parking lot – gated and reserved for monthly parking only (105± spaces)
- E. West 3rd and Center Street surface parking lot- 85± reserved contract parking spaces
- F. West 3rd and Center Street surface parking lot- 58± reserved contract parking spaces
- G. West 3rd Street and South Spring Street- 80± surface parking spaces reserved contract parking
- H. West 2nd Street and Center Street- 65± surface parking spaces for hourly public parking use
- I. West 3rd Street and Broadway Street surface parking lot- 50± parking spaces (Pulaski County employee parking only)
- J. West 2nd Street and South Spring Street surface parking- 50± Pulaski County government employee parking and visitor parking spaces

Exhibit 02 illustrates the parking supply by City block within the Convention Center District boundaries.

Exhibit 02: Convention Center District – Parking Supply by City Block



Source: Google Earth and Walker Consultants, 2024

Existing Parking Demand

While true specific parking utilization is unknown, a general parking demand was estimated through on-site observations and a survey of historical aerial imagery for surface lots. There was no access available for two of the private parking structures, Stephens Building (4) and Beach Abstract and Guaranty Company (5), as public access for these structures is generally restricted and limited to tenants of the adjacent office space during the weekday business hours. It's understood that these parking structure assets would continue to support the commercial office needs of the adjacent office space and thereby are assumed to be "full" and were extracted from the analysis. Parking structure elevators and stair towers provide direct access to building lobbies of the adjacent commercial office space, which would require public access to the building office lobbies to gain access to the parking structure inventory. The remaining parking structures were observed to be approximately 50% full at the daytime peak. **Exhibit 03** outlines the approximate supply and demand for each facility.

Exhibit 03: Convention Center District – Approximate Facility Supply and Demand

Parking Facilities	Approx. Supply	Approx. Demand*	Adequacy
Parking Structures	1,950	650	1,300
1. Robinson Center	550	275	275
2. Statehouse Convention Center	650	325	325
3. Heritage West	100	50	50
6. Proposed Garage	650	0	650
Surface Parking	799	402	397
A. 138 Scott Street surface parking lot	46	27	19
B. Capital Hotel surface parking lot	125	50	75
C. 2 nd Street and Scott Street surface parking lot	135	70	65
D. 2 nd Street and Main Street surface parking lot	105	60	45
E. West 3 rd Street and Center Street surface parking lot	85	36	49
F. West 3 rd Street and Center Street surface parking lot	58	20	38
G. West 3 rd Street and South Spring Street surface parking lot	80	34	46
H. West 2 nd Street and Center Street surface parking lot	65	25	40
I. West 3 rd Street and Broadway Street surface parking lot	50	30	20
J. West 2 nd Street and South Spring Street surface parking lot	50	50	0
Total	2,749	1,052	1,697

Source: Walker Consultants, 2024

Each city block has various land uses that vary in parking needs throughout the day. A block with exclusively office uses would peak during daytime hours during the weekday, while an exclusively residential block may have diminished demand during the daytime but peak overnight or on the weekend. Exhibit 04 highlights the “flow” of parking behavior throughout the Convention Center District from weekday daytime to weekday evening, to weekend scenarios. High, moderate, and low relative demand is denoted by red, yellow, and green, respectively. Note that most of the district has demand during the weekday daytime hours but loses significant activity in the evening and weekend times.

Exhibit 04: Convention Center District – Parking Demand Flows



Source: Walker Consultants, 2024

Redevelopment Opportunities

Several existing surface parking sites can be redeveloped into higher and better uses that support the growth of the district. The overarching goal of redevelopment is to increase the vibrancy within the district during non-working hours, creating a true 24-hour district. The existing district is overwhelmingly office and event land uses, with minimal supporting commercial and residential uses. The redevelopment scenarios presented should be refined based on a market analysis conducted by a real estate consultant.

Two primary goals to make progress toward increased vibrancy within the district include:

1. Extend the existing mixed-use retail strip (along President Clinton Ave east of S Cumberland St.) into the district, including retail, food and beverage, and residential uses.
2. Redevelop the “office district” subarea to encourage office employees to linger within the district in the evening hours. This could include a variety of retail, food and beverage, or entertainment uses.

Exhibit 05 highlights the prime redevelopment parcels within the district, designated by different zones to highlight land use groups. It is assumed that all structured parking will remain, along with Pulaski County government surface lots (I) and (J), which have been developed for the county’s specific needs to provide parking for employees and visitors to the adjacent county buildings. These locations could be available on nights and weekends should commercial redevelopment occur in the three privately owned surface lots (E, F, G, and H) which currently provide weekday contract parking options for employees in the district. Removal of the remaining eight (8) surface parking lots (A, B, C, D, E, F, G, and H) would displace as many as 320± existing parking spaces.

Exhibit 05: Convention Center District – Potential Redevelopment Sites



Source: Walker Consultants, 2024

Redevelopment Scenario

The prime redevelopment parcels in Exhibit 05 can be categorized into two zones to align with the redevelopment goals: 1) The Mixed-Use Extension (A, B, C, D) and 2) Office Support (E, F, G, H). These zones are not meant to be distinctly separate but can mesh to form a cohesive downtown.

An illustrative redevelopment example can provide an outline of how additional land uses that generate parking demand can be satisfied with the existing (and proposed) parking within the parking benefit district.

- 1) Mixed-Use Extension
 - 250 additional residential dwelling units
 - 40,000 SF of retail/food and beverage uses
 - 5,000 SF of evening entertainment uses
- 2) Office Support
 - 40,000 SF of retail/food and beverage uses

Exhibit 06 illustrates the high-level parking needs assessment associated with the redevelopment scenario outlined, leveraging industry-supported parking ratios and shared parking principles.

Exhibit 06: Convention Center District – Redevelopment Scenario Parking Needs

District/Zone	Current Parking*			Redevelopment Parking				Net Parking Need
	Supply ¹	Demand ²	Adequacy ³	Displaced Demand ⁴	New Demand ⁵	Removed Supply ⁶	Shared Parking Impact ⁷	
Mixed-Use Extension (A, B, C, D)	1,711	857	854	207	638	411	(191)	+1,064
Office Support (E, F, G, H)	838	665	173	115	200	288	(100)	+503
Total	2,549	1,702	1,047	322	838	699	(291)	+1,567

* Includes all parking facilities within the district that have redevelopment sites (See Exhibit 05)

1 Total supply for all parking facilities within the districts housing the proposed redevelopment sites

2 Total demand for all parking facilities within the district housing the proposed redevelopment sites

3 The estimated availability of parking within the associated grouping

4 Total demand within the surface lots that are proposed for redevelopment

5 Additional demand associated with development program added to the site

6 Existing parking supply within the surface lots proposed for redevelopment

7 Estimated reduction in parking demand associated with the new development program due to shared parking among complementary uses

Source: Walker Consultants, 2024

While further investigation is needed to validate general assumptions, the example in **Exhibit 06** represents a viable solution for the City of Little Rock to redevelop surface parking to higher and better uses while maintaining a sufficient parking supply. As expressed in **Exhibit 03**, the current estimate for parking adequacy is 1,697± spaces, while the additional redevelopment is estimated to generate 1,567± spaces of demand, a peak district occupancy of 92%.

Additional Considerations

There are several assumptions interwoven into the Convention Center District Case Study, resulting in a need for further evaluation. Some additional considerations include:

- Sites B and C are currently used as separate valet storage facilities for the local hotels. These agreements would need to be amended to allow the lots to be redeveloped. This may pose challenges as attempting to share hotel parking inventory, which has been committed to the irregular activity levels of a hotel, would make the availability of the inventory difficult to promote or manage from one week to the next, thus not being an attractive option for hotel management. One option to support the benefit district's needs, would suggest building a valet storage parking structure at the Capital Hotel surface parking lot (B), whereby the two hotels could share in the cost to construct and maintain such a facility.

- Similar to other downtown residential developments, residential developers would most likely need to incorporate on-site parking for residents within their residential site development plans. Suggesting the use of off-site parking to park residents is often a deal breaker for many lenders and developers since residential parking is often provided on-site as an amenity to residents.
- The analysis assumes that events at the convention center or theater can be accommodated at evening and weekend special event times, either through parking management or additional parking provided outside of the benefit district. Patrons may likely be amenable to longer walking distances from parking to their event destination when the addition of retail and food service is offered along the route between the two locations. It has also been noted that weekday convention center patrons may have their parking needs accommodated through the use of valet parking storage facilities while taking advantage of overnight lodging at the downtown hotels.

LITTLE ROCK DOWNTOWN PLAN

Benchmark Cities – New Development and Renovations

2023-09-28



NEW DEVELOPMENT AND RENOVATIONS | BENCHMARKING

DOWNTOWN DEVELOPMENT – TOTAL SF OF RENTABLE BUILDING AREA (RBA)

New Development (2010-2023 YTD)				
	Little Rock	Chattanooga	Greenville	Richmond
Office	253,800	165,900	947,000	2,108,900
Hotel	450,000	324,900	1,145,800	625,100
Multifamily Rental	313,000	1,144,200	2,490,700	8,623,300
Retail	49,500	114,900	309,500	124,900
Total	1,066,300	1,749,900	4,893,000	11,482,200
Renovations (2010-2023 YTD)				
	Little Rock	Chattanooga	Greenville	Richmond
Office	421,200	474,500	804,900	1,935,100
Hotel	1,091,800	226,000	189,000	1,220,100
Multifamily Rental	249,200	50,500	185,000	1,432,700
Retail	52,700	85,900	116,200	173,800
Total	1,814,900	836,900	1,295,100	4,761,700

Source: Esri, CoStar, Sasaki, SB Friedman
No for-sale product is included in this analysis.

SB Friedman Development Advisors, LLC

KEY DEMOGRAPHIC INFORMATION

NEW DEVELOPMENT AND RENOVATIONS | BENCHMARKING

DOWNTOWN DEVELOPMENT – SF, UNITS, ROOMS

New Development (2010-2023 YTD)				
	Little Rock	Chattanooga	Greenville	Richmond
Office	253,800 SF	165,900 SF	947,000 SF	2,108,900 SF
Hotel	463 rooms	535 rooms	1,558 rooms	627 rooms
Multifamily Rental	245 units	988 units	2,380 units	8,178 units
Retail	49,500 SF	114,900 SF	309,500 SF	124,900 SF
Renovations (2010-2023 YTD)				
	Little Rock	Chattanooga	Greenville	Richmond
Office	421,200 SF	474,500 SF	804,900 SF	1,935,100 SF
Hotel	820 rooms	343 rooms	200 rooms	1,425 rooms
Multifamily Rental	183 units	69 units	197 units	1,423 units
Retail	52,700 SF	85,900 SF	116,200 SF	173,800 SF

Source: Esri, CoStar, Sasaki, SB Friedman
No for-sale product is included in this analysis.

SB Friedman Development Advisors, LLC

DEMOGRAPHIC PROFILES

Downtowns	Land Area (sq. miles)	Population (2023)	Pop. Share of Region ^[1]	Population Growth (%) (2010-2023)	% Pop. Aged 20-34	% Pop. Bachelor's Degree or Higher ^[2]	% BIPOC ^[3]	Median Age	Median Household Income
Little Rock	2.5	4,395	0.6%	+8%	30.4%	56.8%	53.9%	40.2	\$40,572
Chattanooga	0.9	3,745	0.7%	+48%	28.0%	53.5%	28.3%	39.5	\$83,152
Greenville	1.5	7,141	0.7%	+61%	27.2%	61.8%	22.7%	40.1	\$82,979
Richmond	3.5	27,565	2.0%	+69%	49.5%	68.6%	51.4%	24.8	\$50,540

Source: Esri, Sasaki, SB Friedman

[1] The region is defined as the Metropolitan Statistical Area (MSA). For a full list of all geographies comprising each MSA, see the Appendix.

[2] Population age 25 and older

[3] Defined as percentage not White alone

SB Friedman Development Advisors, LLC

NEW DEVELOPMENT AND RENOVATIONS | BENCHMARKING

DRAFT

DOWNTOWN DEVELOPMENT – CAPTURE OF REGION (PER RBA)

New Development (2010-2023 YTD)				
	Little Rock	Chattanooga	Greenville	Richmond
Office	9%	13%	27%	37%
Hotel	25%	20%	45%	32%
Multifamily Rental	2%	10%	11%	28%
Retail	1%	4%	5%	2%
Total	4%	10%	14%	25%
Renovations (2010-2023 YTD)				
	Little Rock	Chattanooga	Greenville	Richmond
Office	54%	46%	43%	40%
Hotel	43%	25%	19%	42%
Multifamily Rental	8%	1%	4%	9%
Retail	3%	5%	4%	13%
Total	23%	10%	13%	19%

Source: Esri, CoStar, Sasaki, SB Friedman
No for-sale product is included in this analysis.

SB Friedman Development Advisors, LLC

5

APPENDIX: MSA GEOGRAPHIES

DRAFT

- **Little Rock-North Little Rock-Conway, AR**
 - Faulkner County
 - Grant County
 - Lonoke County
 - Perry County
 - Pulaski County
 - Saline County
- **Chattanooga, TN-GA MSA**
 - Catoosa County, Georgia
 - Dade County, Georgia
 - Hamilton County, Tennessee
 - Marion County, Tennessee
 - Sequatchie County, Tennessee
 - Walker County, Georgia
- **Richmond, VA MSA**
 - City of Richmond
 - Amelia County
 - Charles City County
 - Chesterfield County
 - Dinwiddie County
 - Goochland County
 - Hanover County
 - Henrico County
 - King William County
 - New Kent County
 - Powhatan County
 - Prince George County
 - Sussex County
- **Greenville – Greenville-Anderson, SC MSA**
 - Greenville County
 - Anderson County
 - Pickens County
 - Laurens County

SB Friedman Development Advisors, LLC

6